



Grand Rapids, Michigan, U.S.A. 49504-5298

USER'S OPERATING AND INSTRUCTION MANUAL

MODEL 777

SLICER

OLIVER PRODUCTS COMPANY
777 BREAD SLICER MANUAL

TABLE OF CONTENTS

	PAGE
LIST OF ILLUSTRATIONS.....	ii
SAFETY STATEMENTS.....	iii
UNCRATING AND INSTALLATION	
Uncrating Slicer (Floor Model).....	1
Remove Slicer From Shipping Platform.....	2
Installing Rubber Foot Plugs.....	3
Installing Optional Casters.....	4
Uncrating Slicer (Bench Model).....	5
Rubber Mount Installation (Bench Model Only).....	5
SPECIFICATIONS.....	6
OPERATION.....	7
MAINTENANCE	
Removing Blade Frames.....	9
Replacing Blade Frames.....	12
Changing Blades.....	13
Tightening Belt.....	16
Replacing Belt.....	17
LUBRICATION.....	18
CLEANING.....	18
BLADE FRAME ADJUSTMENTS	
Slices Vary In Thickness.....	19
Clearance Between Blade Frames.....	20
TROUBLESHOOTING.....	21
ILLUSTRATED PARTS BREAKDOWN	
Recommended Spare Parts List.....	24
Mechanical Parts List.....	26
Electrical (Single Phase Machines).....	30
Electrical (Three Phase Machines).....	32
WARRANTY.....	GEN 040225
WARRANTY PROCEDURE.....	GEN 040226
RETURNED PARTS POLICY.....	GEN 040227

**THIS PAGE WAS INTENTIONALLY
LEFT BLANK.**

LIST OF ILLUSTRATIONS

FIGURE NO.		PAGE
1	Removing Shipping Carton	1
2	Preparing Slicer For Installation	2
3	Rubber Foot Installation	3
4	Caster Installation	4
5	Removing Wooden Pallet From Slicer	5
6	Floor Space Diagram	6
7	Placing Bread Loaf In Slicer	7
8	Operating Motor Starting Knob	8
9	Removing Loaf From Slicer	9
10	Removing Tables and Crumb Chute	10
11	Removing Clip From Eccentric Pin	11
12	Removing Capscrews Securing Blade Frames	12
13	Remove Blade Frame	13
14	Blade Removal Using Knife Tool	14
15	Blade Installation	15
16	Drive Belt Adjustment Nut	16
17	Removing Discharge Table and Crumb Tray	17
18	Removing Connecting Rod	18
19	Adjusting Slice Thickness	19
20	Adjusting Blade Frames Using Eccentric Pins	20
21	Switch Trip Mechanism	22
22	#777 Slicer - Exploded View	25
23	Electrical Components - Single Phase	29
24	Wiring Diagram - Single Phase	30
25	Electrical Components - Three Phase	31
26	Wiring Diagram - Three Phase	32

**THIS PAGE WAS INTENTIONALLY
LEFT BLANK.**

The use of the words WARNING, CAUTION, and NOTE in this manual should be guided by the following:



WARNING

Operating procedures, techniques, etc., which may result in personal injury or loss of life if not carefully followed.



CAUTION

Operating procedures, techniques, etc., which may result in damage to equipment if not carefully followed.

NOTE

An operating procedure, technique, etc., which is considered essential to emphasize.

**THIS PAGE WAS INTENTIONALLY
LEFT BLANK.**

UNCRATING AND INSTALLATION

NOTE

If installing a Bench Model slicer, disregard the following and proceed to page 5, Uncrating A Bench Model Slicer.

UNCRATING SLICER (FLOOR MODEL)

Cut and remove the shipping bands from the slicer carton. Then, using a hammer and a small pry bar, remove the nails attaching the carton to the shipping platform. Two people can then lift the carton up and off the slicer. Remove the (4) hex nuts, washers and bolts which secure the slicer's base to the shipping platform. (Figure 1)

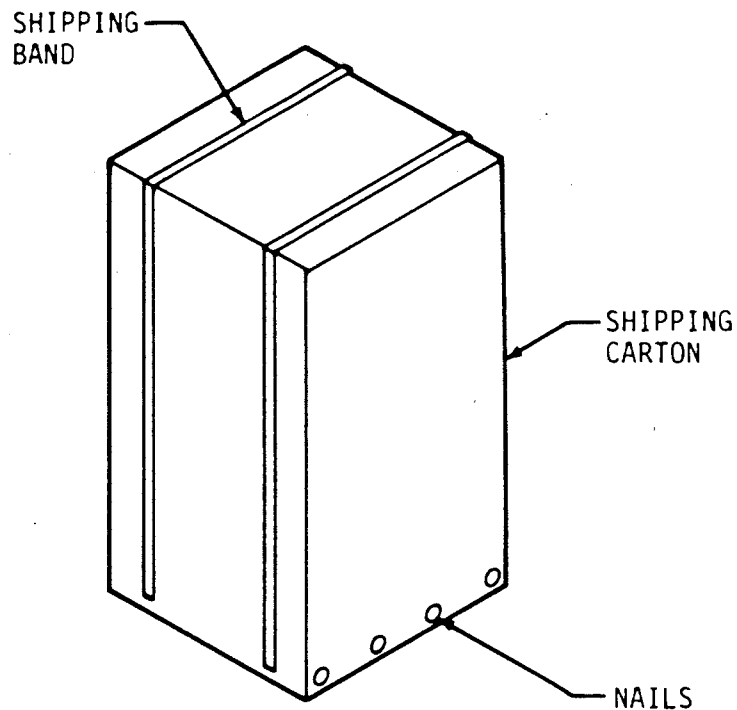

Figure 1. Removing Shipping Carton

REMOVE SLICER FROM SHIPPING PLATFORM

WARNING

Slicer is heavy, use proper technique when lifting. Keep back straight, knees bent, and lift with legs. Use gloves to protect hands.

Lift the slicer off the shipping platform with one person on each side of the slicer. Set the slicer down on a level floor.

Using the shipping platform, or other blocks, carefully lower the slicer to its side as shown in (Figure 2).

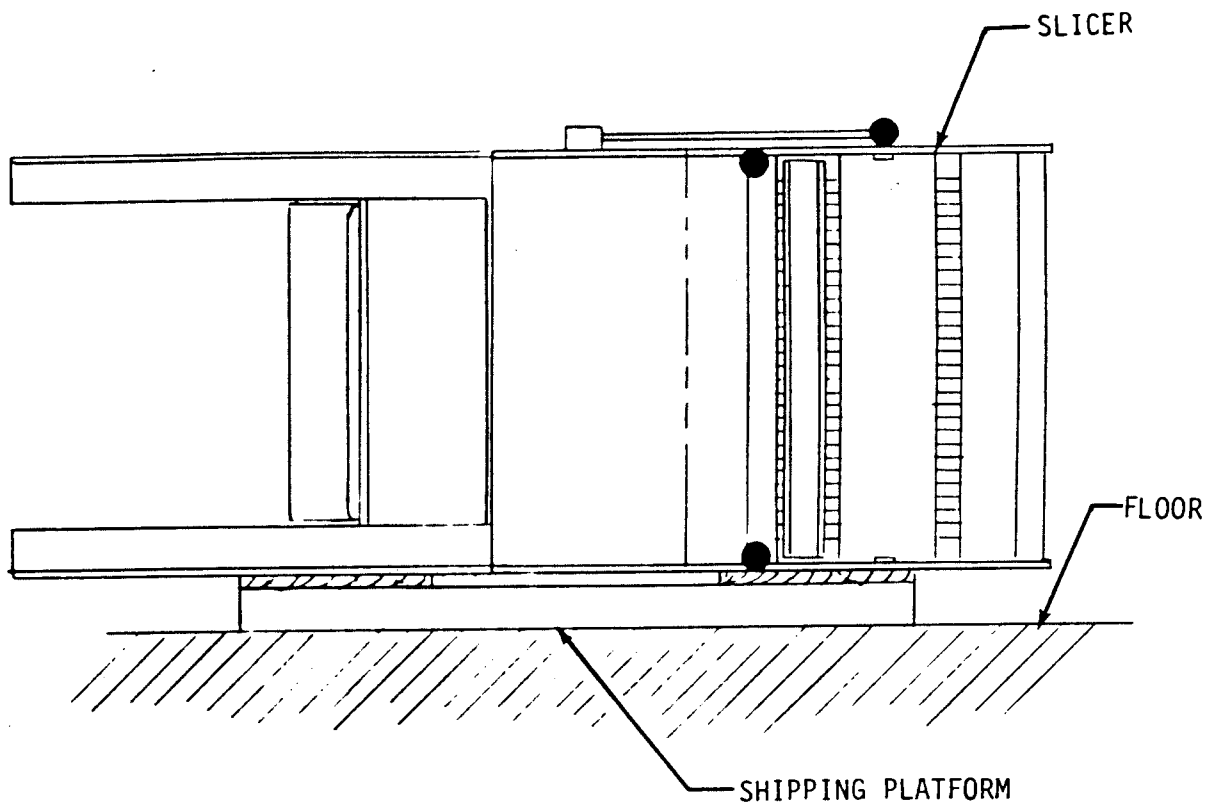

Figure 2. Preparing Slicer For Installation

NOTE

Disregard next step if using caster option with base.

INSTALLING RUBBER FOOT PLUGS

Remove rubber plugs from accessory package and insert plugs into holes in leg bottoms (Figure 3). Carefully restore the machine to the upright position.

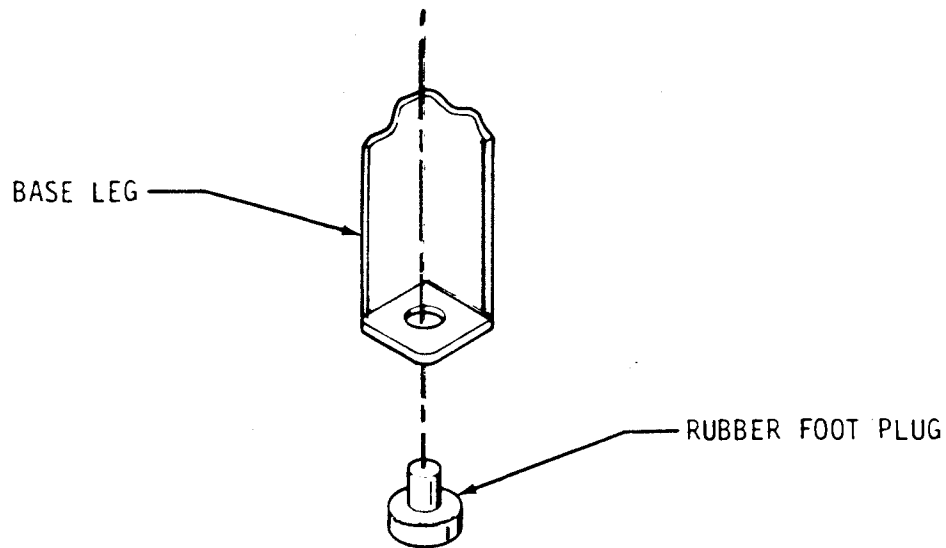

Figure 3. Rubber Foot Installation

INSTALLING OPTIONAL CASTERS

Remove the casters, caster brackets and hardware from the accessory package. Insert the studs of the caster bracket thru the holes provided on the base of your Model 777 slicer. Secure the brackets with the lockwashers and hex nuts. Press fit the casters into the brackets (Figure 4). Carefully restore the machine to the upright position.

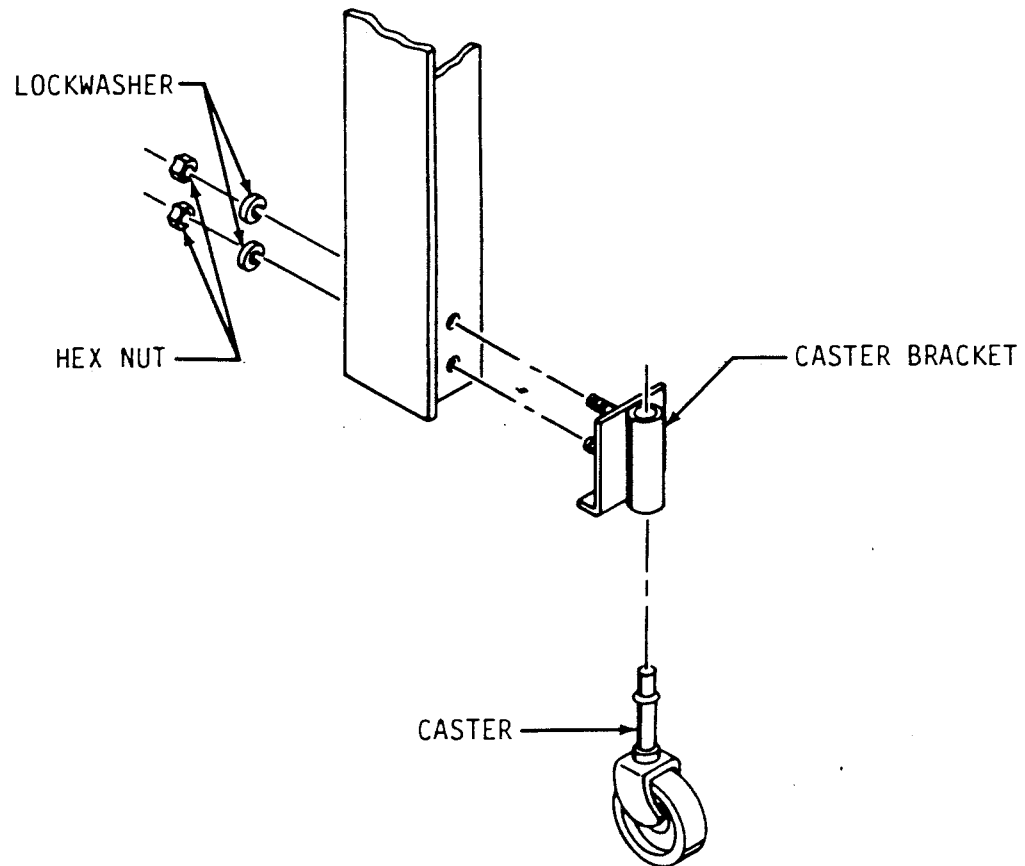

Figure 4. Caster Installation

UNCRATING SLICER (BENCH MODEL)

Remove staples along the bottom of box by prying staples loose with a screwdriver and pulling out staples with pliers. Lift box off the wooden pallet. Gently lay slicer onto its side. (Figure 5)

CAUTION

Place blocks under slicer before removing shipping hooks to prevent slicer from dropping to the floor.

Remove hex nuts and washers from bottom of wooden pallet. Remove shipping hooks and wooden pallet from slicer.

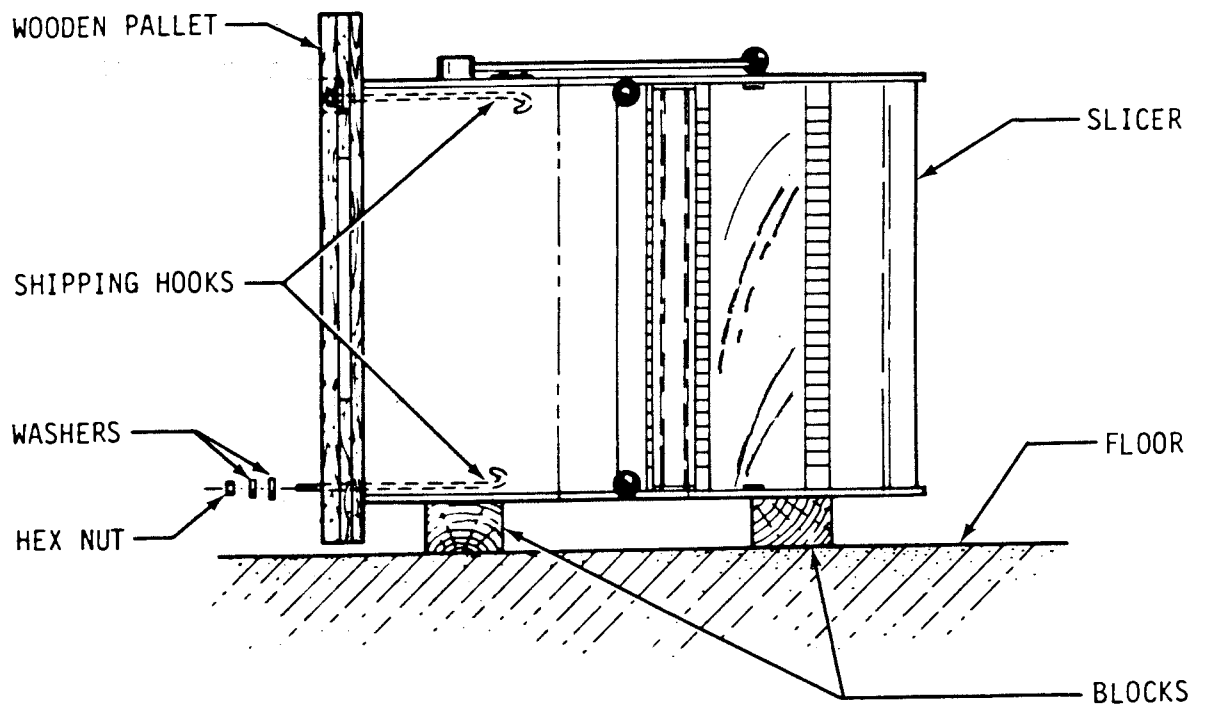

Figure 5. Removing Wooden Pallet From Slicer

RUBBER MOUNT INSTALLATION (BENCH MODEL ONLY)

After removing the wooden pallet, push the (3) pieces of rubber channel from the accessory package over the bottom edges of the slicer frame; one on each side and one on the rear panel.

SPECIFICATIONS

MEASUREMENTS: (Approx.)

Height

Width

Depth

Shipping Weight

FLOOR MODEL

47"

25"

24"

250#

BENCH MODEL

26 1/2"

25"

24"

210#

CAPACITY: (Product)

Up to 16" long, 10 1/2" wide, and from 3 1/2" to 6" high

ELECTRICS:

Standard 1/2 HP, 1-PH 60 CY, 115 VOLT

SLICE SPACING:

Standard 1/2"

APPROVED OPTIONS:

Base (Standard with Floor Model)

Casters

Electrics (1/2 HP, 1 PH 60 CY, 230 VOLT)

Optional Slice Spacings (At Extra Cost) . 1/4, 3/8, 7/16, 9/16, 5/8, 3/4, 1"
Others; Contact Factory

FLOOR SPACE: (Refer to Figure 6)

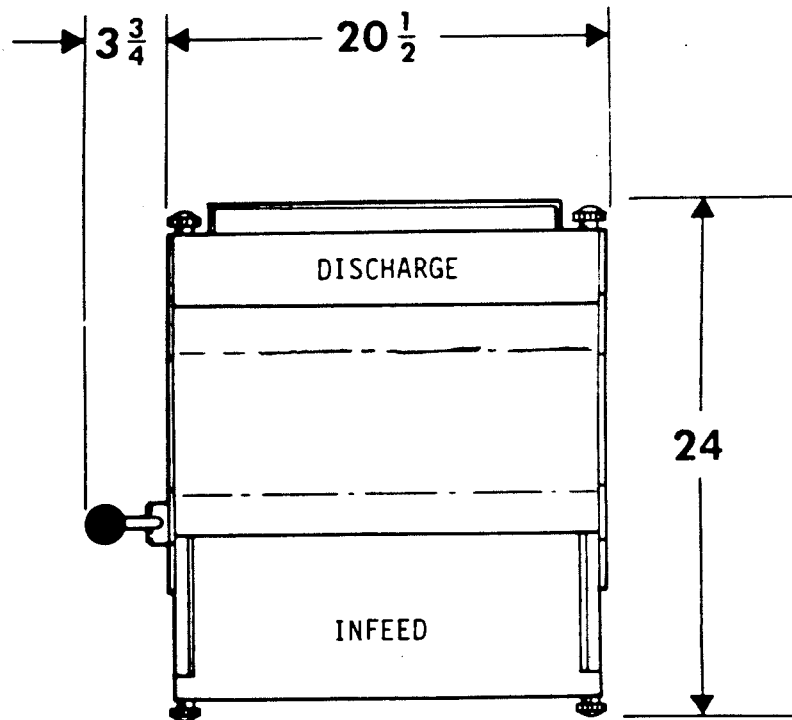

Figure 6. Floor Space Diagram

OPERATION

To operate the slicer, stand on the discharge side, grasp the lever with the right hand, (Figure 7) pull it down as far as it will go and hold. With the left hand, place the loaf of bread in front of the pusher unit. Continue to hold the lever down with the right hand.

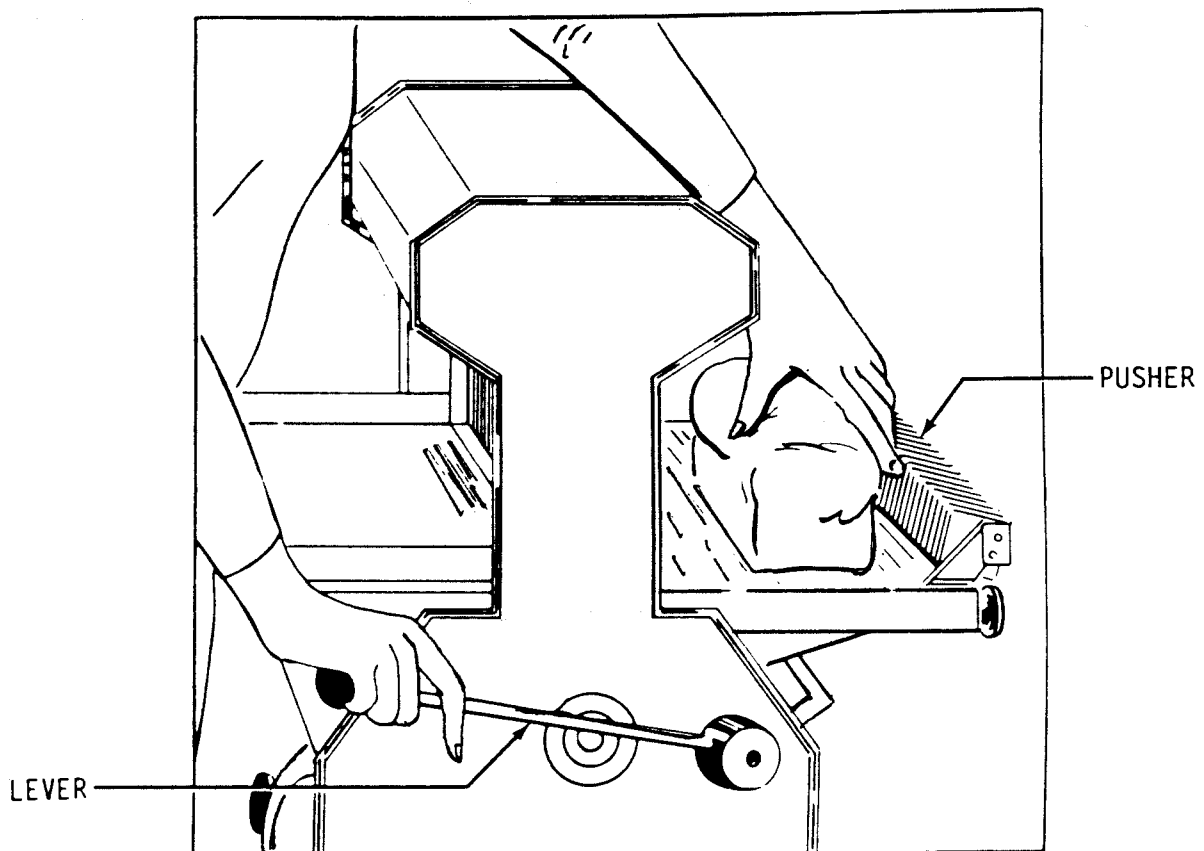

Figure 7. Placing Bread Loaf in Slicer

Now, move the left hand to the discharge side of the machine and pull the motor starting knob. (Figure 8) Allow the right hand to raise slowly with the lever until the loaf contacts the slicer blades. Remove the right hand from the lever allowing the pusher unit to move the loaf through the blades.

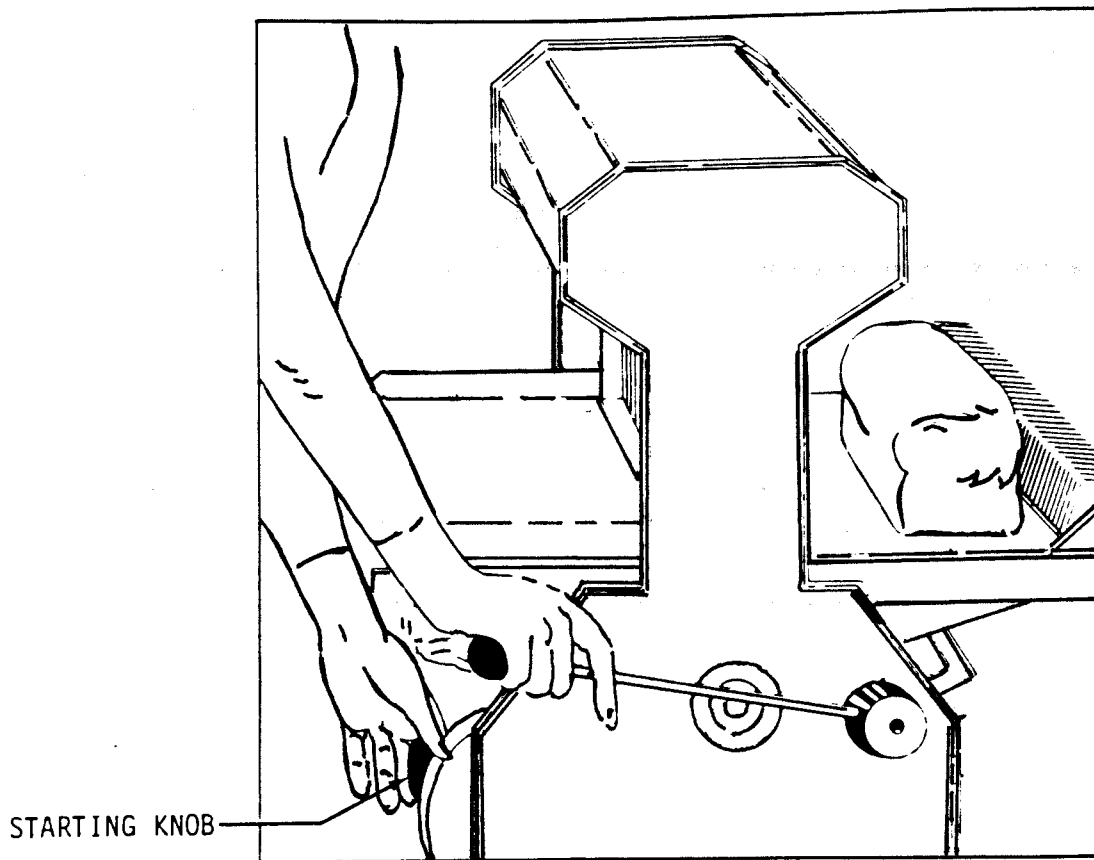

Figure 8. Operating Motor Starting Knob

WARNING

DO NOT TOUCH THE MOVING OR STATIONARY SLICER
BLADES.

The motor and slicer blades will stop automatically the moment the slicing is complete. Remove the loaf from the table and follow the same procedure for each loaf. (Figure 9)

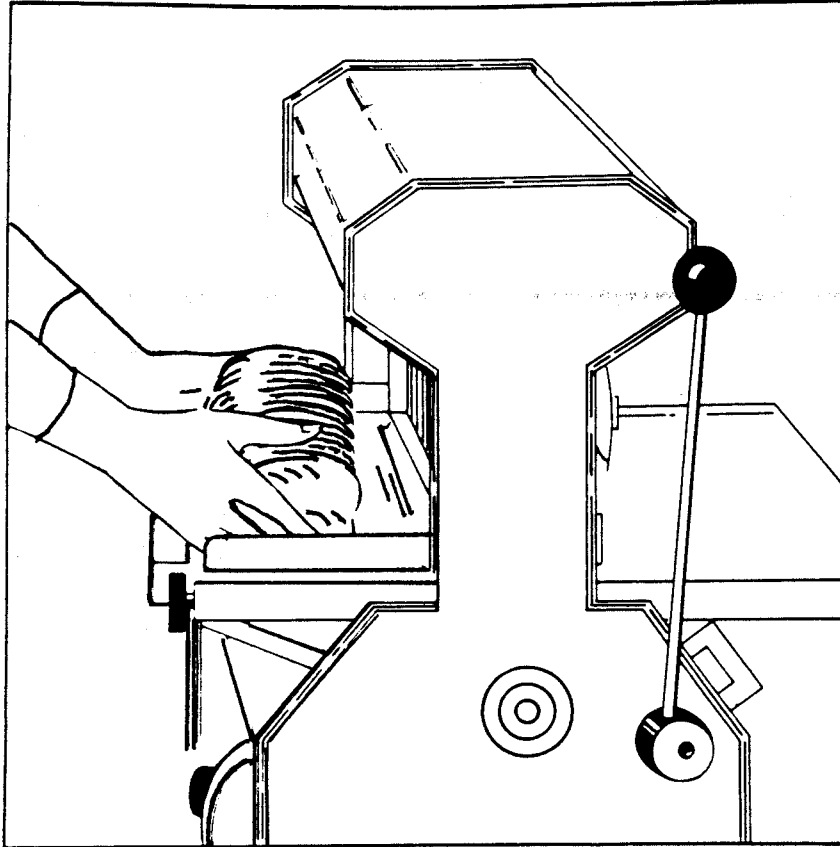

Figure 9. Removing Loaf From Slicer

MAINTENANCE

WARNING

ALWAYS UNPLUG SLICER BEFORE PERFORMING ANY
MAINTENANCE TASK.

REMOVING BLADE FRAMES

Remove infeed table, crumb chute, and discharge table by removing the four black knobs. (Figure 10) Pull clip from eccentric pin. (Figure 11) Slide top

link toward lever side of slicer. Use a wrench to loosen and remove the two capscrews which fasten the blade frame feet to the rocker shaft. (Figure 12)

CAUTION

Do not loosen fixed collar socket setscrew.

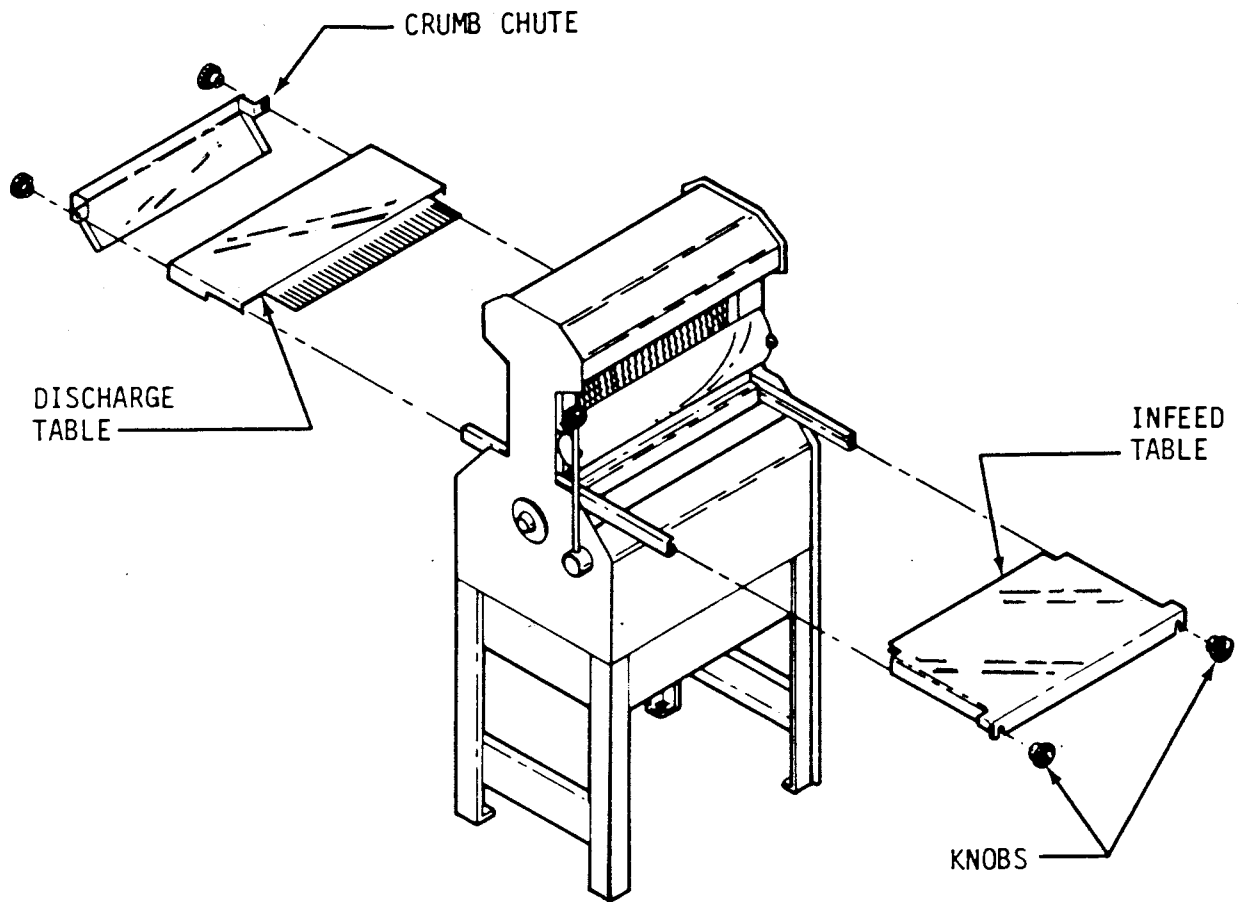

Figure 10. Removing Tables and Crumb Chute

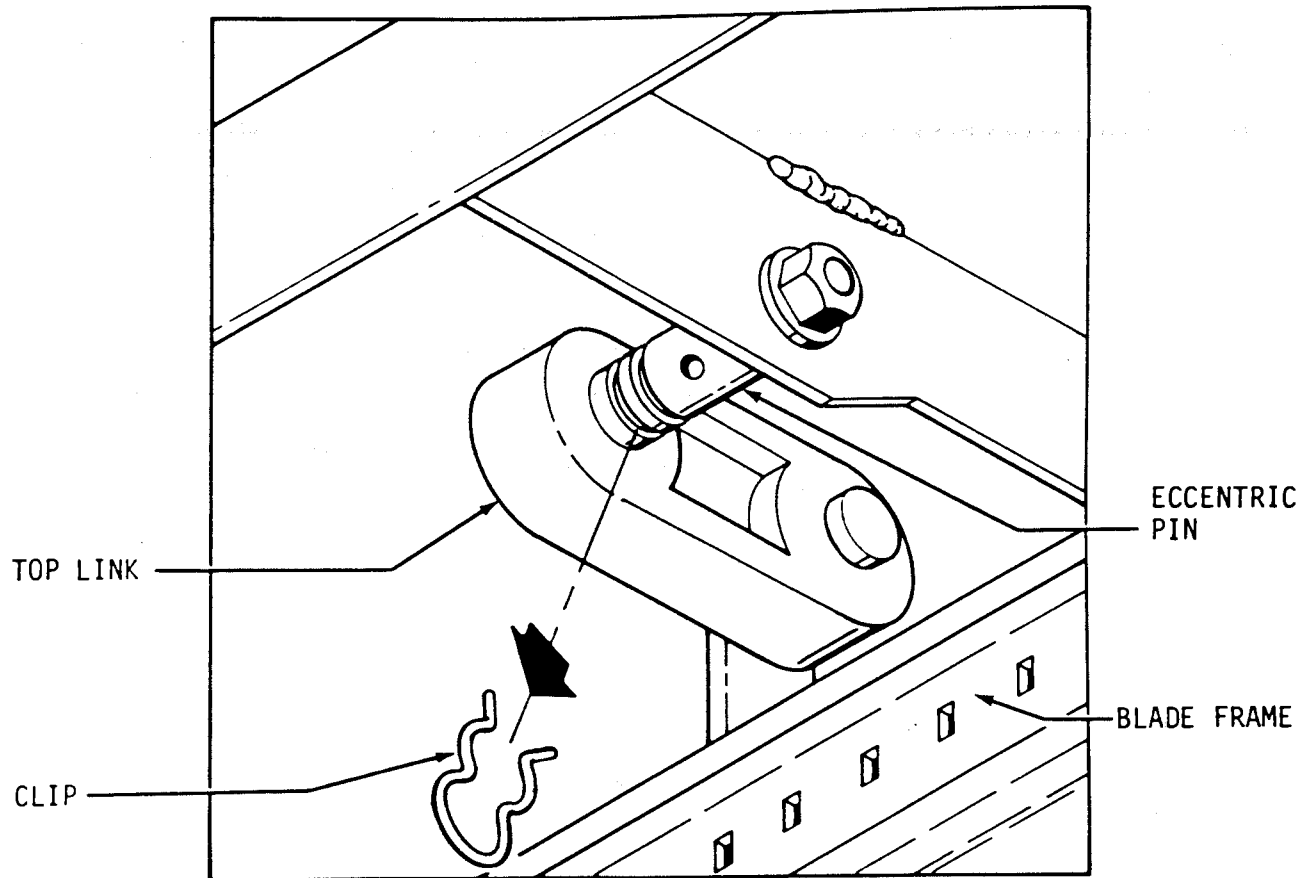

Figure 11. Removing Clip From Eccentric Pin

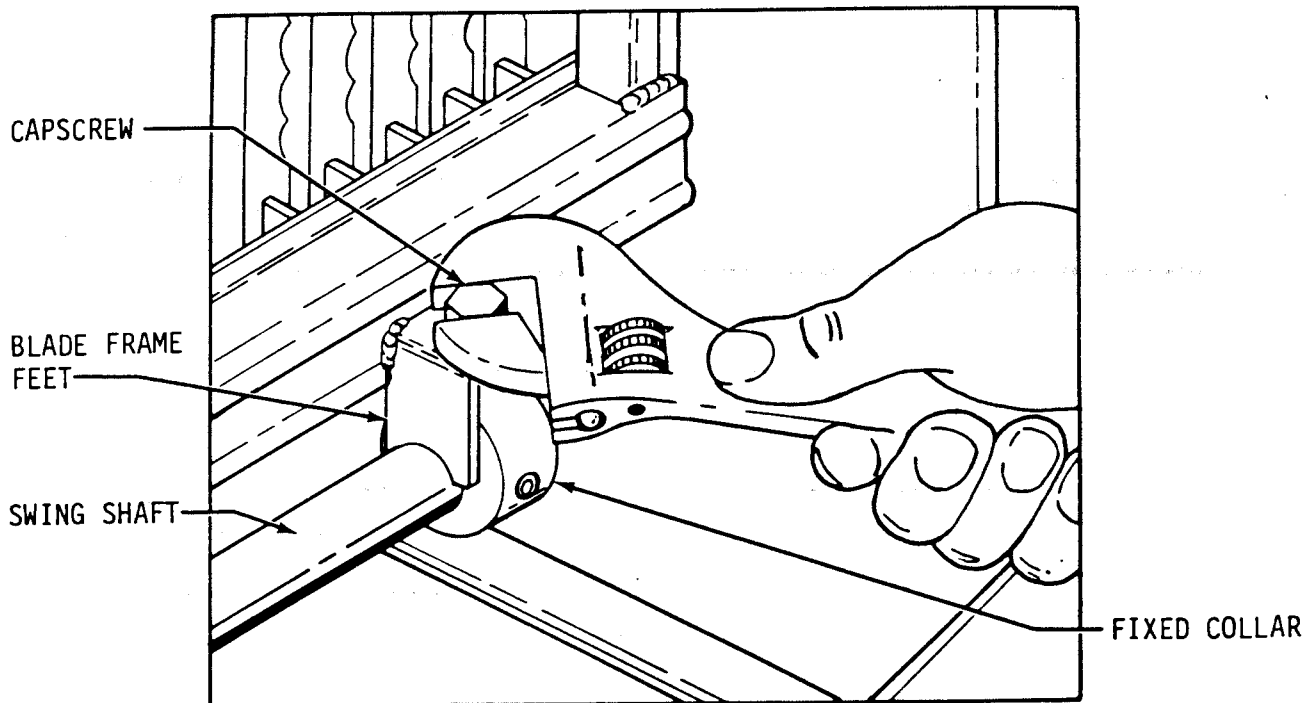

Figure 12. Removing Capscrews Securing Blade Frames

WARNING

BLADES ARE EXTREMELY SHARP. ALWAYS HANDLE BLADE FRAME WITH CARE.

Carefully lift the blade frame from the slicer. (Figure 13) Remove the other blade frame in the same manner.

REPLACING BLADE FRAMES

To replace the blade frames, reverse the removal procedures. Ensure that the feet of the blade frames rest snugly on the swing shafts. Tighten capscrews at feet securely with a wrench. Top links must be attached to the blade frames with clips back in position.

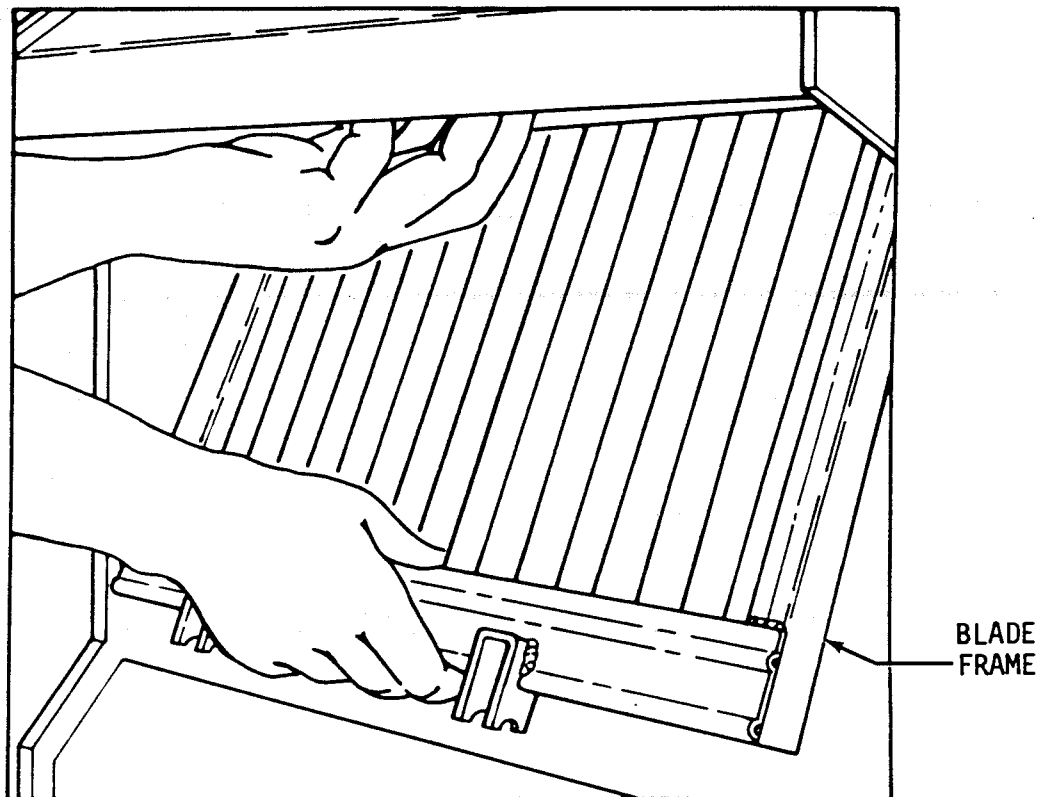

Figure 13. Removing Blade Frame

CHANGING BLADES

WARNING

BLADES ARE EXTREMELY SHARP. ALWAYS HANDLE WITH CARE.

Place blade frame on flat surface. Insert the special knife tool into blade holder. (Figure 14) Lifting up on the knife tool will deflect the upper blade mount reducing tension on the blade. Carefully remove the blade from the blade mount.

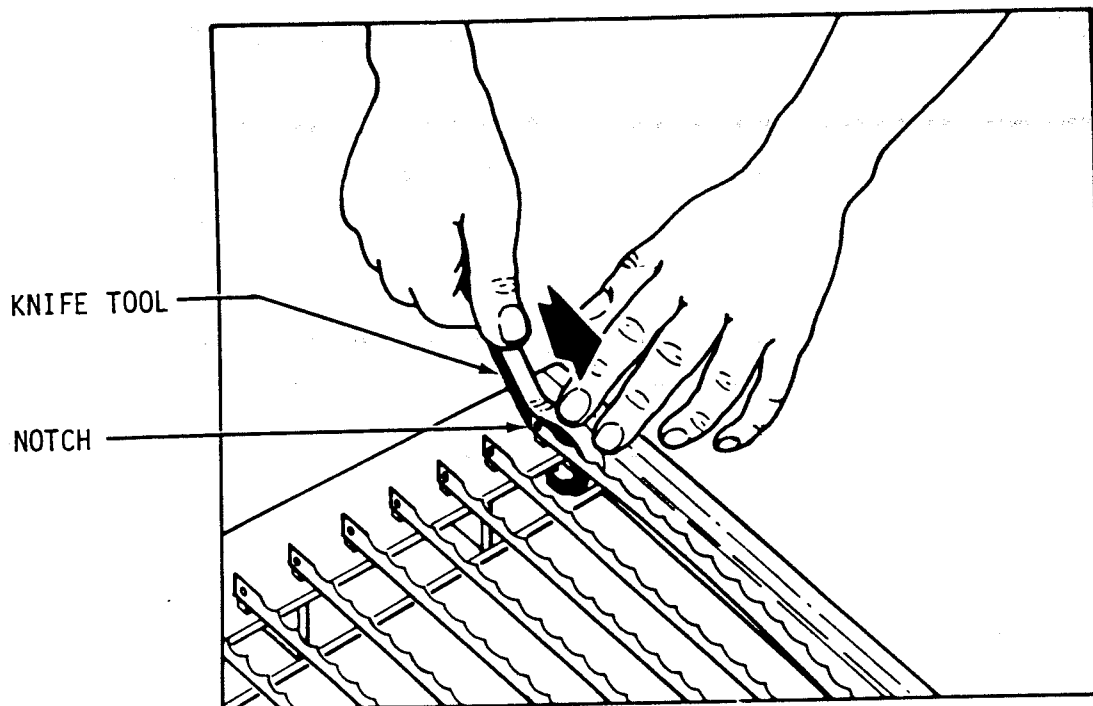

Figure 14. Blade Removal Using Knife Tool

Reverse the procedure to install replacement blade. A paper clip can be used to hold blade in position on lower blade mount during blade installation. (Figure 15)

NOTE

When replacing all the blades, always remove center blades first and work toward the ends. Install the new blades at the ends first and work alternately toward the center.

CAUTION

NEVER put blade frames in slicer without blades.

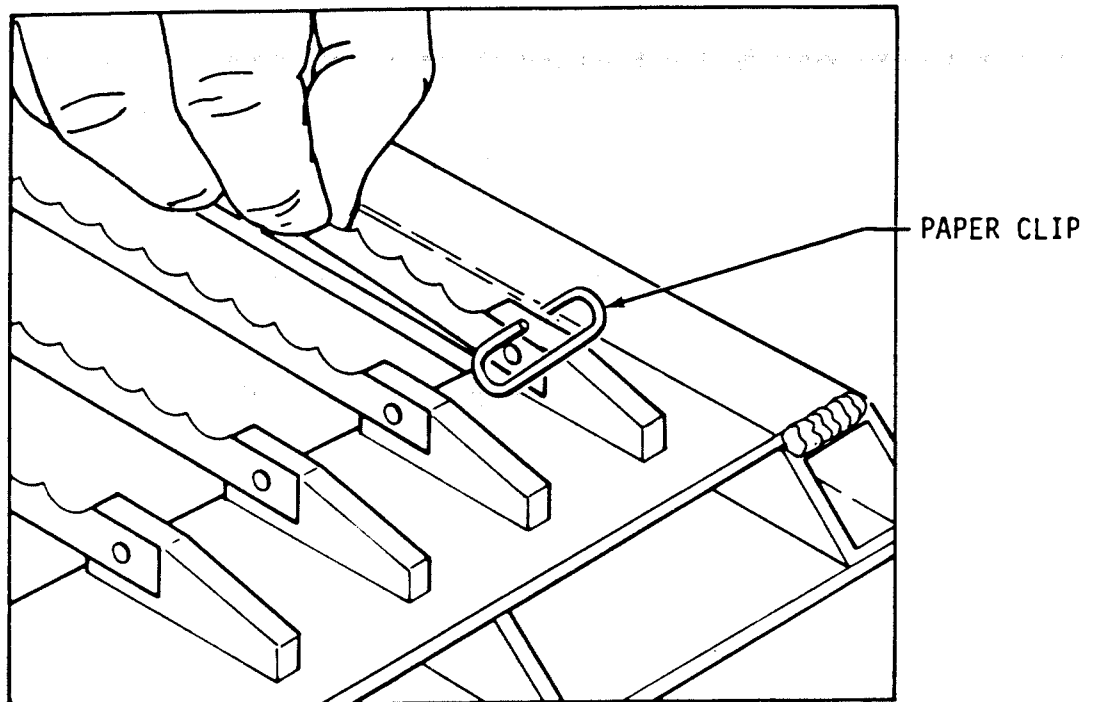

Figure 15. Blade Installation

TIGHTENING BELT

CAUTION

Over-tightening the drive belt may cause bearing or motor failure.

Remove crumb tray from slicer. Locate adjustment nut at lower end of motor mounting plate. (Figure 16) Turn adjustment nut clockwise with a wrench to increase tension on the drive belt. To reduce belt tension, turn adjustment nut counterclockwise. Drive belt should be just tight enough, using moderate finger pressure, to allow a 3/8 inch deflection halfway between the motor drive pulley and the driven pulley.

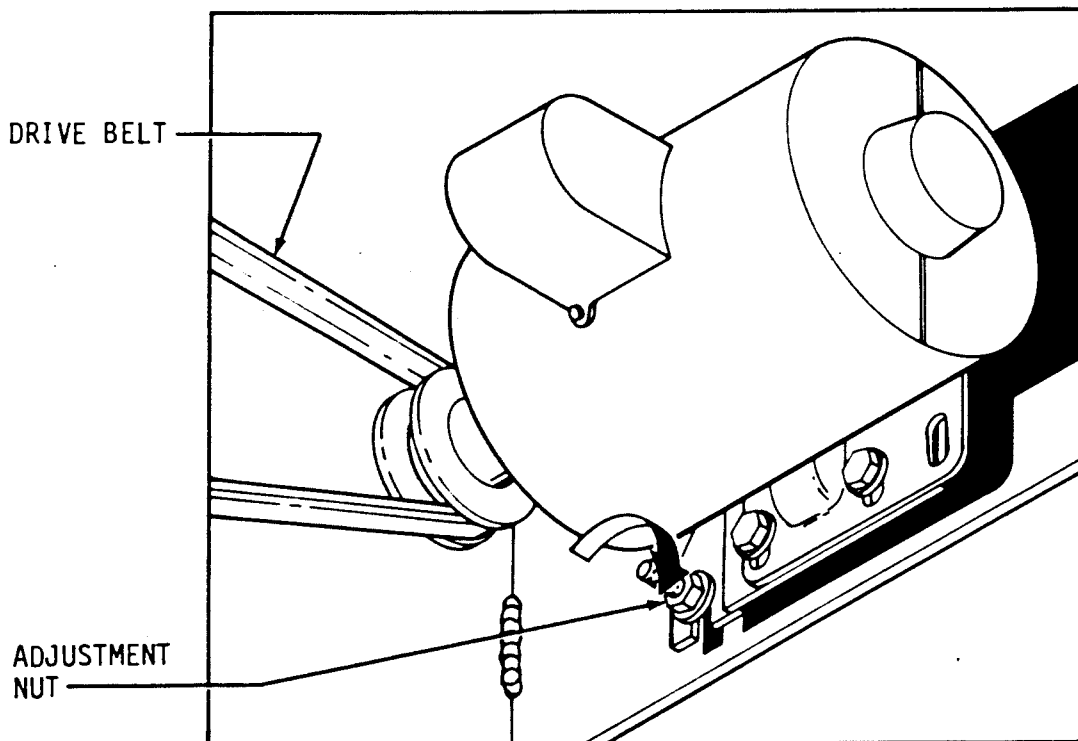

Figure 16. Drive Belt Adjustment Nut

REPLACING BELT

Remove the discharge table and crumb tray from the slicer. (Figure 17) Turn the adjustment nut, at lower end of motor mounting plate, counterclockwise with a wrench to loosen drive belt. Disconnect end of connecting rod at rocker frame by removing two capscrews and cap. (Figure 18) Remove drive belt from pulleys.

Install a new belt by reversing the removal procedure. Refer to Belt Tightening Section to adjust drive belt tension.

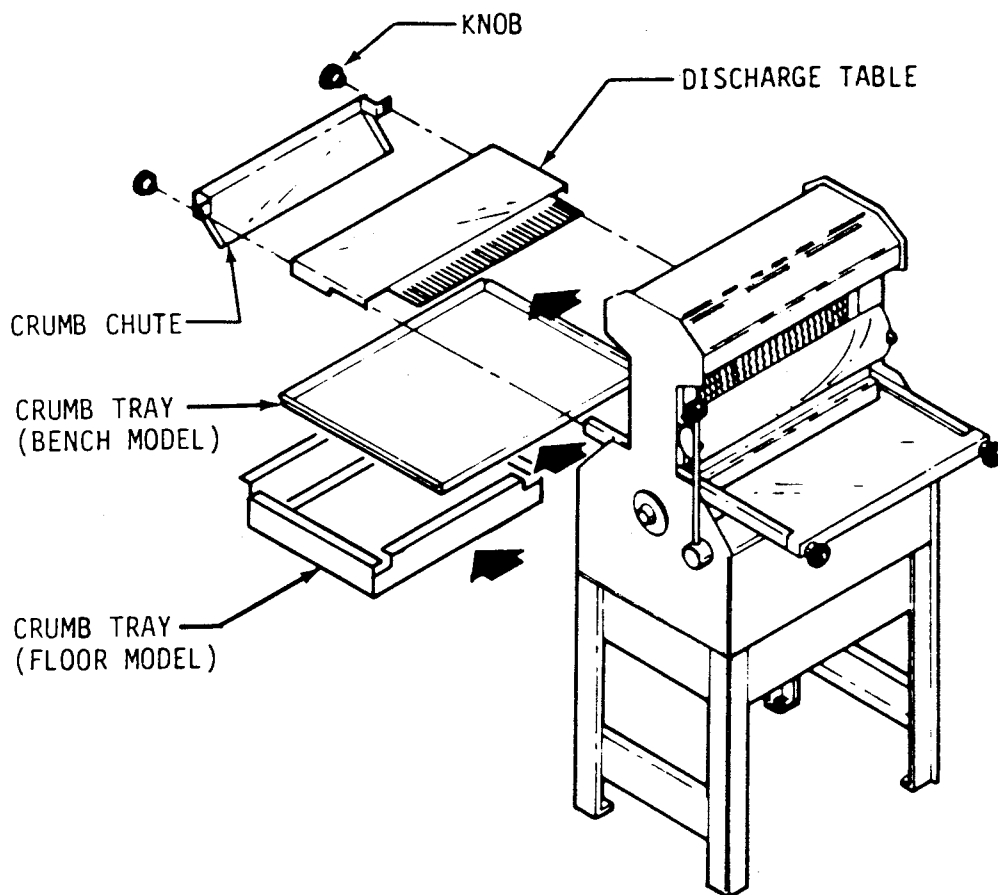

Figure 17. Removing Discharge Table and Crumb Tray

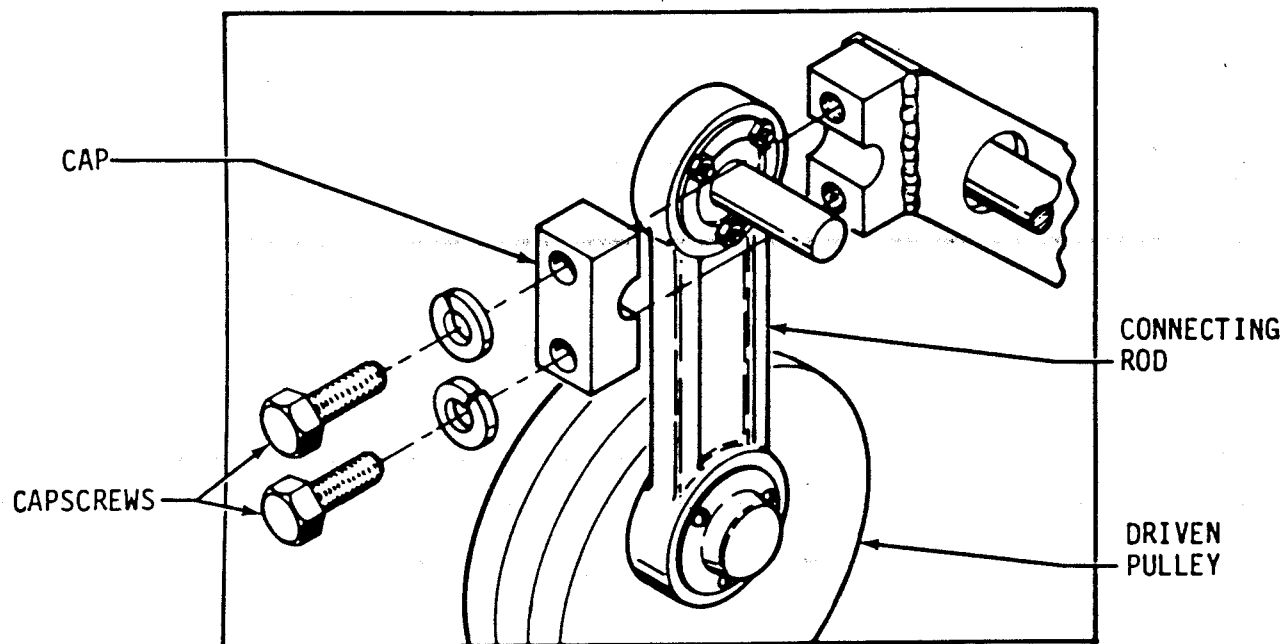

Figure 18. Removing Connecting Rod

LUBRICATION

Once a month put a drop of a food approved lubricant on the four bushings at the top of links, above blade frames. All the other bearings are grease packed and seldom require attention.

CAUTION

NEVER oil or grease the motor.

CLEANING

Once a week remove infeed and discharge tables to allow access for brushing off crumbs found on working parts of slicer. Empty and replace crumb tray as necessary.

BLADE FRAME ADJUSTMENTS

SLICES VARY IN THICKNESS

Remove discharge table from slicer. With a wrench loosen, but do not remove, hex head capscrews in feet of blade frame adjacent to discharge table. Using an allen wrench, loosen setscrew in rocker frame fixed collar. Using a ruler (15 inch maximum) measure the distance between the blades. (Figure 19) Gently tap the collar with a small mallet to the right or left until the distances between the blades are equally spaced. Tighten setscrew and capscrews in blade frame feet.

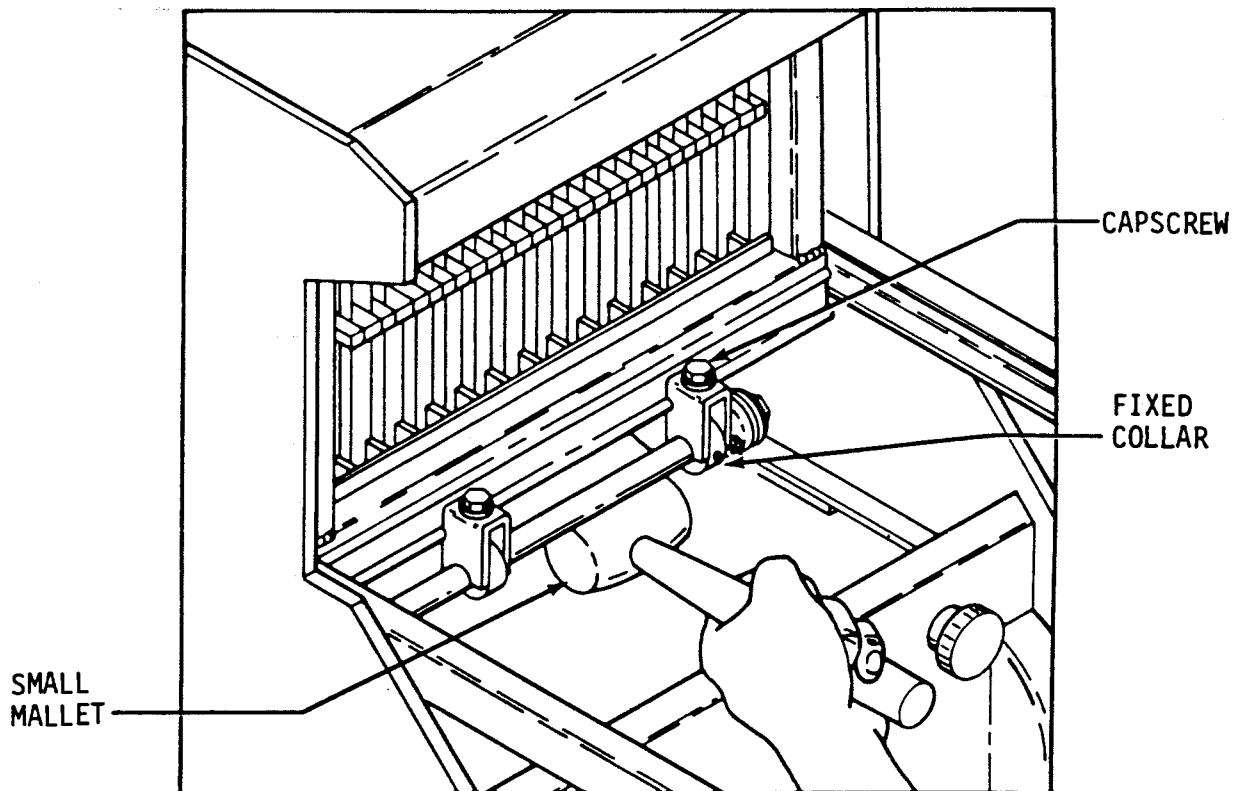

Figure 19. Adjusting Slice Thickness

CLEARANCE BETWEEN BLADE FRAMES

The distance between the blade frames is adjusted by rotating the eccentric pins located above the blade frames. A small screwdriver or rod must be inserted through the hole in the side of the eccentric pin to keep the pin from rotating while loosening locknut on the end of pin with a wrench. (Figure 20)

Using the small screwdriver or rod, rotate pin to the desired position and tighten the nut to lock the pin in place. Check blade frame clearance by turning driven pulley by hand.

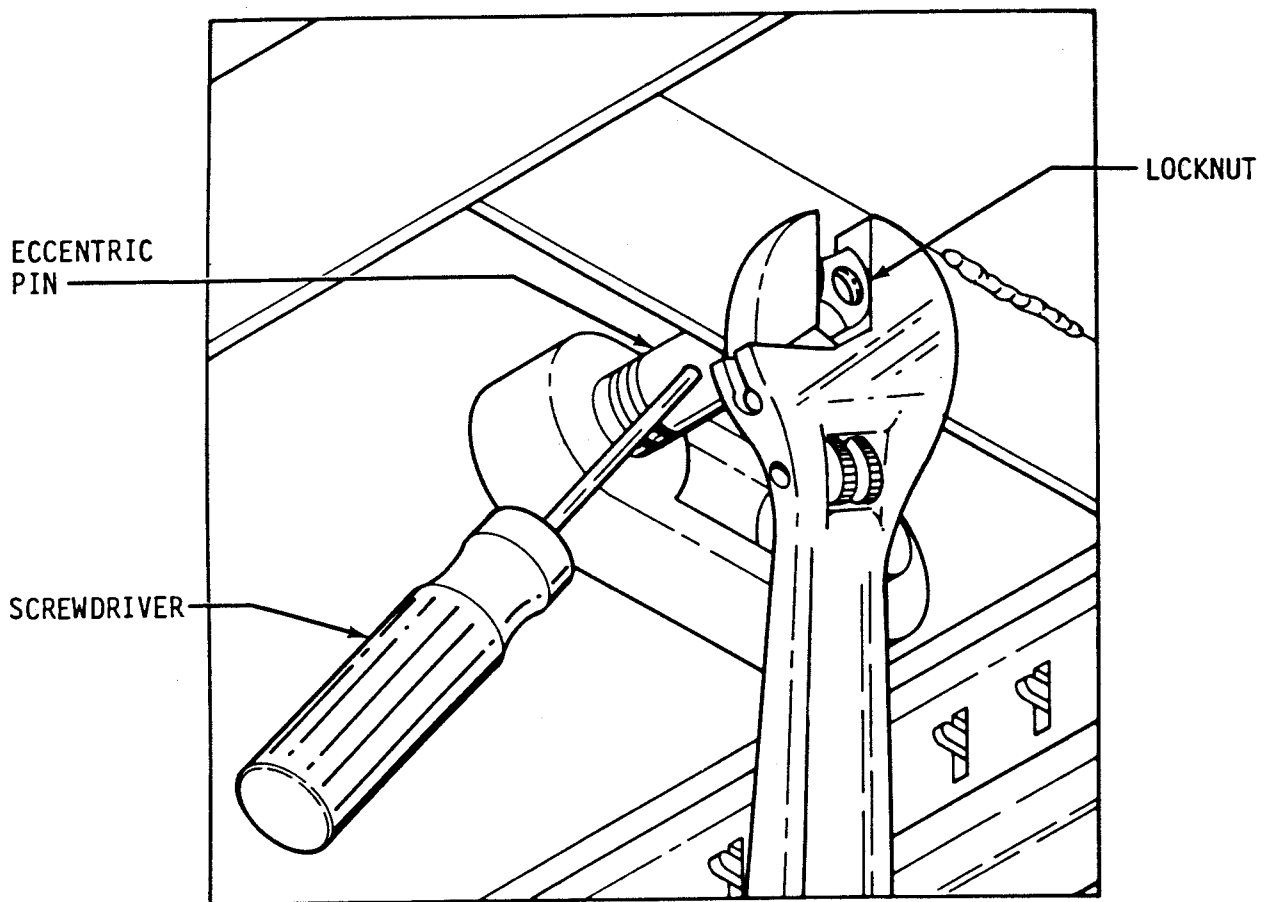

Figure 20. Adjusting Blade Frames Using Eccentric Pins

TROUBLESHOOTING

TROUBLESHOOTING GUIDE

WARNING

ALWAYS UNPLUG SLICER WHEN ADJUSTING OR REPAIRING.

PROBLEM	PROBABLE CAUSE(S)	REMEDY
BREAD SLICES VARY IN THICKNESS	Blade frames out of adjustment.	Adjust blade frames and fixed collar. (Page 19)
BLADE FRAMES KNOCKING	Not enough clearance between frames.	Adjust eccentric pins. (Page 20)
SLICER STOPS BEFORE SLICING STARTS OR IS COMPLETE	Lower limit switch screw.	Adjust limit switch screw. (Figure 21)
	Switch trip mechanism is binding.	Lubricate. (Figure 21)
SLICER DOES NOT STOP WHEN SLICING IS COMPLETE	Upper limit switch screw.	Adjust limit switch screw. (Figure 21)
	Lower limit switch screw.	Adjust limit switch screw. (Figure 21)
SLICER STARTS WITHOUT PULLING KNOB	Switch arm is bent.	Bend back to shape.

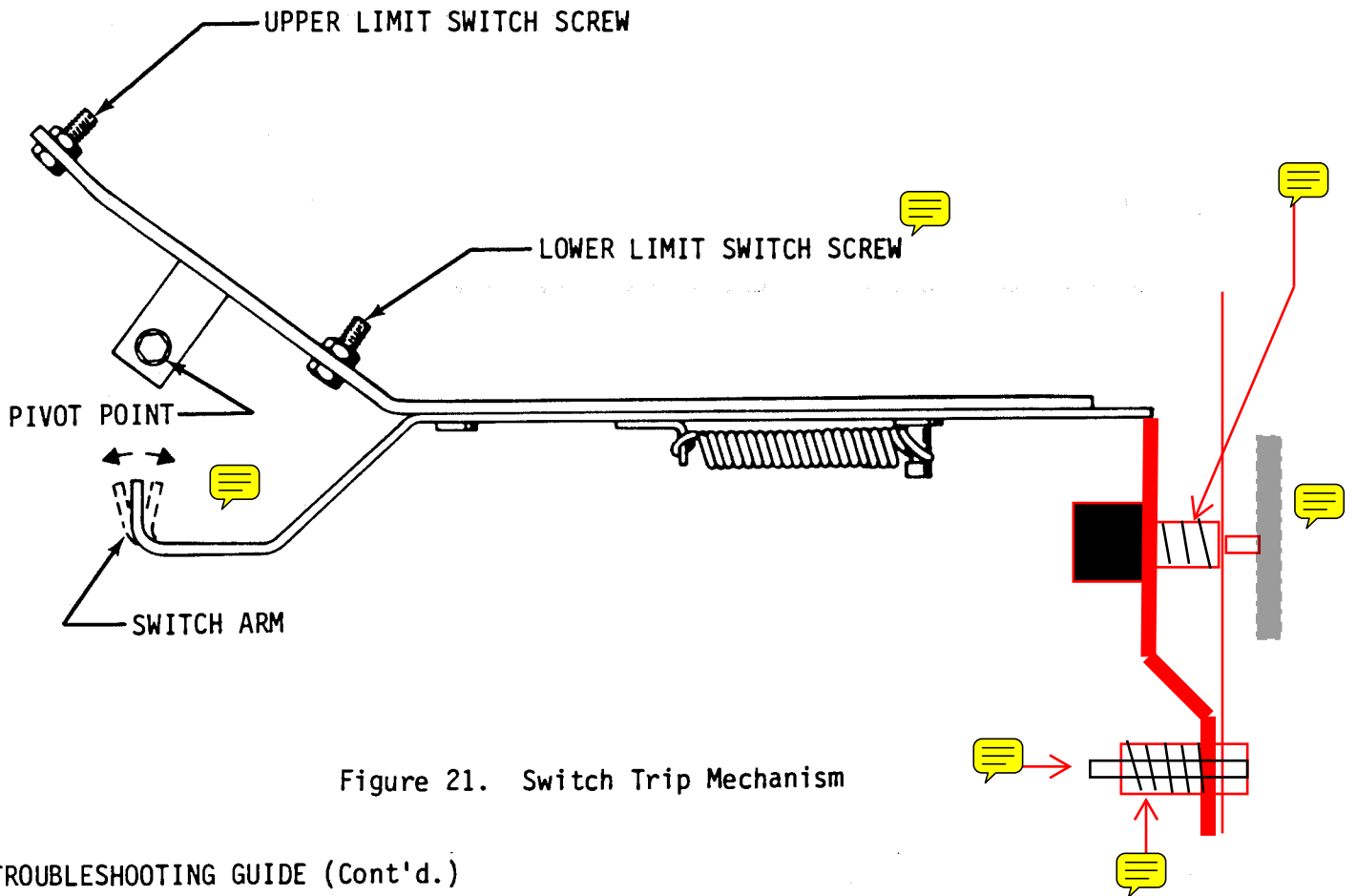

Figure 21. Switch Trip Mechanism

TROUBLESHOOTING GUIDE (Cont'd.)

PROBLEM	PROBABLE CAUSE(S)	REMEDY
SLICER WILL NOT START WHEN KNOB IS PULLED	Switch arm is bent.	Bend back to shape.
SWITCHES TURNED ON, MOTOR HUMS BUT WILL NOT START (SEE CAUTION)	Motor or drive system binding (defective bearings).	Replace or repair.
	Interference between parts of slicer mechanism.	Adjust or repair.

TROUBLESHOOTING GUIDE (Cont'd.)

PROBLEM	PROBABLE CAUSE(S)	REMEDY
SWITCHES TURNED ON, BUT MOTOR DOES NOT START OR HUM	No power at outlet. (Check by plugging lamp or appliance into outlet.)	Repair outlet or circuit.
	Motor switch overload tripped.	Reset following instructions on switch nameplate.
	Switch trip mechanism binding.	Lubricate pivot point. (Refer to Figure 21.)
	Upper limit switch adjustment screw.	Adjust limit switch screw. (Figure 21)
	Bread crumbs in motor starting switch.	Switch should be disassembled and cleaned by a qualified person.

CAUTION

Do not allow motor to hum without starting as this will damage the motor causing it to overheat.

NOTE

Special non-ventilated motor must be used with slicer.

RECOMMENDED SPARE PARTS LIST

PART	DESCRIPTION	NUMBER REQUIRED
5835-7705	CLIP, HAIRPIN	2
0777-0034	PIN, ECCENTRIC	2
0797-0059-2	PIN, BLADE FRAME	2
0711-0002	LINK, TOP	2
5601-1119	BELT, V, 4L290 (60 CYCLE)	1
5601-1120	BELT, V, 4L300 (50 CYCLE)	1
5709-1137	SWITCH, STARTER (1 PHASE)	1
5220-5040	BEARING, DRIVEN PULLEY	1
5220-5041	BEARING, DRIVEN PULLY (SNAP RING)	1
0797-0058-1	STUD, DRIVEN PULLEY	1
6904-6001	GASKET, DRIVEN PULLEY	1
0797-0071-4	ROD, CONNECTING	1
0797-0057-2	STUD, SWING	1
5220-4040	BEARING, ROCKER SHAFT	2
5220-0040	BEARING, SWING SHAFT	4
6904-6000	GASKET, ROCKER SHAFT	3
0777-0917	MOTOR, * 1/2 HP, 1PH, 60HZ, 115/230 V.	1
5757-8140	SWITCH, LIMIT	1

*FOR OTHER MOTORS, CONTACT FACTORY

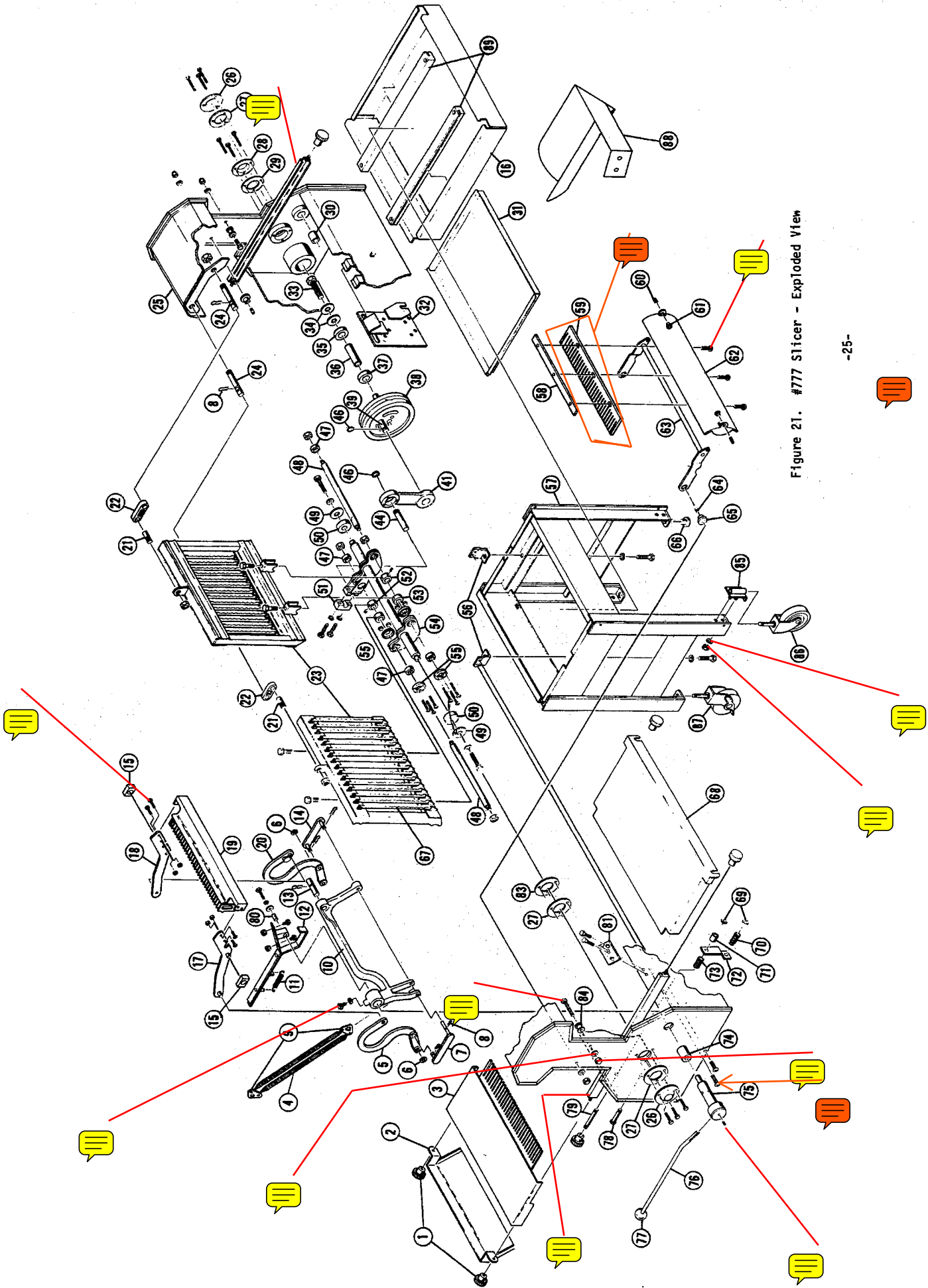

Figure 21. #777 Slicer - Exploded View

MECHANICAL PARTS LIST

NOTE

Items not identified on these sheets or drawings are standard hardware items which may be purchased locally.

ITEM NO.	PART NUMBER	DESCRIPTION	QUANTITY
1	5911-7000	KNOB	5
2	0777-0073-1	CHUTE, CRUMB	1
3	0777-0024-XXX	DISCHARGE TABLE (STATE SLICE WIDTH)	1
4	7025-5101	SPRING, #105	2
5	0777-0082	ARM, FRONT	1
6	0777-0920	WASHER, DELRIN	2
7	0777-0913	LINK, PUSHER	1
8	5835-7705	CLIP, HAIRPIN	10
9	0777-0085	CLIP, SPRING	2
10	0777-0078	YOKE, SWING	1
11	7023-4001	SPRING, #5	1
12	0777-0119-1	SWITCH TRIP MECHANISM	1
13	0777-0033	PIN, YOKE	1
14	0777-0912	LINK, PUSHER	1
15	5500-2800	BLOCK, SLIDE	2
16	0777-0949	TRAY, CRUMB (FLOOR MODEL)	1
17	0777-0077-0002	ARM, PUSHER	1
18	0777-0077-0001	ARM, PUSHER	1
19	0777-0962-XXX	PUSHER (STATE SLICE WIDTH)	1
20	0777-0083	ARM, REAR	1
21	0797-0059-2	PIN, BLADE FRAME	2
22	0711-0002	LINK, TOP	2
23	0797-0300-5XX	FRAME, BLADE (STATE SLICE WIDTH)	2
24	0777-0034	PIN, ECCENTRIC	2
25	0777-0001-2	FRAME, SLICER	1
26	4090-0233-0023	CAP, 39A	2
27	6904-6000	GASKET, ROCKER SHAFT	3
28	4090-0244-0005	CAP, 49A	1
29	6904-6001	GASKET, DRIVEN PULLEY	1
30	0777-0071	BUSHING, MICARTA	1
31	0777-0032-1	TRAY, CRUMB (BENCH MODEL)	1



MECHANICAL PARTS LIST (Continued)

ITEM NO.	PART NUMBER	DESCRIPTION	QUANTITY
32	0777-0100-3	BRACKET, MOTOR	1
35	5220-5041	BEARING, DRIVEN PULLEY (SNAP RING)	1
36	4130-0132-0204	COLLAR, 117B	1
37	5220-5040	BEARING, DRIVEN PULLEY	1
38	0730-0005	PULLEY, DRIVEN (METRIC)	1
39	0797-0058-019	STUD	1
41	0797-0071-4	ROD, CONNECTING	1
44	0797-0057-219	STUD, SWING	1
46	5840-2825	RING, RETAINING	2
47	5220-0040	BEARING, SWING SHAFT	4
48	0797-0060	SHAFT, SWING	2
49	5851-8100	WASHER, SPECIAL	2
50	5220-4040	BEARING, ROCKER SHAFT	2
51	0797-0047-003	CAP, STUD	1
52	0797-0031-1	COLLAR, FIXED	2
53	0797-0031-001	COLLAR	2
54	0777-0047-1	FRAME, ROCKER	1
55	4090-0232-0004	CAP, BEARING	4
56	0777-0046-1	LOCK, FRAME	2
57	0777-0950	BASE	1
58	0777-0055	WEIGHT, BAR	1
59	0797-0092-XXX	GUIDE, BLADE (STATE SLICE WIDTH)	1
60	0777-0067	SCREW, HOLDDOWN PIVOT	2
61	0777-0065	BUSHING, MICARTA	2
62	0777-0070	HOLDDOWN	1



MECHANICAL PARTS LIST (Continued)

ITEM NO.	PART NUMBER	DESCRIPTION	QUANTITY
63	0777-0026	FRAME, HOLDDOWN	1
64	0777-0068	STUD, HOLDDOWN FRAME	2
65	0777-0066	BUSHING, MICARTA	2
66	5902-0001	FOOT, RUBBER	4
67	0797-0029-1	BLADE (STATE SLICE WIDTH)	*
68	0777-0074-001	INFEED TABLE	1
69	0793-0084	WASHER, HORSESHOE	2
70	7012-3101	SPRING, #161	1
71	5902-0100	BUSHING, RUBBER	1
72	0777-0120	STOP, ARM	1
73	7012-3001	SPRING, #100	1
74	0777-0063	BUSHING, MICARTA	1
75	0777-0121-1	HUB, PUSHER	1
76	0777-0915	LEVER, PUSHER	1
77	5911-7002	KNOB	1
78	0799-1109	STUD	1
79	4625-1108-1103	STUD	1
80	5254-0167	BUSHING, BRONZE	1
81	0777-0898	PLATE, SWITCH MOUNTING	1
83	4090-0233-0044	CAP-POWDER COAT WHITE	1
84	5767-1200	GROMMET, RUBBER	2
85**	0777-0947-001	BRACKET, CASTER	4
86**	5902-2347	CASTER	2
87**	5902-2348	CASTER (W/BRAKE)	2
88	0797-2048	TRAY, BAGGER	1
89	0777-0948	TRACK, CRUMB TRAY	2
90	8842-0583	SCREW, HEX HD M10x20mm	1
91	8851-9418	WASHER, SPRING LOCK M10	1
92	8851-8418	WASHER, FLAT M10	1



*CONSULT FACTORY
 **OPTIONAL

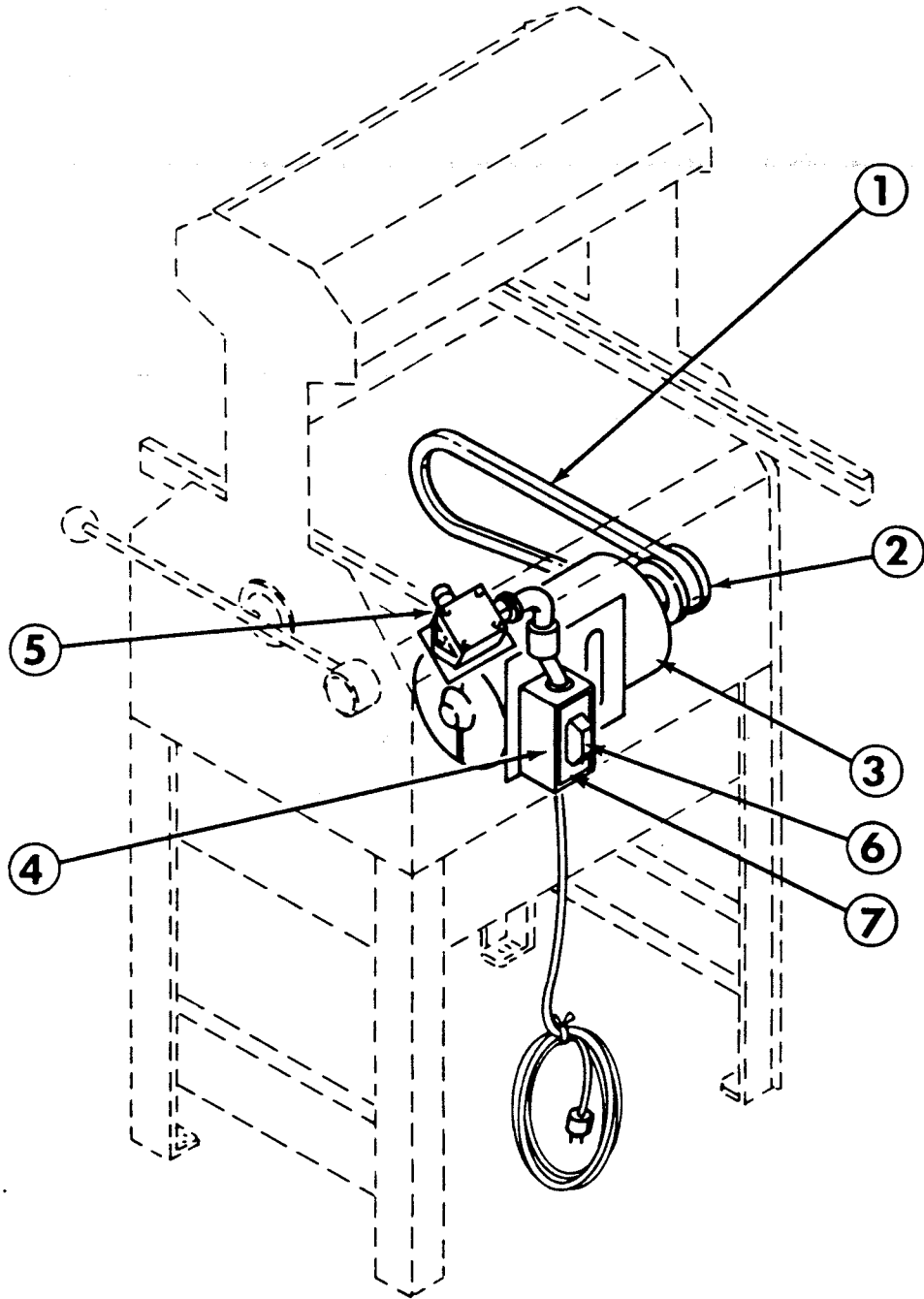

Figure 23. Electrical Components - Single Phase

ELECTRICAL (SINGLE PHASE MACHINES)

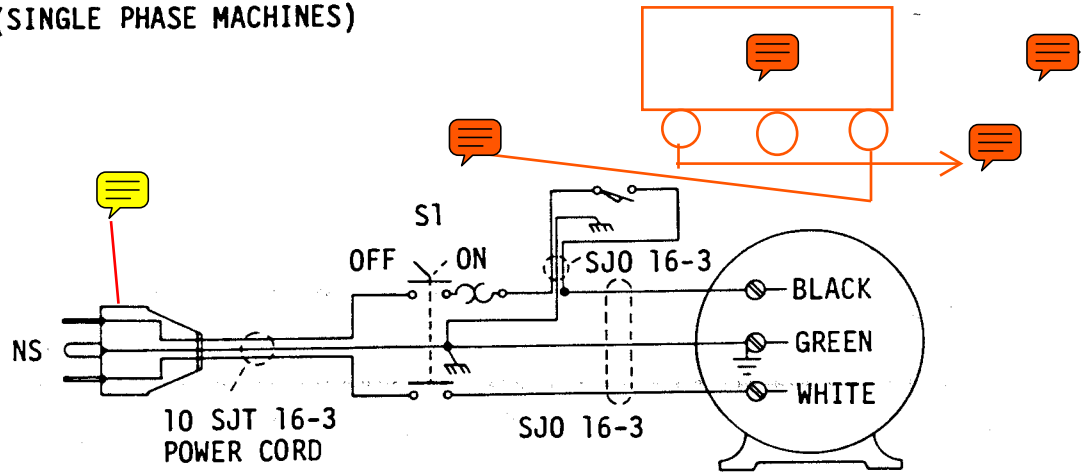

Figure 24. Wiring Diagram - Single Phase

1/2 HP, 115/230 V, 60 Hz, 1 Ph

PARTS LIST (FIGURE 23)			
ITEM NO.	PART NUMBER	DESCRIPTION	QUANTITY
1	5601-1119	BELT, V - 4L290	1
2	4575-7103-2001	PULLEY, Motor	1
3	6301-3609	MOTOR, 1/2 HP	1
4	5709-1137	SWITCH, Starter.	1
5	5757-8140	SWITCH, Limit	1
6	5757-4815	BOOT	1
7	0797-2131	PLATE, Cover	1

* 1/2 HP, 110/220 V, 50 Hz, 1 Ph

PARTS LIST (FIGURE 23)			
ITEM NO.	PART NUMBER	DESCRIPTION	QUANTITY
1	5601-1120	BELT, V - 4L300	1
2	4575-7104-2001	PULLEY, Motor	1
3	0777-0917	MOTOR, 1/2 HP	1
4	5709-1137	SWITCH, Starter	1
5	5757-8140	SWITCH, Limit	1
6	5757-4815	BOOT	1
7	0797-2131	PLATE, Cover	1

* Optional Item

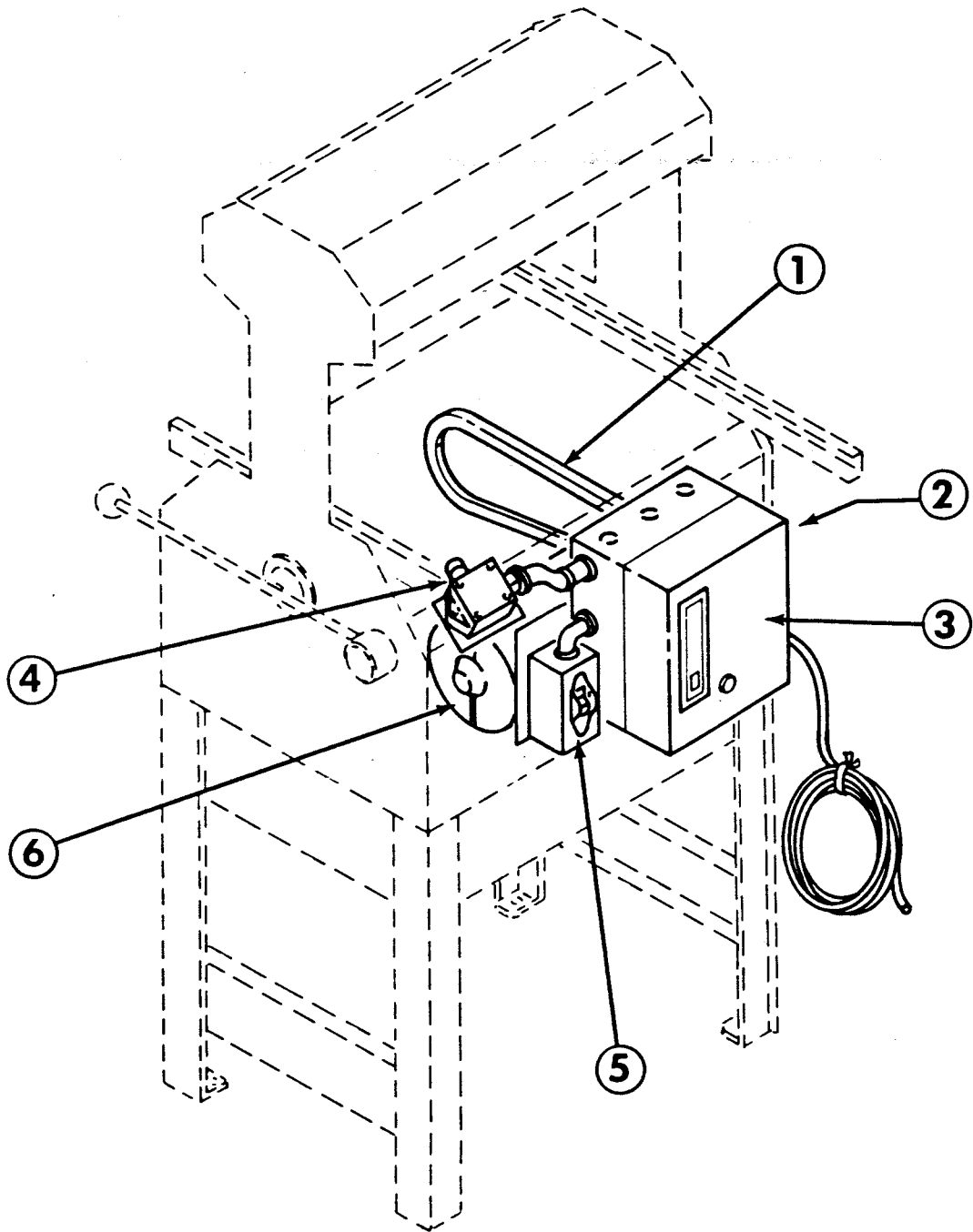

Figure 25. Electrical Components - Three Phase

ELECTRICAL (THREE PHASE MACHINES)

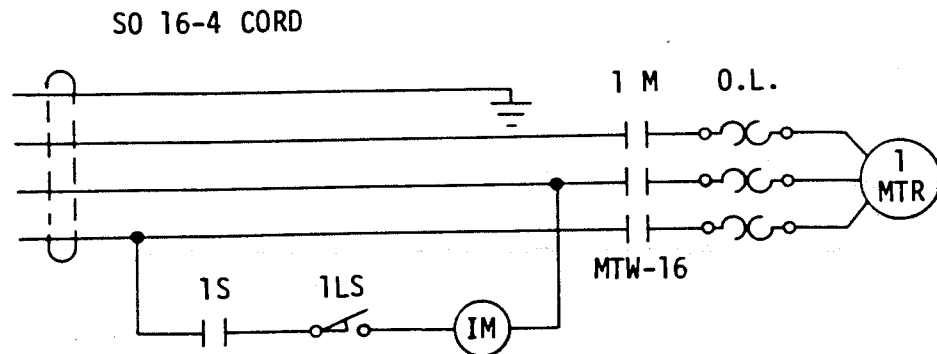

Figure 26. Wiring Diagram - Three Phase

* 1/2 HP, 230 V, 60 Hz, 3 Ph

PARTS LIST (FIGURE 25)			
ITEM NO.	PART NUMBER	DESCRIPTION	QUANTITY
1	5601-1119	BELT, V - 4L290	1
2	4575-7103-2001	PULLEY, Motor	1
3	5709-8823	STARTER, Magnetic	1
4	5757-8140	SWITCH, Limit	1
5	5757-9325	SWITCH, Toggle	1
6	6301-3800	MOTOR, 1/2 HP	1

* 1/2 HP, 460 V, 60 Hz, 3 Ph

PARTS LIST (FIGURE 25)			
ITEM NO.	PART NUMBER	DESCRIPTION	QUANTITY
1	5601-1119	BELT, V - 4L290	1
2	4575-7103-2001	PULLEY, Motor	1
3	5709-8827	STARTER, Magnetic	1
4	5757-8140	SWITCH, Limit	1
5	5757-9325	SWITCH, Toggle	1
6	6301-3800	MOTOR, 1/2 HP	1

* Optional Item

ELECTRICAL (THREE PHASE MACHINES) (CONT'D)

* 1/2 HP, 220 V, 50 Hz, 3 Ph

PARTS LIST (FIGURE 25)			
ITEM NO.	PART NUMBER	DESCRIPTION	QUANTITY
1	5601-1120	BELT, V - 4L300	1
2	4575-7104-2001	PULLEY, Motor	1
3	5709-8823	STARTER, Magnetic	1
4	5757-8140	SWITCH, Limit	1
5	5757-9325	SWITCH, Toggle	1
6	6301-3975	MOTOR, 1/2 HP	1

* 1/2 HP, 380 V, 50 Hz, 3 Ph

PARTS LIST (FIGURE 25)			
ITEM NO.	PART NUMBER	DESCRIPTION	QUANTITY
1	5601-1120	BELT, V - 4L300	1
2	4575-7104-2001	PULLEY, Motor	1
3	5709-8837	STARTER, Magnetic	1
4	5757-8140	SWITCH, Limit	1
5	5757-9325	SWITCH, Toggle	1
6	6301-3975	MOTOR, 1/2 HP	1

* Optional Item

WARRANTY

PARTS

Oliver Products Company (Oliver) warrants that if any part of the equipment (other than a part not manufactured by Oliver) proves to be defective (as defined below) within one year after shipment, and if Buyer returns the defective part to Oliver within one year, Freight Prepaid to Oliver's plant in Grand Rapids, MI, then Oliver, shall, at Oliver's option, either repair or replace the defective part, at Oliver's expense.

LABOR

Oliver further warrants that equipment properly installed in accordance with our special instructions, which proves to be defective in material or workmanship under normal use within one (1) year from installation or one (1) year and three (3) months from actual shipment date, whichever date comes first, will be repaired by Oliver or an Oliver Authorized Service Dealer, in accordance with Oliver's published Service Schedule.

For purposes of this warranty, a defective part or defective equipment is a part or equipment which is found by Oliver to have been defective in materials workmanship, if the defect materially impairs the value of the equipment to Buyer. Oliver has no obligation as to parts or components not manufactured by Oliver, but Oliver assigns to Buyer any warranties made to Oliver by the manufacturer thereof.

This warranty **does not** apply to:

1. Damage caused by shipping or accident.
2. Damage resulting from improper installation or alteration.
3. Equipment misused, abused, altered, not maintained on a regular basis, operated carelessly, or used in abnormal conditions.
4. Equipment used in conjunction with products of other manufacturers unless such use is approved by Oliver Products in writing.
5. Periodic maintenance of equipment, including but not limited to lubrication, replacement of wear items, and other adjustments required due to installation, set up, or normal wear.
6. Losses or damage resulting from malfunction.

The foregoing warranty is in lieu of all other warranties expressed or implied AND OLIVER MAKES NO WARRANTY OF MERCHANTABILITY OR FITNESS FOR PURPOSE REGARDING THE EQUIPMENT COVERED BY THIS WARRANTY. Oliver neither assumes nor authorizes any person to assume for it any other obligations or liability in connection with said equipment. OLIVER SHALL NOT BE LIABLE FOR LOSS OF TIME, INCONVENIENCE, COMMERCIAL LOSS, INCIDENTAL OR CONSEQUENTIAL DAMAGES.

WARRANTY PROCEDURE

1. If a problem should occur, either the dealer or the end user must contact the Customer Service Department and explain the problem.
2. The Customer Service Manager will determine if the warranty will apply to this particular problem.
3. If the Customer Service Manager approves, a Work Authorization Number will be generated, and the appropriate service agency will perform the service.
4. The service dealer will then complete an invoice and send it to the Customer Service Department at Oliver Products Company.
5. The Customer Service Manager of Oliver Products Company will review the invoice and returned parts, if applicable, and approve for payment.

RETURNED PARTS POLICY

This policy applies to all parts returned to the factory whether for warranted credit, replacement, repair or re-stocking.

Oliver Products Company requires that the customer obtain a Return Material Authorization (RMA) number before returning any part. This number should appear on the shipping label and inside the shipping carton as well. All parts are to be returned prepaid. Following this procedure will insure prompt handling of all returned parts.

To obtain an RMA number contact the Repair Parts Department toll free at (800) 253-3893.

Parts returned for re-stocking are subject to a **RE-STOCKING CHARGE**.

Thank you for your cooperation,

Repair Parts Manager
Oliver Products Company