



Grand Rapids, Michigan, U.S.A. 49504-5298

**USER'S OPERATING AND INSTRUCTION MANUAL**

**MODELS 797-32N, 797-32NC & 797-48N**

BREAD SLICERS



**797-N BREAD SLICER**

**INDEX**

<u>Section Description</u>	<u>Document No.</u>	<u>Page No.</u>
SAFETY INSTRUCTIONS -----	0797S20021 -----	1-1
DESCRIPTION/SPECIFICATIONS -----	0797S20022 -----	2-1
Description -----		2-1
Specifications -----		2-1
INSTALLATION INSTRUCTIONS -----	0797S20023 -----	3-1
Removing the Slicer from the Shipping Skid -----		3-1
Installing Optional Casters -----		3-2
OPERATING INSTRUCTIONS -----	0797S20024 -----	4-1
Adjusting the Gravity Feed Slicer's Holddown -----		4-1
Adjusting the Slicer for Product Length -----		4-2
Adjusting the Outfeed Side Guides on a Standard Outfeed Table -----		4-3
Operating a Gravity Feed Slicer -----		4-4
Operating the Gravity Feed's Last Loaf Pusher -----		4-4
TROUBLESHOOTING -----	0797S20025 -----	5-1
The Slicer Will Not Start (Motor is Not Humming) -----		5-1
The Slicer Will Not Start (Motor is Humming) -----		5-1
Bread Slices Vary in Thickness -----		5-2
The Blade Frames are Knocking -----		5-2
The Slicer Vibrates Excessively -----		5-2
The Bread is Cutting Slowly or is Being Damaged -----		5-2
MAINTENANCE -----	0797S20026 -----	6-1
Cleaning -----		6-1
Lubrication -----		6-1
Removing the Blade Frames -----		6-2
Changing the Blades -----		6-6
Tightening the Belt -----		6-8
Replacing the Belt -----		6-10
Adjusting the Blade Frames When Slices Vary in Thickness -----		6-11
Adjusting the Clearance Between the Blade Frames -----		6-12
RECOMMENDED SPARE PARTS -----	0797S20027 -----	7-1
REPLACEMENT PARTS SECTION		
MAIN FRAME & ROCKER -----	0797S20028 -----	8-1
Drawing -----		8-1
Parts List -----		8-2
BASE & CASTER -----	0797S20029 -----	9-1
Drawing -----		9-1
Parts List -----		9-2

Continued



---

---

## 797-N BREAD SLICER

---

---

### INDEX (Continued)

#### REPLACEMENT PARTS SECTION (Continued)

<u>Section Description</u>	<u>Document No.</u>	<u>Page No.</u>
SLICE PARTS & HOLDDOWN -----	0797S20030 -----	10-1
Drawing -----		10-1
Parts List -----		10-2
32 INCH GRAVITY INFEED CHUTE -----	0797S20031 -----	11-1
Drawing -----		11-1
Parts List -----		11-2
48 INCH GRAVITY INFEED CHUTE -----	0797S20032 -----	12-1
Drawing -----		12-1
Parts List -----		12-2
32 INCH COMBINATION INFEED CHUTE -----	0797S20058 -----	13-1
Drawing -----		13-1
Parts List -----		13-2
STANDARD OUTFEED -----	0797S20033 -----	14-1
Drawing -----		14-1
Parts List -----		14-2
DRIVEN PULLEY -----	0797S20034 -----	15-1
Drawing -----		15-1
Parts List -----		15-2
SINGLE PHASE ELECTRICAL -----	0797S20035 -----	16-1
Wiring Diagram -----		16-1
Drawing -----		16-1
Parts Lists -----		16-2
THREE PHASE ELECTRICAL -----	0797S20036 -----	17-1
Wiring Diagram -----		17-1
Drawing -----		17-1
Parts Lists -----		17-2
WARRANTY -----	GEN 040225	
WARRANTY PROCEDURE -----	GEN 040226	
RETURNED PARTS POLICY -----	GEN 040227	



---

---

## 797-N BREAD SLICER

---

---

### SAFETY INSTRUCTIONS

#### **WARNING**

**VARIOUS SAFETY DEVICES AND METHODS OF GUARDING HAVE BEEN PROVIDED ON THIS MACHINE. IT IS ESSENTIAL HOWEVER THAT THE MACHINE OPERATORS AND MAINTENANCE PERSONNEL OBSERVE THE FOLLOWING SAFETY PRECAUTIONS. IMPROPER INSTALLATION, MAINTENANCE, OR OPERATION OF THIS EQUIPMENT COULD CAUSE SERIOUS INJURY OR DEATH.**

1. Read this manual before attempting to operate your machine. Never allow an untrained person to operate or service this machine.
2. Connect the machine to a properly grounded electrical supply that matches the requirements shown on the electrical specification plate and follow all specifications of local electrical codes.
3. Disconnect and lock-out the machine from the power supply before cleaning or servicing.
4. Check and secure all guards before starting the machine.
5. Observe all caution and warning labels affixed to the machine.
6. Use only proper replacement parts.
7. Do not wear loose fitting clothing or loose hair when working near this machine. Shirt tails should be tucked in.
8. Wear proper, personal, protective, safety equipment.
9. Keep Hands away from the moving parts of this machine while it is in operation.
10. In addition to these general safety instructions, please follow the more specific safety instructions in the rest of this operating instruction manual.

#### **WARNING**

**DO NOT USE FOR OTHER THAN ORIGINALLY INTENDED PURPOSE.**

**THIS PAGE WAS INTENTIONALLY  
LEFT BLANK.**



## 797-N BREAD SLICER

### DESCRIPTION/SPECIFICATIONS

#### Description

The Oliver Model 797-N series of Bread Slicers are of a compact, sturdy, time tested design, which has been used in bakeries worldwide for many years. The machine is easy to operate, with its gravity fed infeed chute, allowing production slicing of product in quantities of up to 600 loaves per hour. Speed is of course dependent on condition of the machine, sharpness of its knives and the texture of the actual product being sliced. Its design will provide years of efficient, trouble-free operation requiring a minimum of maintenance.

The Model 797-N series of Bread Slicers are of stainless, plated, and painted steel construction for easy cleaning and maintenance. Most operators will be able to replace the knives without the need of a service call.

Oliver Products Company, who has a reputation of serving the Baking Industry for well over 60 years, backs these slicers.

#### Specifications

**Space Requirements: Models 797-32N, (Shown), & 797-32NC**  
(All Dimensions are Approximate)

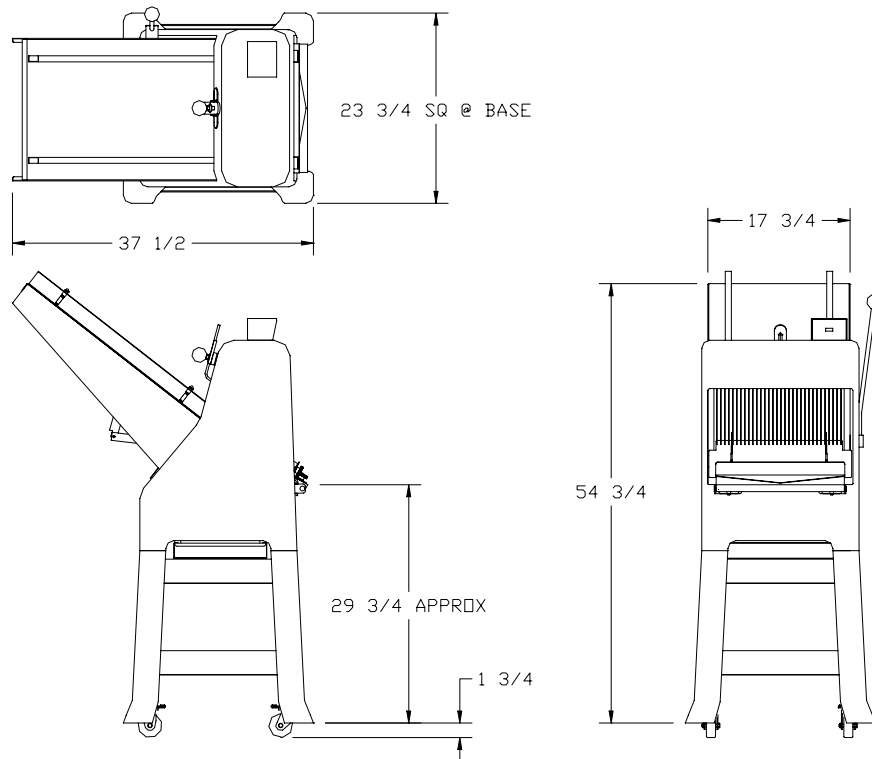



## 797-N BREAD SLICER

**Space Requirements: Models 797-48N**  
(All Dimensions are Approximate)

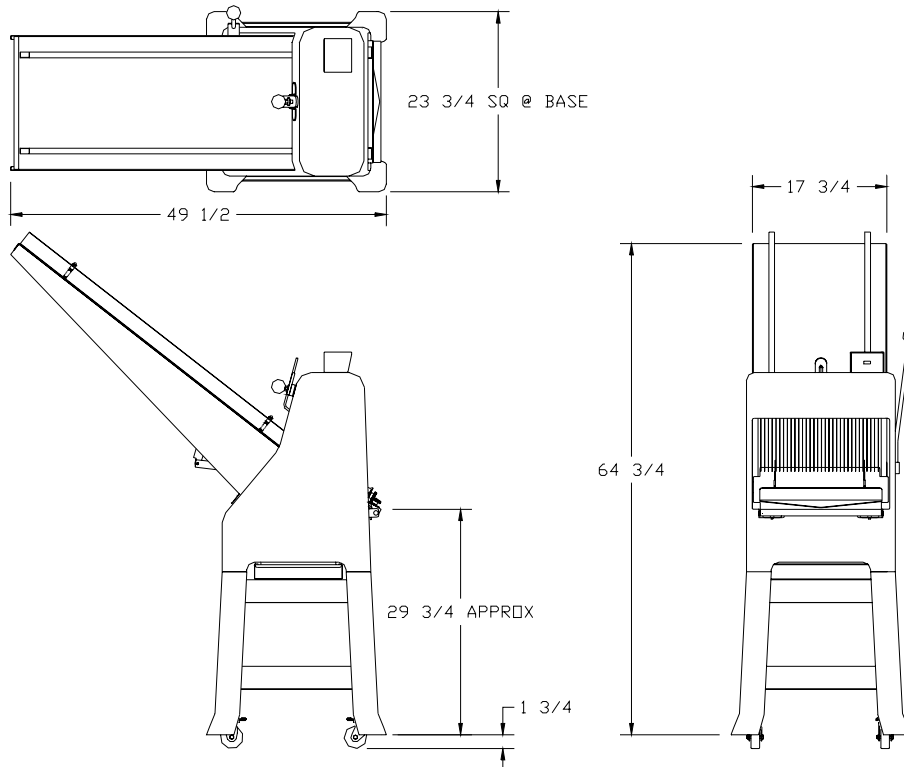

### Product Capacities:

Up to 16 inches long and in the range of 2 to 5 inches high.

*Standard Electrical Options: (Others available at additional cost -- consult factory).*

- 1 phase, 60 hz, 115VAC, 7 Amps.
- 1 phase, 60 hz, 230VAC, 3.5 Amps.

*Standard Slice Spacings, (Models 797-32N & 797-48N)*

7/16, 1/2, 9/16 (inches)

*Optional Slice Spacings, (Models 797-32N & 797-48N) (At additional cost).  
(Specials available -- consult factory).*

1/4 (min.), 5/16, 3/8, 5/8, 11/16, 3/4, 13/16, 7/8, 1, 1-1/4 (inches)

### Shipping Weight

250 lbs. approximate

Rev. 9-6-31



## 797-N BREAD SLICER

### INSTALLATION INSTRUCTIONS

#### *Removing the Slicer from the Shipping Skid*

After removing the carton you should find the basic slicer completely assembled and strapped to the shipping skid. Cut both straps to free the slicer from the skid.

### **CAUTION**

**THE SLICER IS HEAVY, USE PROPER TECHNIQUE WHEN LIFTING.  
KEEP BACK STRAIGHT, KNEES BENT, AND LIFT WITH LEGS.  
USE GLOVES TO PROTECT HANDS.**

As shown in the illustration below, lift the slicer off the shipping skid with one person standing on each side of the slicer. Set the slicer down on a level floor after which it may be moved to the desired location.

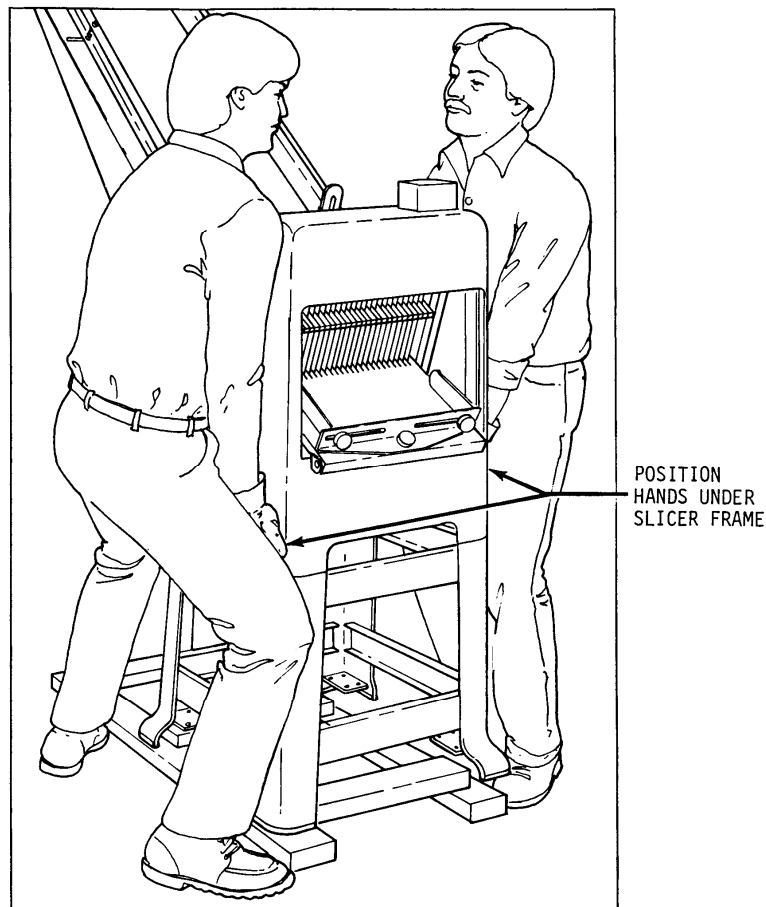



## 797-N BREAD SLICER

### CASTER INSTALLATION INSTRUCTIONS

Place blocks on the floor approximately (8) and (38) inches from the discharge side of the slicer, see the illustration below. Lower the holddown to its lowest position and tighten the adjustment knob to prevent the outfeed table from swinging out. With one person on each side of the slicer, gently lower the slicer onto the blocks.

### **CAUTION**

**NEVER ATTEMPT TO LIFT THE SLICER BY ITS INFEED CHUTE AS DAMAGE TO THE MACHINE MAY RESULT.**

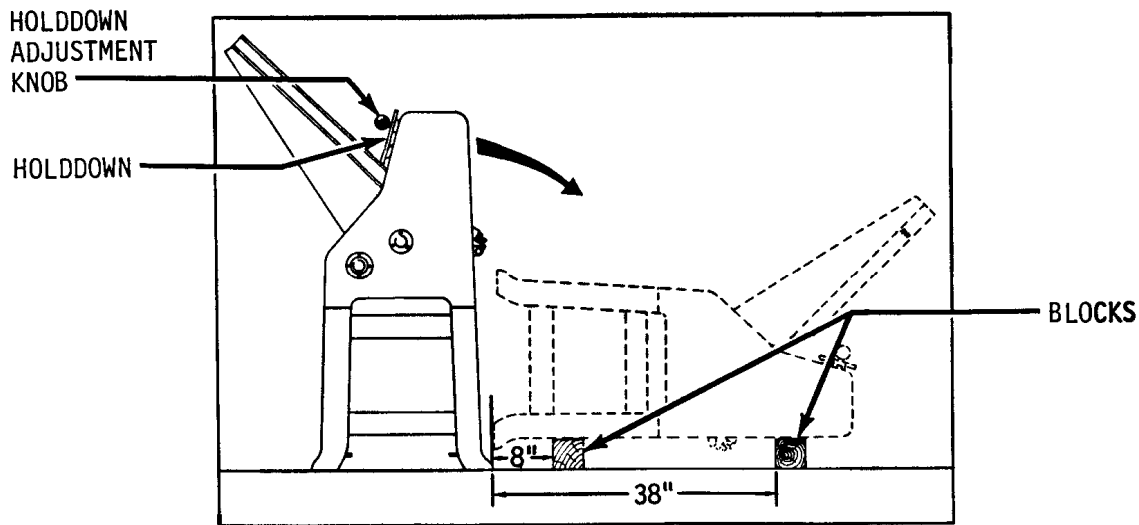

Locate the casters, ¼-inch bolts, lock washers, and nuts in the option package. Install the casters using the furnished hardware as shown in the figure on the next page tighten the bolts and nuts securely using two wrenches. Install both locking casters on the discharge side of the machine. See the next illustration. Set the brakes tightly on both locking casters, (this will help to keep the wheels from rolling when lifting the slicer back to its upright position).

Install the two rigid casters in the same manner on the infeed side of the slicer.



## 797-N BREAD SLICER

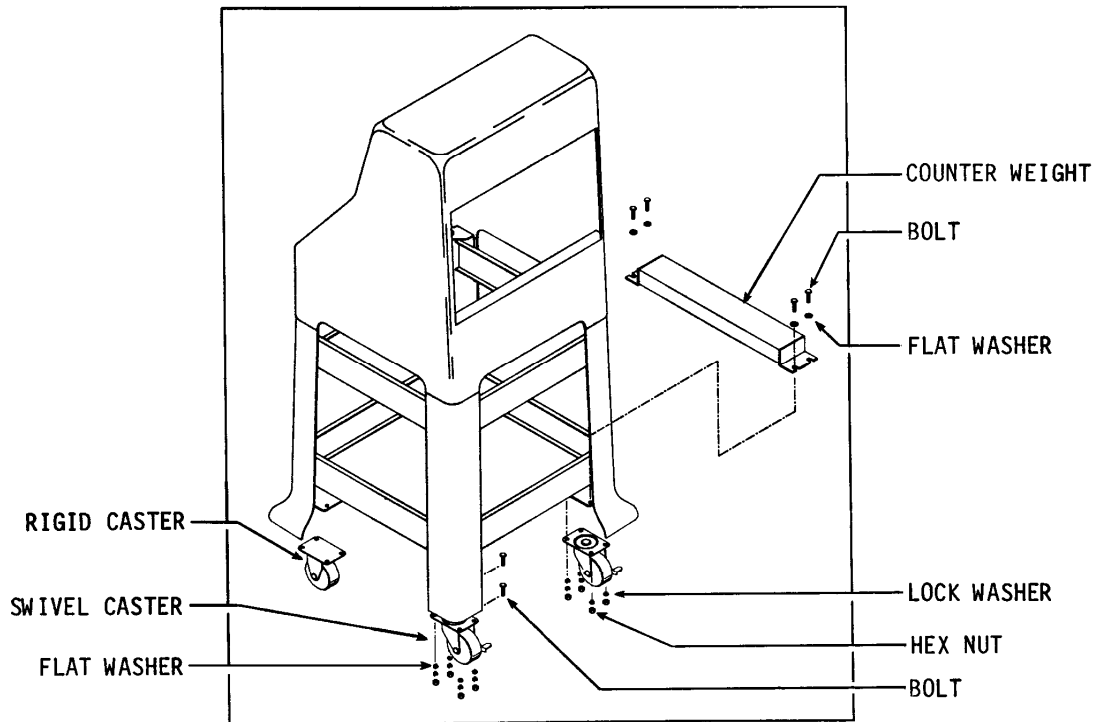

On all slicers equipped with either the Power Belt infeed chute option, or a Model 1179S bagger, a counter weight must be attached to the caster brackets on the right hand side of the machine, (as viewed from the outfeed side of the slicer). See the above illustration. This counter weight must not be removed. Use the same hardware used to secure the weight to attach the casters when both are used. Add additional bolts, washers and nuts on those caster plate holes not involved with the weight mounted as shown. Install one rigid caster and one swivel caster on the right hand side of the machine, (the weight side). Remember, the rigid casters must be installed on the infeed side of the machine.

Install the remaining two casters as previously described, setting their brakes tightly.

After completing the installation, chock the locked wheels using a 2 x 4 to ensure that they will not roll or skid when lifting the slicer back to the upright position. Once the machine is upright release the brakes and roll the slicer to its desired location.

Rev. 8/3/04



---

---

## 797-N BREAD SLICER

---

---

### OPERATING INSTRUCTIONS

#### **CAUTION**

**ALWAYS USE CARE WHENEVER WORKING NEAR THE CUTTING KNIVES.**

*Adjusting the Gravity Feed Slicer's Holddown, (Models 797-32N & 797-48N)*

Loosen the holddown adjustment knob. Adjust the holddown so that the product just clears the bottom edge of the holddown as it passes through the cutting knives. Tighten the holddown adjustment knob when the holddown is in the desired location. See the illustration below. Proper adjustment of the holddown will prevent the product from jumping as it passes through the cutting knives increasing cutting efficiency.

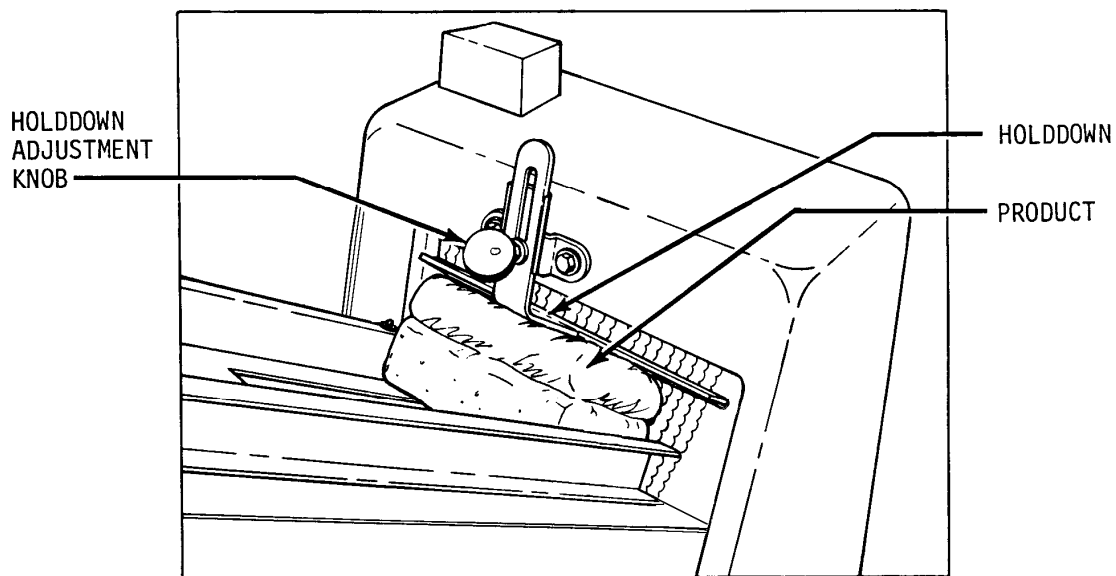



---

---

## 797-N BREAD SLICER

---

---

### *Adjusting the Slicer for Product Length*

Using a typical product, adjust the infeed chute side guides by applying hand pressure. See the next illustration. Set the side guides approximately 1/8 inch wider than the longest expected product.

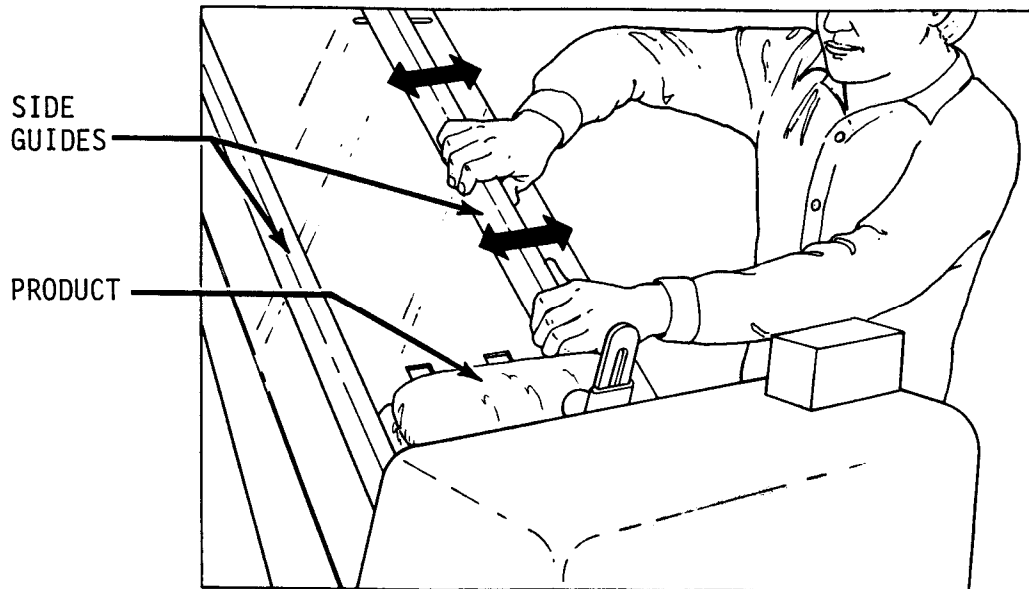

### *Adjusting the Outfeed Side Guides on a Standard Outfeed Table*

Adjust the side guide extensions so that they are approximately 1/4 inch from the cutting knives. Loosen the outfeed guide adjustment knobs. Adjust the outfeed side guides to align with the infeed guides. See the illustration, which follows. Once satisfied with the location re-tighten the side guide adjustment knobs. Proper adjustment of these guides will keep the end slices from falling over as the product exits the cutting knives.



## 797-N BREAD SLICER

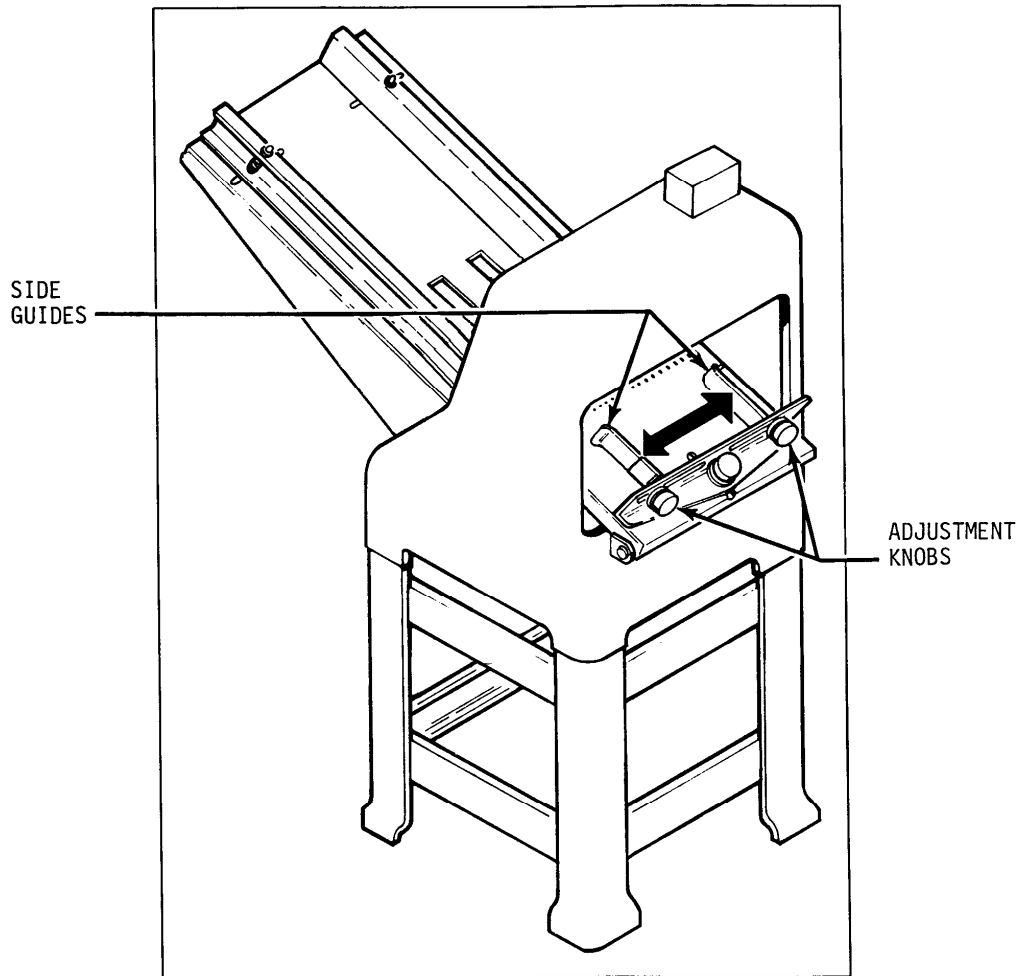

### **NOTE**

**OPTIONAL OUTFEED TABLE GUIDES ARE ADJUSTED WITH HAND PRESSURE IN A FASHION SIMILAR TO THAT OF THE INFEED GUIDES. AS WITH THE STANDARD OUTFEED TABLE ALIGN THE OUTFEED GUIDES WITH THE INFEED GUIDES.**

#### *Operating a Gravity Feed Slicer*

Once the slicer has been properly adjusted for product clearance, the infeed chute may be loaded with the product to be sliced. Flipping the starting switch to the **ON** position will begin operation. Remove each sliced product from the discharge table as it is sliced.



## 797-N BREAD SLICER

### **NOTE**

**THE GRAVITY FEED SLICER'S OPTIMUM OPERATING EFFICIENCY WILL BE MAINTAINED BY ENSURING THAT THE INFEED CHUTE IS KEPT FULLY LOADED. THE ACTUAL SPEED OF SLICING IS DEPENDENT ON THE NUMBER OF PRODUCTS IN POSITION ON THE INFEED CHUTE, SHARPNESS OF CUTTING KNIVES, AND TEXTURE OF THE PRODUCT.**

#### *Operating the Gravity Feed's Last Loaf Pusher, (Models 797-32N & 797-48N)*

32 inch and 48 inch gravity feed slicers are equipped with a last loaf pusher to assist in feeding the last product on the infeed chute through the cutting knives. To operate the last loaf pusher, slowly pull the last loaf pusher lever toward the discharge side of the slicer. See the next illustration. Return the lever to the upper position before reloading the infeed chute.

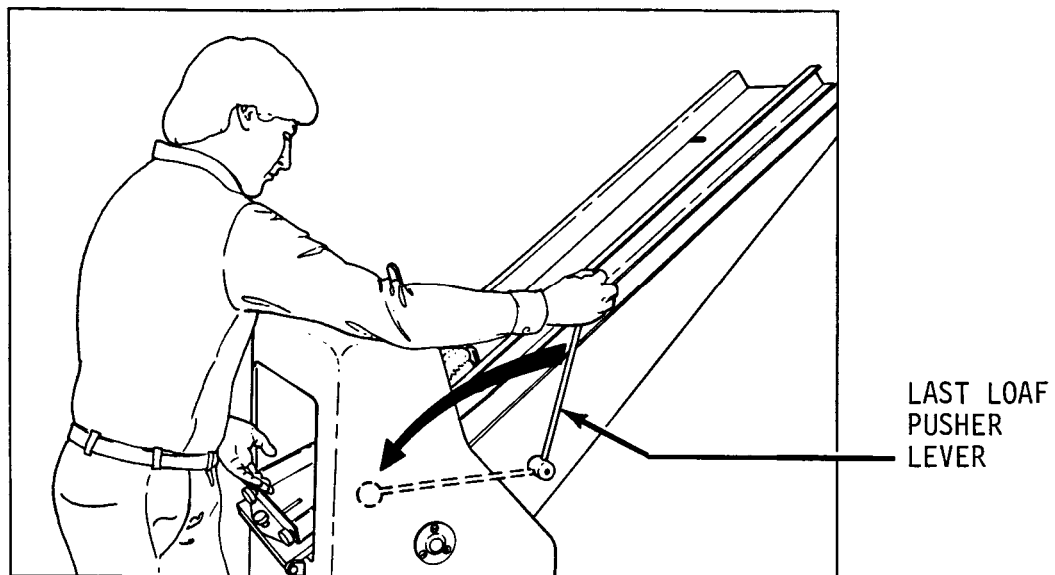

(Continued)



---

---

## 797-N BREAD SLICER

---

---

*Operating the Gravity Feed's Last Loaf Pusher (continued)*

### **CAUTION**

**THE KNIVES ARE EXTREMELY SHARP.  
DO NOT TOUCH MOVING OR STATIONARY KNIVES.**

Once the last loaf pusher has fed the product into the cutting knives as far as it can, it may be necessary to pull the product the rest of the way through the knives by hand.

### **NOTE**

**THE MODEL 797-32NC HAS A CENTER MOUNTED  
HAND OPERATED THROUGH THE KNIFE PUSHER.**



---

---

## 797-N BREAD SLICER

---

---

### TROUBLESHOOTING

#### **WARNING**

**ALWAYS DISCONNECT THE SLICER FROM THE POWER SUPPLY BEFORE ATTEMPTING ANY TYPE OF MAINTENANCE TASK, INCLUDING TROUBLESHOOTING.**

*The Slicer Will Not Start (Motor Is Not Humming)*

- The machine is not plugged in.
- There is no power at the outlet. (Check by plugging in a small working appliance, like a lamp. Check to see if a circuit breaker has tripped. If the circuit breaker has not tripped and the circuit is still not working have a qualified electrician check the circuit.)
- The motor switch overload has tripped. (To reset push firmly in the direction shown on the switch nameplate.)
- There are breadcrumbs in the motor starting switch. (Have a qualified electrician disassemble the switch and clean it.)
- The problem is somewhere in the electrical system of the machine. (Have a qualified electrician find and repair the problem.)

*The Slicer Will Not Start (Motor Is Humming)*

#### **CAUTION**

**DO NOT ALLOW THE MOTOR TO HUM WITHOUT STARTING. OVERHEATING CAN PERMANENTLY DAMAGE THE MOTOR.**

- The motor has failed. (Have it checked by a qualified electrician.)

#### **NOTE**

**A SPECIAL NON-VENTILATED MOTOR MUST BE USED WITH THIS SLICER.**

- The drive system is binding. (Have a qualified service agent check for defective bearings or other restrictions to free movement.)



---

---

## 797-N BREAD SLICER

---

---

- There is mechanical interference between other parts of the slicer. (Have a qualified service agent evaluate the machine for adjustment or replacement of defective parts.)

### *Bread Slices Vary in Thickness*

- The blade frames are out of adjustment. (See the “Maintenance” section of this manual under “Adjusting the Blade Frames When Slices Vary in Thickness” on how to correct this problem.)

### *The Blade Frames Are Knocking*

- The blade frames are out of adjustment. (See the “Maintenance” section of this manual under “Adjusting the Clearance Between the Blade Frames” on how to perform this adjustment.)

### *The Slicer Vibrates Excessively*

- The drive belt is loose or worn. (See the “Maintenance” section of this manual under “Tightening the Belt” or “Replacing the Belt” on how to make these corrections.)
- One or more of the bearings on the machine are failing. (Have a qualified service agent check for defective bearings and replace them as required.)
- The pins, (two eccentrics and two regular), and links at the top of the blade frames are worn. We suggest that these be replaced together. Mixing worn parts with new will shorten the life of the replacement parts. Remember, after replacing the pins and links the clearance between the blade frames must be re-adjusted. (See the “Maintenance” section of this manual under “Adjusting the Clearance Between the Blade Frames” on how to perform this adjustment.)

### *The Bread is Cutting Slowly or is Being Damaged*

- The machine’s holddown is either missing or improperly adjusted. (See the “Maintenance” section of this manual under “Adjusting the Gravity Feed Slicer’s Holddown” on how to perform this adjustment.)
- The knives of the machine have become worn, (dull). (See the “Maintenance” section of this manual under “Changing the Cutting Knives”). Most owners can perform this item of maintenance without calling a service company.
- The blades are not aligned properly. (See the “Maintenance” section of this manual under “Adjusting the Clearance Between the Blade Frames” on how to perform this adjustment.)



---

---

## 797-N BREAD SLICER

---

---

### MAINTENANCE

### **WARNING**

**ALWAYS DISCONNECT THE SLICER FROM THE POWER SUPPLY BEFORE ATTEMPTING ANY TYPE OF MAINTENANCE TASK.**

#### *Cleaning*

Use a mild detergent solution to clean all exterior surfaces and empty the crumb tray daily or more often if necessary. Periodically swing out the discharge table to allow access to the drive area of the machine, then brush, blow, (if compressed air is available), or wipe all foreign material from all surfaces, especially from moving parts.

#### *Lubrication*

Once a month, more often during heavy use, put a drop of food approved lubricant on each of the pivot points, of the plastic links, at the top to the blade frames. All other bearings are either grease packed or sealed and seldom need attention.

### **CAUTION**

**NEVER OIL OR GREASE THE MOTOR.**



---

---

## 797-N BREAD SLICER

---

---

### *Removing the Blade Frames*

## **WARNING**

**ALWAYS DISCONNECT THE SLICER FROM THE POWER SUPPLY BEFORE ATTEMPTING ANY TYPE OF MAINTENANCE TASK.**

Swing out the discharge table from the slicer. See the next illustration.

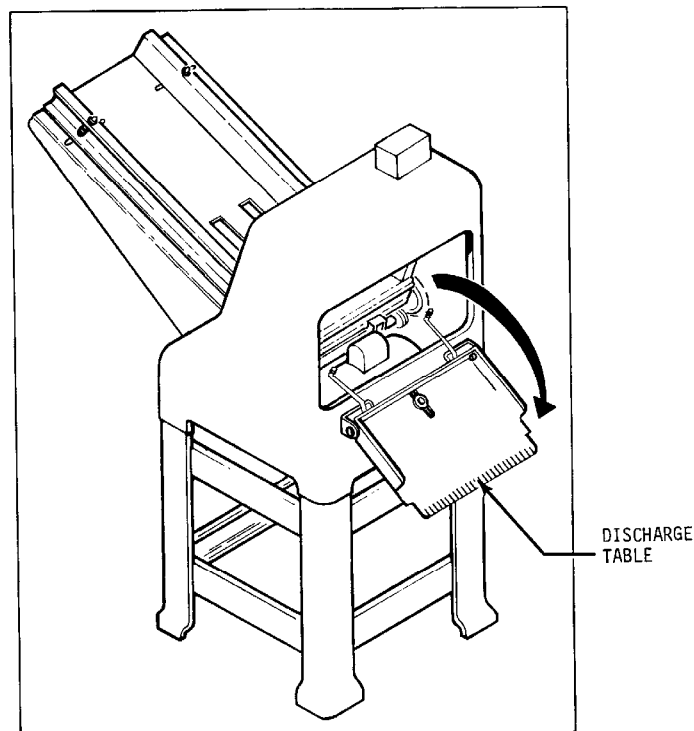

Always start by removing the discharge side blade frame first. Both blade frames should be removed from the discharge side of the machine. You should remove the discharge side blade frame completely from the machine before starting on the infeed side blade frame. However each is removed using similar procedures.

## 797-N BREAD SLICER

### Removing the Blade Frames (Continued)

### NOTE

**NEVER LOOSEN THE NUTS ON THE ECCENTRIC PINS OR ATTEMPT TO REMOVE THEM TO AID IN REMOVING THE BLADE FRAMES.**

Start by pulling the hairpin clip from the eccentric pin, located at the top of each blade frame, see illustration below, then slide the top link toward the eccentric pin's mounting plate. Make sure that the link is forced all the way over to the plate.

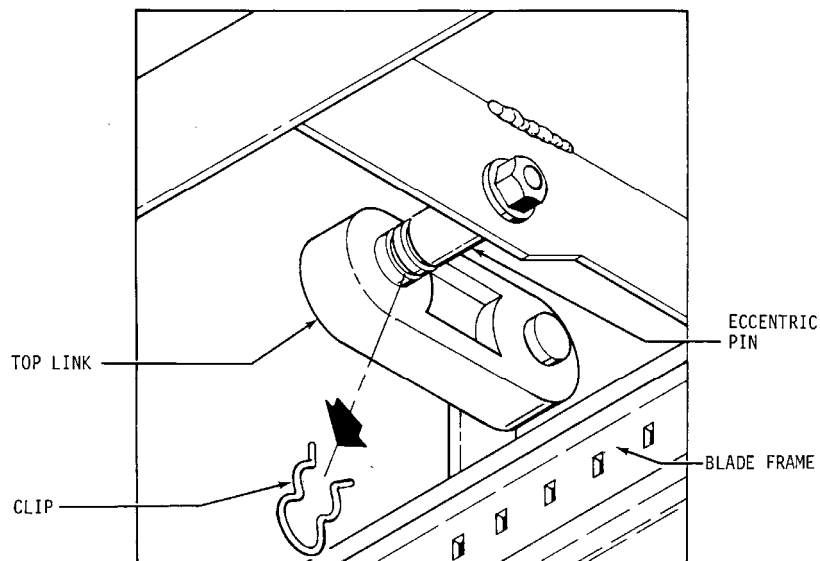

After removing the two locking cams, eyebolts and Belleville washers, (which secure the blade frame to the rocker's swing shaft), the blade frame can be removed. The eyebolts and Belleville washers can be removed by turning them counter clockwise once the cams have been removed. See illustration below.

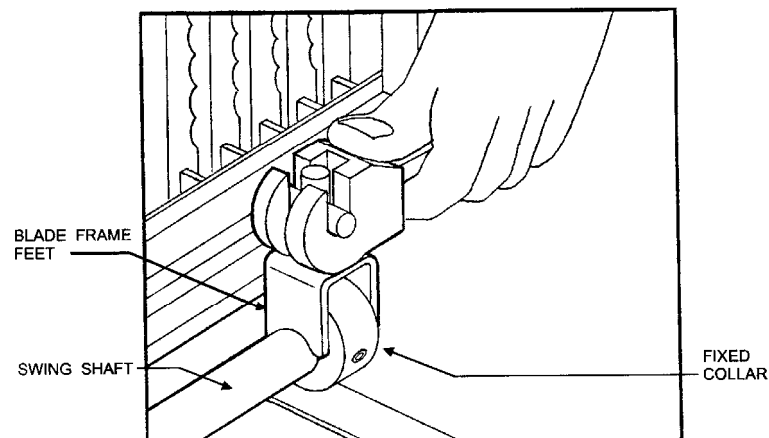



## 797-N BREAD SLICER

### Removing the Blade Frames (Continued)

## CAUTION

**THE BLADES ARE EXTREMELY SHARP.  
ALWAYS HANDLE BLADE FRAMES WITH CARE.**

The blade frame can now be carefully lifted from the slicer. See below.

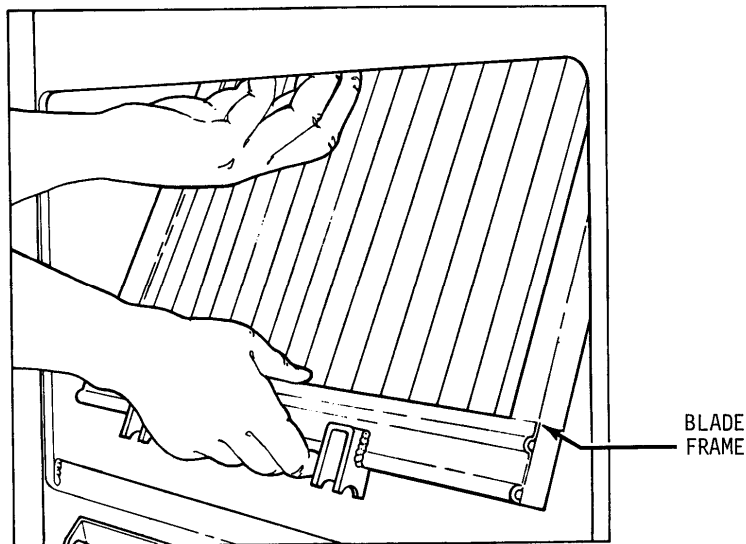

Removal of the infeed side blade frame is accomplished in a similar fashion. However the chute guard must first be removed by removing the four knobs which hold it in place this will allow access to the locking cams. See the illustration below.

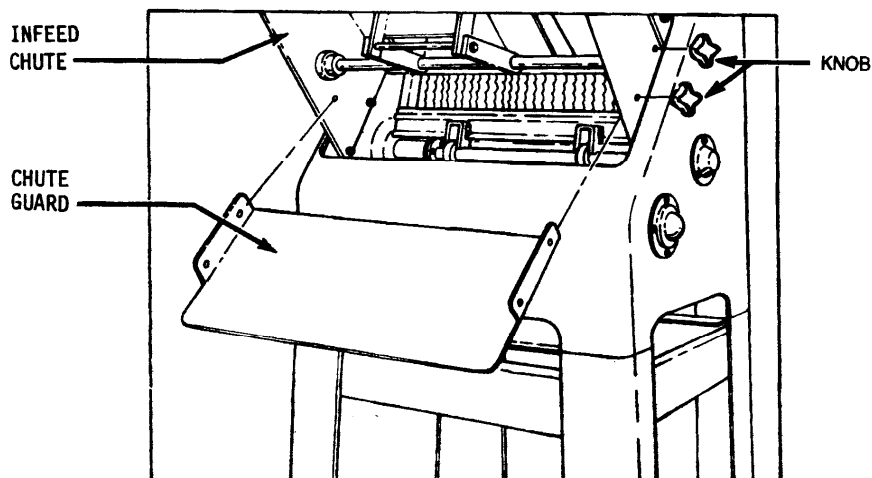



## 797-N BREAD SLICER

### *Removing the Blade Frames (Continued)*

Replacement of the blade frames is done by reversing the removal procedures. Ensure That the feet of the blade frames rest snugly on the swing shafts and that you have included the Belleville washers with the eye bolts.

### **NOTE**

**WHEN INSTALLING THE BELLEVILLE WASHERS, THEY MUST BE PLACED SO THAT THE CROWN IS UP AS SHOWN IN THE ILLUSTRATION BELOW.**

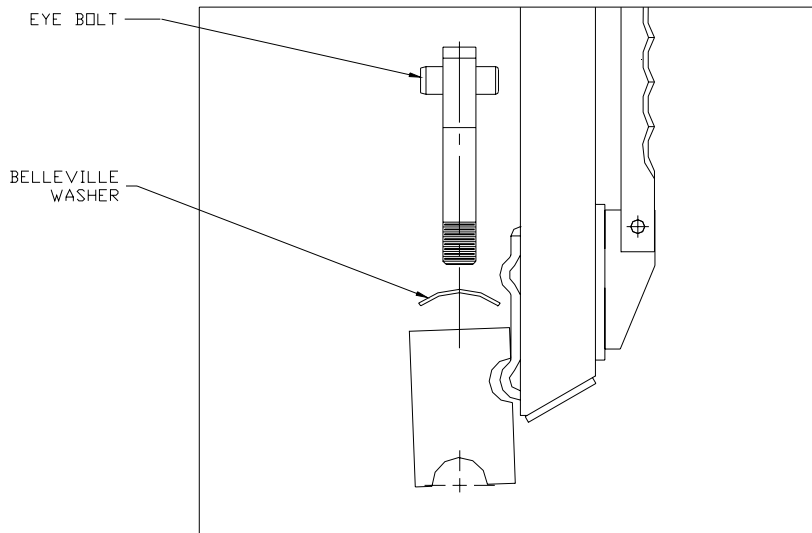

When replacing the eye bolts turn them clockwise until moderate pressure is required to close the cam. If the cam is too easy to close rotate the eye bolt a half turn more in the clockwise direction and try to reinstall the cam. Repeat these partial rotations until moderate pressure is required to close the cam. If the cams are either difficult or impossible to close, rotate the eye bolt a half turn in the counter clockwise direction. Repeat until the cams can be closed using moderate pressure.



---

---

## 797-N BREAD SLICER

---

---

### *Changing the Blades*

#### **WARNING**

**ALWAYS DISCONNECT THE SLICER FROM THE POWER SUPPLY BEFORE ATTEMPTING ANY TYPE OF MAINTENANCE TASK.**

#### **CAUTION**

**THE BLADES ARE EXTREMELY SHARP. ALWAYS HANDLE THEM WITH CARE.**

#### **NOTE**

**DO NOT INTERCHANGE THE TWO BLADE FRAMES. REPLACE THE BLADE FRAME TO THE SAME SIDE OF THE MACHINE AS IT WAS TAKEN FROM**

#### **NOTE**

**WHEN CHANGING BLADES FIRST NOTE THE DIRECTION THE SHARPENED EDGES ARE FACING ON THE BLADE FRAME. THEY ARE FACING UP ON ONE FRAME AND DOWN ON THE OTHER. DO NOT CHANGE THIS DIRECTION.**

Place the blade frame on a flat surface. You may use the special knife tool, shown in the illustration on the next page, or use a common set of pliers to depress the spring-loaded pin holding each knife. This will reduce the tension on the knife so that it may be easily removed.

In the illustration on the next page you can see the use of the knife tool. It is inserted into the blade frame on the spring-loaded pin end and then by lifting up on the tool it will deflect the pin reducing the tension on the knife. Once this has been done the knife can be carefully removed.



## 797-N BREAD SLICER

### Changing the Blades (Continued)

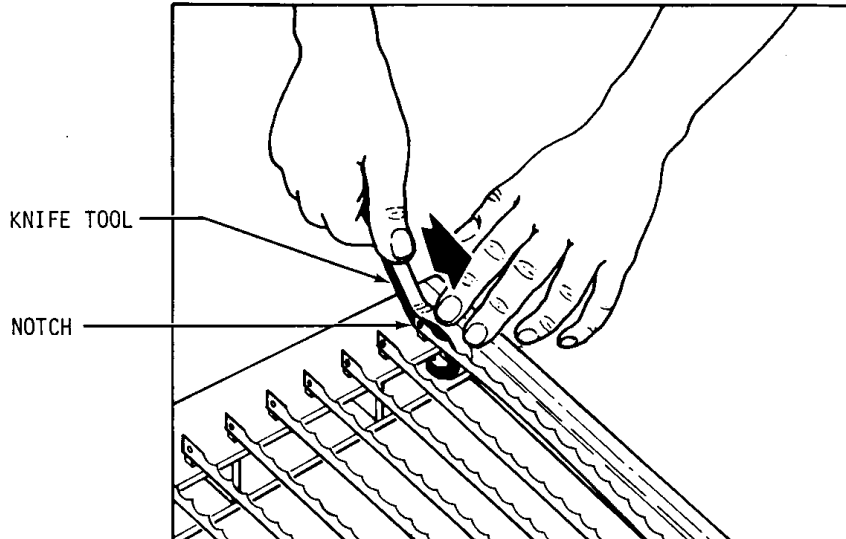

The new knife can be installed by reversing the removal procedure. A paper clip can be used to hold the knife in position on the lower pin to ease installation. See the illustration below.

### **NOTE**

**WHEN REPLACING ALL THE KNIVES, ALWAYS REMOVE THE CENTER KNIVES FIRST AND WORK TOWARD THE ENDS. INSTALL THE NEW KNIVES AT THE ENDS FIRST AND WORK ALTERNATELY TOWARD THE CENTER.**

### **CAUTION**

**NEVER PUT BLADE FRAMES IN THE SLICER WITHOUT KNIVES.**

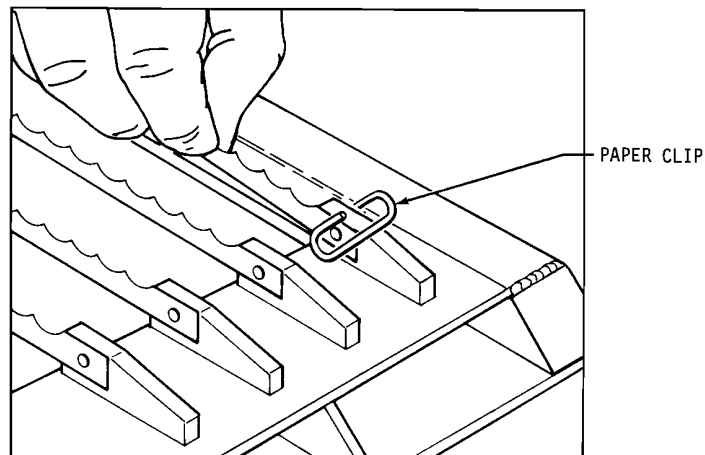



---

---

## 797-N BREAD SLICER

---

---

### *Tightening the Belt*

### **WARNING**

**ALWAYS DISCONNECT THE SLICER FROM THE POWER SUPPLY BEFORE ATTEMPTING ANY TYPE OF MAINTENANCE TASK.**

### **CAUTION**

**OVER-TIGHTENING THE DRIVE BELT  
MAY CAUSE BEARING OR MOTOR FAILURE.**

Remove the crumb tray from the slicer and swing out the discharge table. See the illustration below.

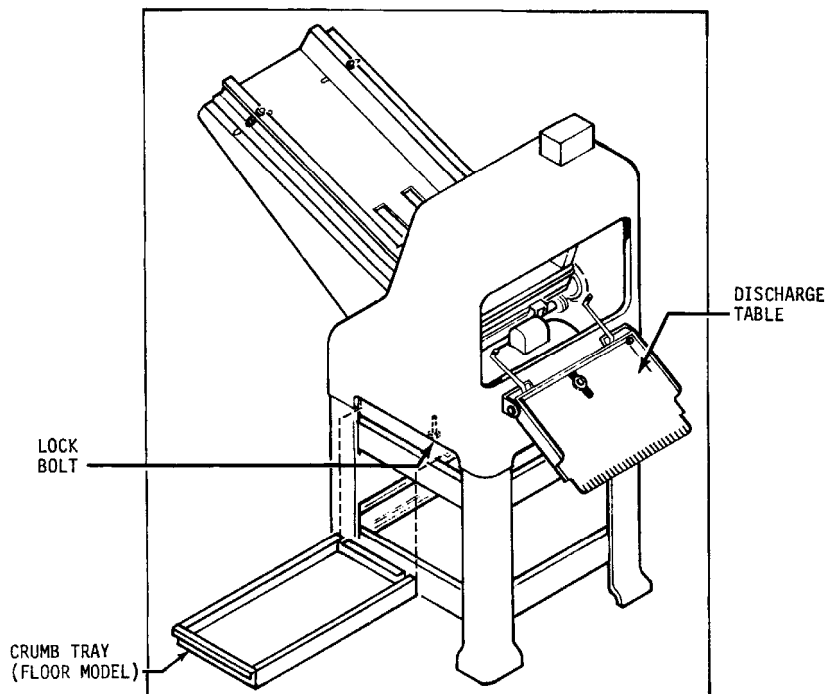

---

---

## 797-N BREAD SLICER

---

---

### *Tightening the Belt (Continued)*

Loosen the lockbolt located below the belt adjustment mechanism. See the next illustration. Locate the adjustment bolt below the belt and turn it counter clockwise with a wrench to increase tension on the belt or clockwise to reduce tension on the belt. The drive belt should be just tight enough that, using moderate finger pressure, it would deflect about 3/8 of an inch when pressed midway between the motor drive pulley and the driven pulley. Once the correct tension has been obtained retighten the lockbolt.

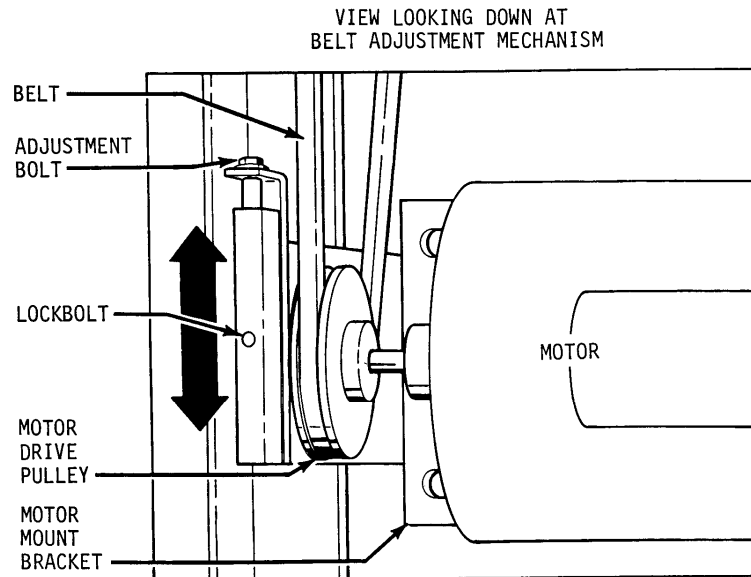



## 797-N BREAD SLICER

### Replacing the Belt

## **WARNING**

**ALWAYS DISCONNECT THE SLICER FROM THE POWER SUPPLY BEFORE ATTEMPTING ANY TYPE OF MAINTENANCE TASK.**

Referring to the “Tightening the Belt” section above, remove the crumb tray, swing out the discharge table, and reduce the tension on the belt by turning the adjusting bolt on the tightening mechanism clockwise until the belt can be slipped off from the motor pulley. Disconnect the end of the connecting rod at the rocker by removing the two capscrews and cap using a wrench. See the illustration below. The drive belt may now be removed from the machine. Installation of the new belt can be accomplished by reversing the removal procedures. Refer to the “Tightening the Belt” section when adjusting the drive belt tension.

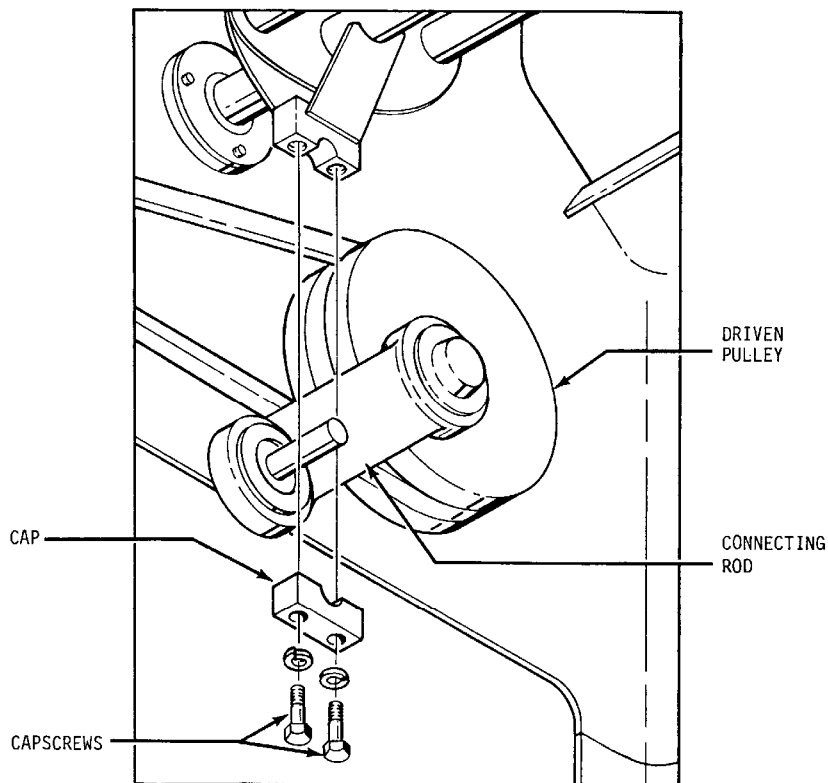



## 797-N BREAD SLICER

### *Adjusting the Blade Frames When Slices Vary in Thickness*

## **WARNING**

**ALWAYS DISCONNECT THE SLICER FROM THE POWER SUPPLY BEFORE ATTEMPTING ANY TYPE OF MAINTENANCE TASK.**

Swing out the discharge table of the slicer. Loosen, but do not remove the two locking cams, (clamps), which secure the blade frame to the swing shaft. Remove the plastic plug over the set screw in the fixed collar, see below. Using an allen wrench, loosen; but do not remove, the set screw in the fixed collar. Using a ruler, (15" maximum), measure the distance between the blades. Gently tap the collar with a small mallet either to the right or left until the distances between the blades is equal. When satisfied with the location tighten the fixed collar's set screw and replace the plastic plug. Lastly tighten the two locking cams which secure the blade frame.

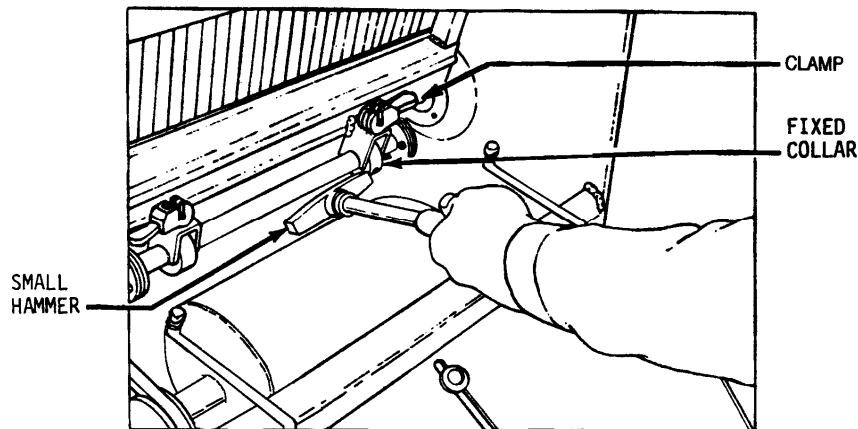



## 797-N BREAD SLICER

### *Adjusting the Clearance Between the Blade Frames*

## **WARNING**

**ALWAYS DISCONNECT THE SLICER FROM THE POWER SUPPLY BEFORE ATTEMPTING ANY TYPE OF MAINTENANCE TASK.**

The distance between the blade frames is adjusted by rotating the eccentric pins located above the blade frames. Two wrenches are used to do this. One wrench is used to keep the eccentric pin from rotating while the second is used to loosen the lock nut on the end of the pin. This nut secures the pin in position once its proper location is determined. See the illustration below.

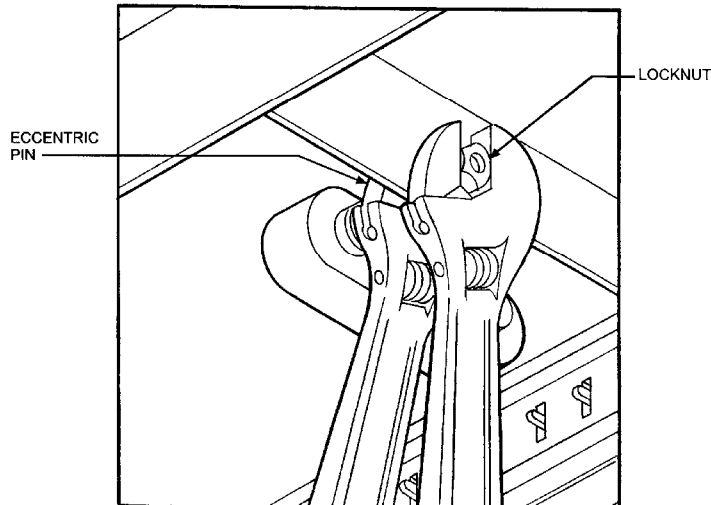

To adjust the eccentric, once the lock nut is loosened, rotate the pin using a wrench, rotating the pin, (it is possible that both pins will need adjustment at the same time), until the knives of the machine are in line, (alternating blades should not appear to be in front of or behind each other when viewed from the side). A straight edge may be used from the dull side of the knives to aid in determining if the knives are in line. When the eccentric pins are in the desired position tighten each of the locknuts to secure the position of the eccentrics. Check the blade frame clearance by turning the driven pulley by hand. Two things may happen if the knives are not inline, the blade frames may hit each other causing a loud knocking noise or the cutting efficiency of the machine may be greatly reduced.



---

---

## 797-N BREAD SLICER

---

---

### RECOMMENDED SPARE PARTS

<u>PART NUMBER</u>	<u>PART DESCRIPTION</u>	<u>NO. REQ'D</u>
5835-7705	Clip-Hairpin	2
0777-0034	Pin-Eccentric	2
0797-0059-2	Pin-STST Metric Blade Frame	2
0711-0002	Link-Top	2
5601-1966*	Belt-V (4L36-1/2) (60 Cycle Machines)	1
5709-1125*	Switch-Starter (1 Phase Machines)	1
5220-5001	Bearing-Driven Pulley (With Snap Ring)	1
5220-5040	Bearing-Driven Pulley	1
0797-0058-019	Stud-Driven Pulley	1
6904-6001	Gasket-Driven Pulley	1
0797-0071-4	Rod-Connecting	1
0797-0057-219	Stud-Swing	1
5220-4040	Bearing-Rocker Shaft	2
5220-0042	Bearing-Swing Shaft	4
6301-3609*	Motor-1/2 HP, 1-60-115/230	1
0797-0029-1	Knife-Type A	As Req'd.
0777-0970	Bolt-Eye	4
0777-0971	Cam-Clamp	4
5852-0050	Spring-Bellville	4

**\*For Other Electrics Contact the Factory**

For Service Parts Call Oliver Products @ 800-253-3893  
Rev. 2/12/09



## 797-N BREAD SLICER

### MAIN FRAME/ROCKER ASSEMBLY

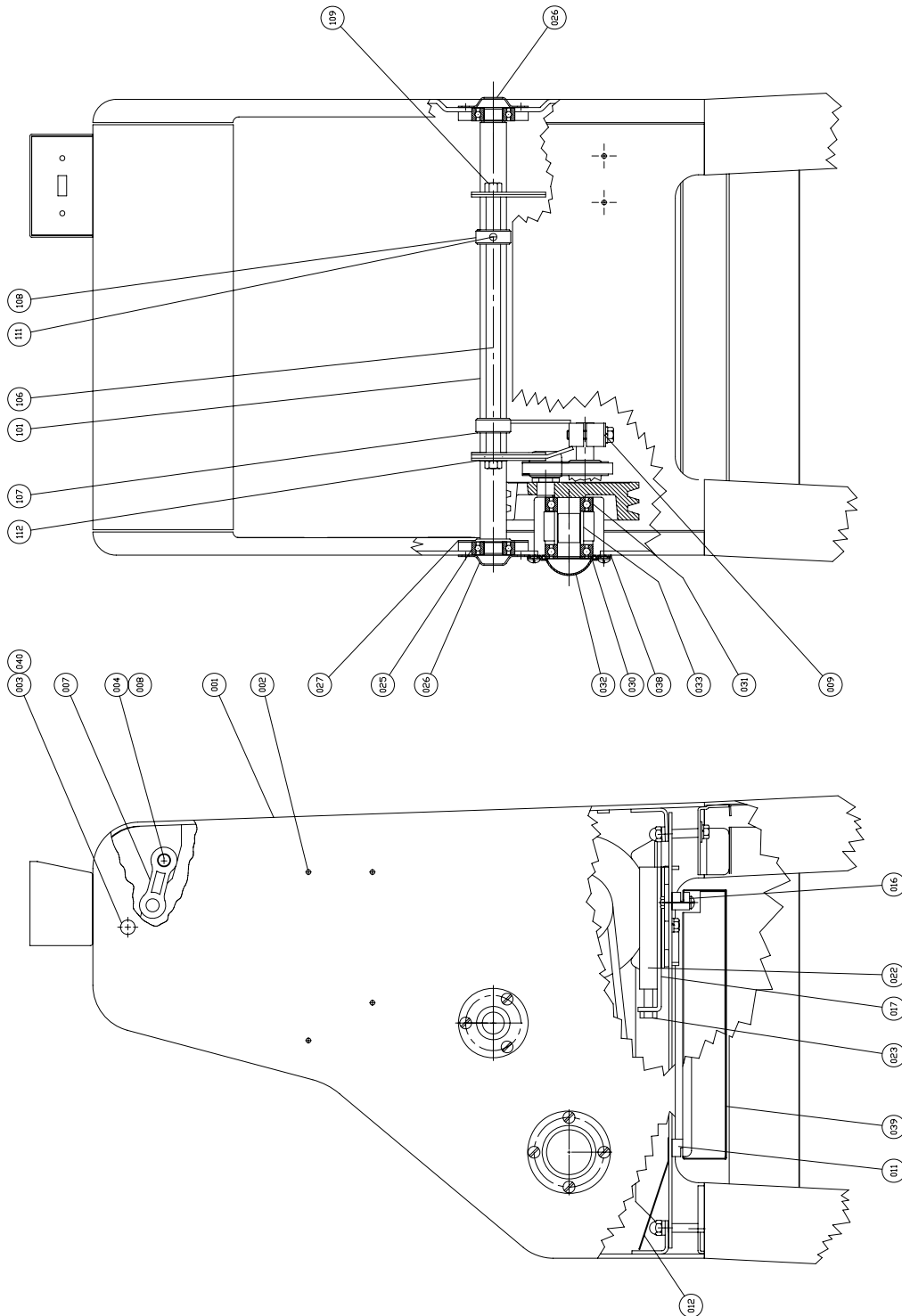

Rev 3/19/10



---

---

## 797-N BREAD SLICER

---

---

### MAIN FRAME/ROCKER PARTS LIST

<u>ITEM NO</u>	<u>PART DESCRIPTION</u>	<u>PART NUMBER</u>
001	FRAME-MAIN	0797-3000
002	PLUG-3/16 HOLE	5769-3000
003	PLUG-5/8 HOLE	5769-3005
004	PIN-ECCENTRIC	0777-0034
007	LINK-BLADE FRAME	0711-0002
008	CLIP-HAIRPIN	5835-7705
009	CLAMP-POWDER COAT WHITE	0730-0023
011	SLIDE-DRAWER	0797-0053
012	BAFFLE-CRUMB	0797-0117
016	SLIDE-DRAWER (NOTCHED)	0797-0053-004
017	BRACKET-MOTOR	0797-3420
022	CLAMP-MOTOR BRACKET	0797-3419
023	BOLT-SPECIAL	0797-3418
025	BEARING-BALL	5220-4040
026	CAP-BALL BEARING (OUTSIDE)	4090-0233-0023
027	CAP-BALL BEARING (INSIDE)	4090-0233-0044
030	RING-RETAINNG TRUARC	5840-1040
031	BEARING-BALL	5220-5040
032	CAP-BALL BEARING (DR PULLEY)	4090-0244-0005
038	GASKET-CORK	6904-6001
039	TRAY-EXTRA CAPACITY CRUMB	0797-3079
040	WASHER	0797-3471
101	ROCKER	0732-0012-001
106	SHAFT-SWING	0730-0024-001
107	COLLAR-HOLD DOWN	0797-0031-002
108	COLLAR-LOCATING	0797-0031-003
110	ROD-THREADED NYLON 3/8-16	5840-8076
111	SCREW-SOCKET SET 3/8-16 X 1/4	5842-6156
112	BEARING-BALL	5220-0042

FOR SERVICE PARTS CALL OLIVER PRODUCTS @ 800-253-3893  
Rev. 3/19/10



---

---

## 797-N BREAD SLICER

### BASE/CASTER ASSEMBLY

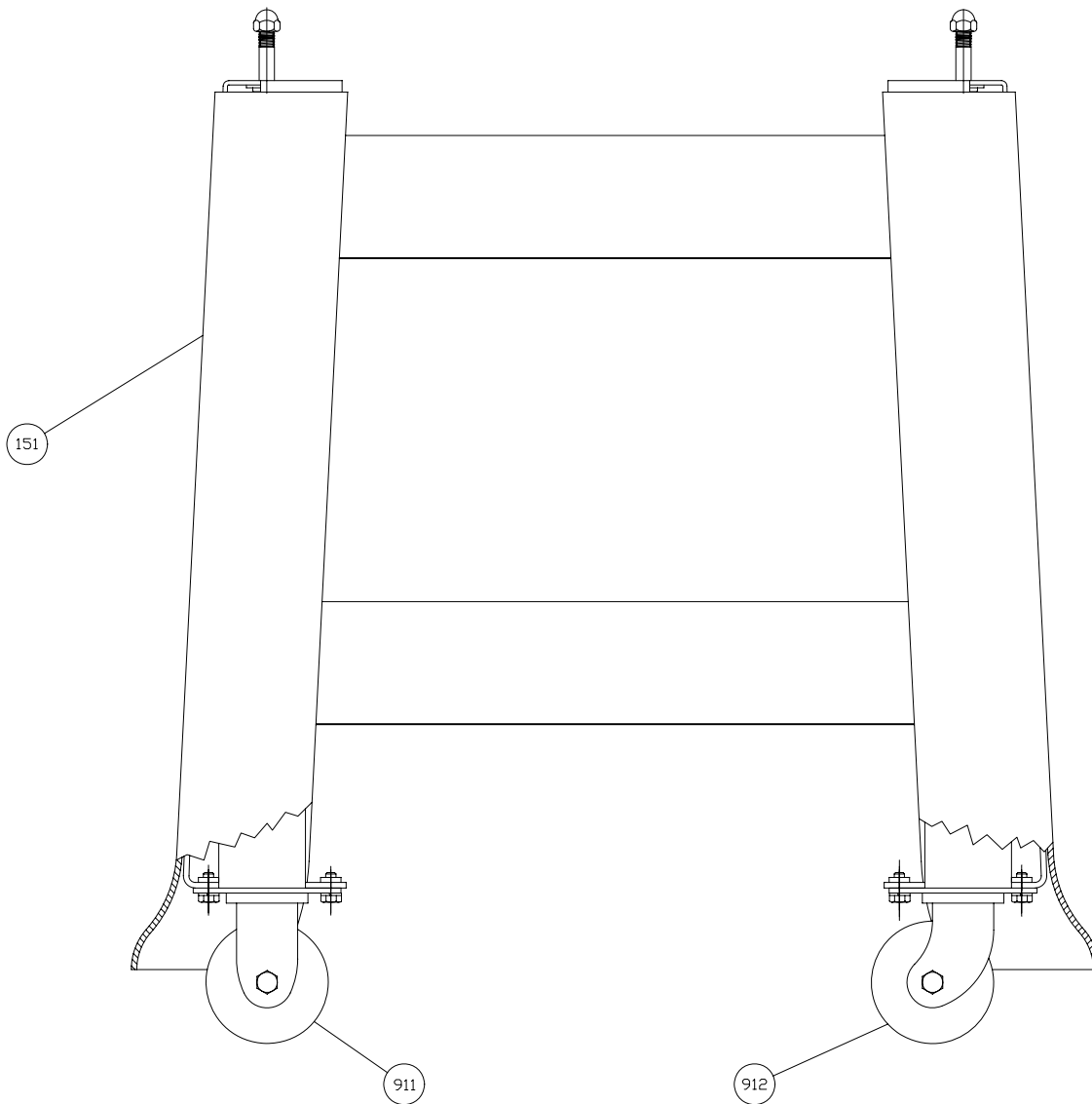



---

---

**797-N BREAD SLICER**

---

---

**BASE/CASTER PARTS LIST**

<b>ITEM NO</b>	<b>PART DESCRIPTION</b>	<b>PART NUMBER</b>
151	BASE-16" CASTER	0797-3068
911	CASTER-3" RIGID	5902-2363
912	CASTER-3" SWIVEL	5902-2364

FOR SERVICE PARTS CALL OLIVER PRODUCTS @ 800-253-3893



### 797-N BREAD SLICER

### SLICE PARTS/HOLDDOWN

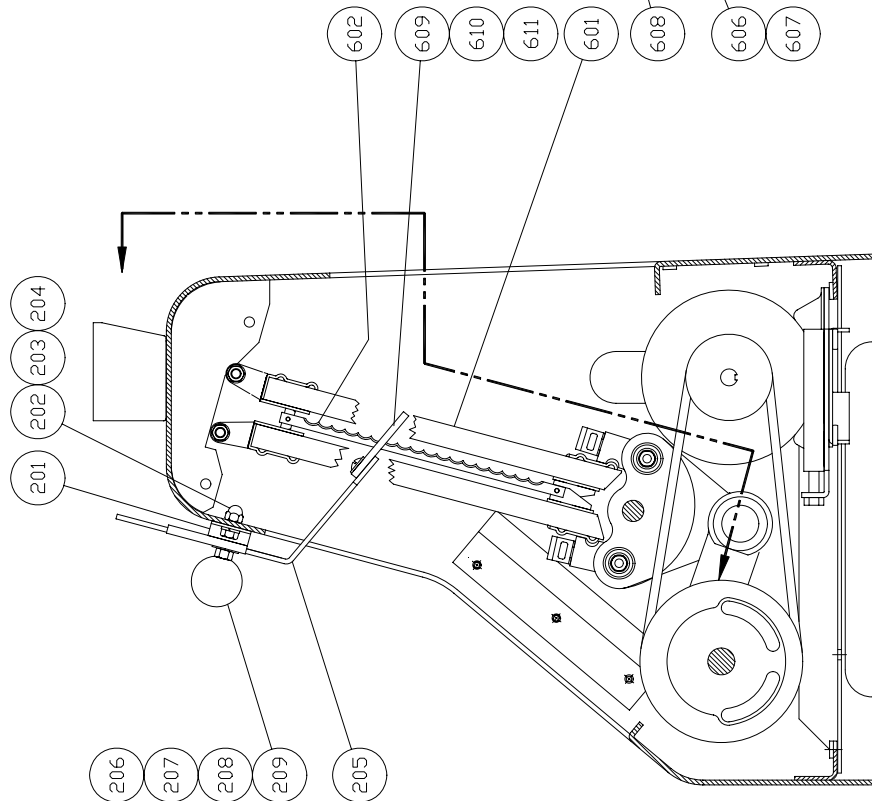
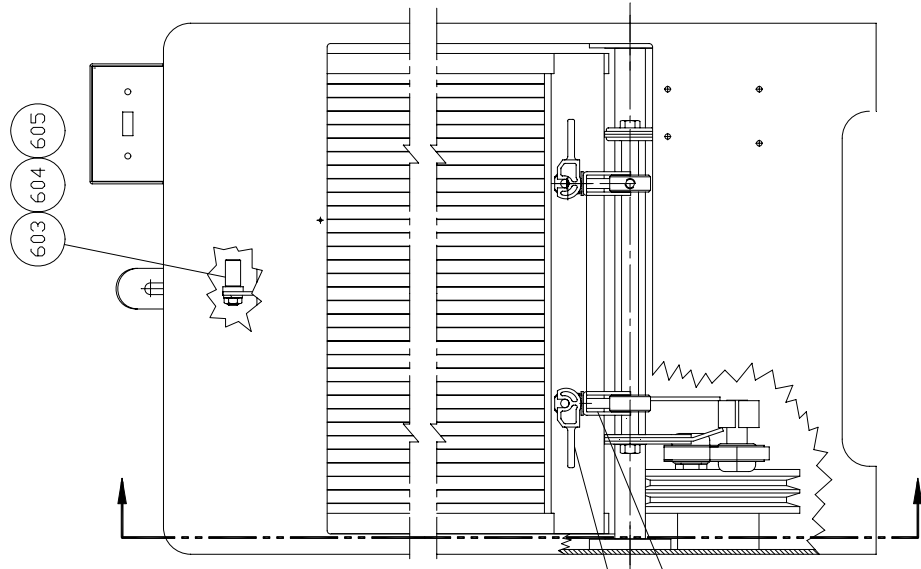

### ASSEMBLY



## 797-N BREAD SLICER

### SLICE PARTS/HOLDDOWN PARTS LIST

<u>ITEM NO</u>	<u>PART DESCRIPTION</u>	<u>PART NUMBER</u>
201	BRACKET-HOLDDOWN	0797-3012
205	HOLDDOWN	0797-0358-201
209	KNOB	5911-7001
601*	FRAME- STST BLADE	0797-0300-5XX
602	KNIFE-TYPE A	0797-0029-1
603	PIN-STST METRIC BLADE FRAME	0797-0059-2
606	BOLT-EYE	0777-0970
607	WASHER-BELLEVILLE SPRING	5852-0050
608	CAM	0777-0971
609*	GUIDE-KNIFE	0797-0092-0XX
612**	TOOL-BLADE CHANGING	0797-0183

\* Specify Slice Thickness

\*\* Not Shown on Drawing

FOR SERVICE PARTS CALL OLIVER PRODUCTS @ 800-253-3893

Rev. 8/2/04



## 797-N BREAD SLICER

### 32 INCH GRAVITY INFED CHUTE ASSEMBLY

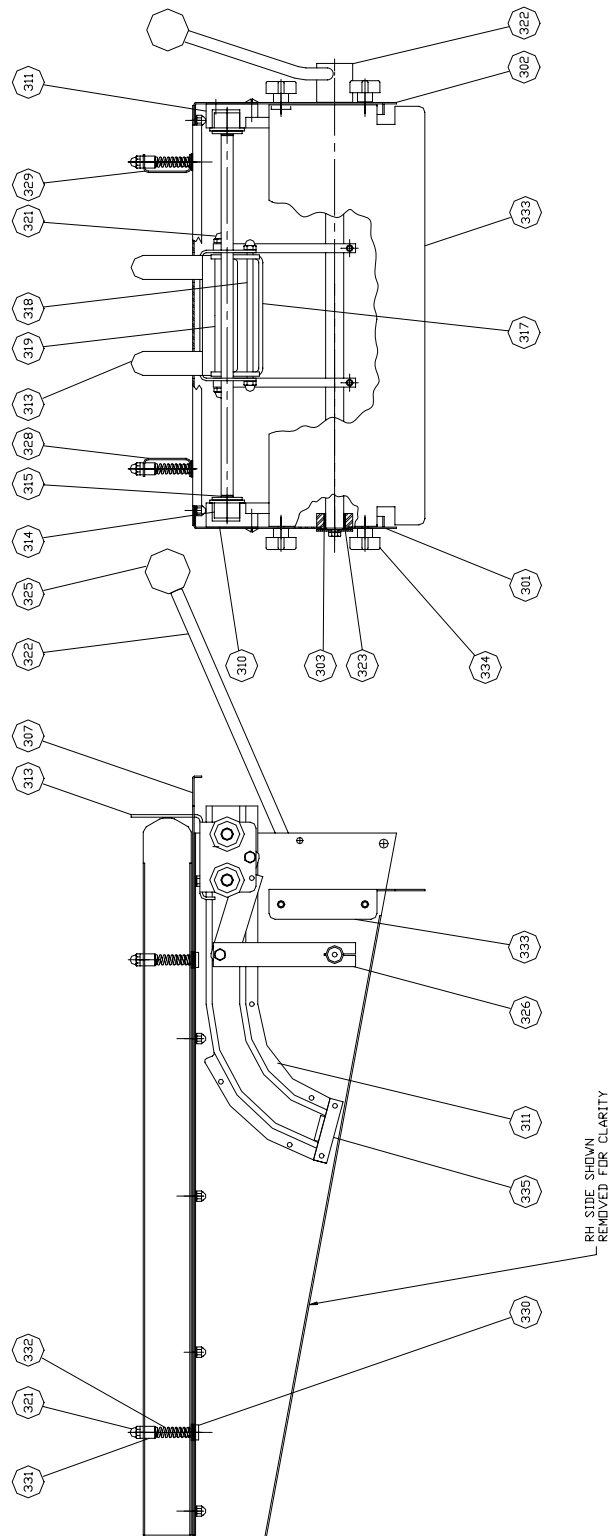



## 797-N BREAD SLICER

### 32 INCH GRAVITY INFEED CHUTE PARTS LIST

<u>ITEM NO</u>	<u>PART DESCRIPTION</u>	<u>PART NUMBER</u>
301	BRACE-RH 32" CHUTE	0797-3403-0001
302	BRACE-LH 32" CHUTE	0797-3403-0002
303	BEARING-BRONZE	5254-0300
307	TOP-32" GRAVITY CHUTE	0797-3404
310	TRACK-RH PUSHER	0797-3405-0001
311	TRACK-LH PUSHER	0797-3405-0002
313	CARRIAGE-PUSHER	0797-3406
314	WHEEL-CARRIAGE	0797-3407
315	RING-RETAINING	5840-2837
317	LINK	0797-3408
318	SHAFT-DE 6" LONG	0797-3409
319	SHAFT-DE 6-9/16" LONG	0797-3409-001
321	WASHER-NYLON	5851-8120
322	ASSEMBLY-SHAFT & LEVER	0797-3410
323	WASHER-SPECIAL	0797-3411
325	KNOB	5911-7002
326	BAR-PUSHER	0797-3412
328	GUIDE-RH 32" SIDE	0797-3413-0001
329	GUIDE-LH 32" SIDE	0797-3413-0002
330	PIN-SIDE GUIDE	0797-3414
331	SPACER	0797-3415
332	SPRING-COMPRESSION	7012-3107
333	GUARD-CHUTE	0797-3416
334	KNOB-W/STUD	4560-2508-1109
335	STOP	0797-3417

FOR SERVICE PARTS CALL OLIVER PRODUCTS @ 800-253-3893



---

---

**797-N BREAD SLICER**  
**48 INCH GRAVITY INFEED CHUTE ASSEMBLY**

---

---

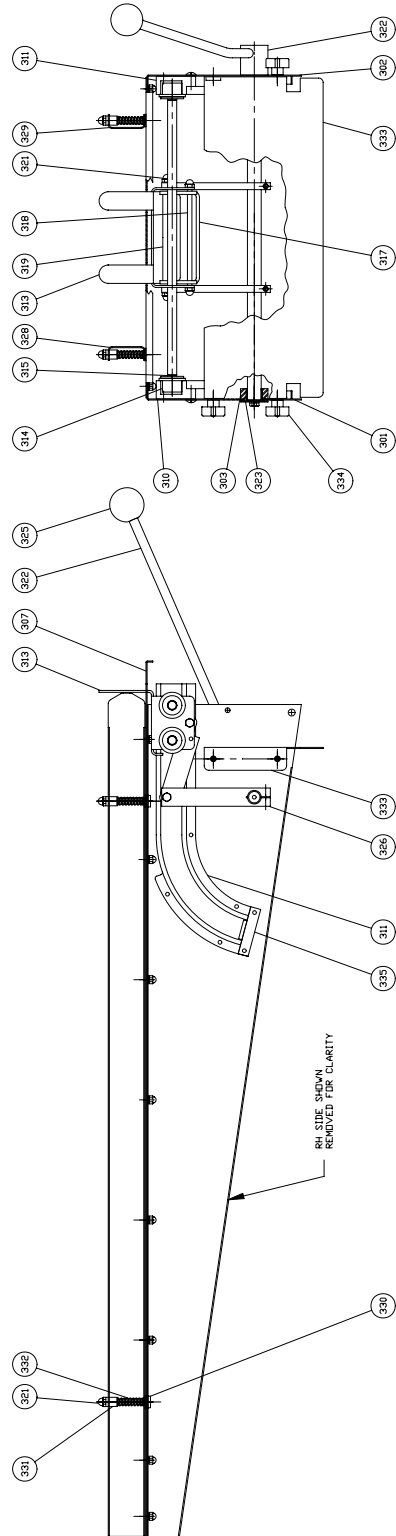



## 797-N BREAD SLICER

### 48 INCH GRAVITY INFEED CHUTE PARTS LIST

<b>ITEM NO</b>	<b>PART DESCRIPTION</b>	<b>PART NUMBER</b>
301	BRACE-RH 48" CHUTE	0797-3403-0011
302	BRACE-LH 48" CHUTE	0797-3403-0012
303	BEARING-BRONZE	5254-0300
307	TOP-48" GRAVITY CHUTE	0797-3404-001
310	TRACK-RH PUSHER	0797-3405-0001
311	TRACK-LH PUSHER	0797-3405-0002
313	CARRIAGE-PUSHER	0797-3406
314	WHEEL-CARRIAGE	0797-3407
315	RING-RETAINING	5840-2837
317	LINK	0797-3408
318	SHAFT-DE 6" LONG	0797-3409
319	SHAFT-DE 6-9/16" LONG	0797-3409-001
321	WASHER-NYLON	5851-8120
322	ASSEMBLY-SHAFT & LEVER	0797-3410
323	WASHER-SPECIAL	0797-3411
325	KNOB	5911-7002
326	BAR-PUSHER	0797-3412
328	GUIDE-RH 48" SIDE	0797-3413-0011
329	GUIDE-LH 48" SIDE	0797-3413-0012
330	PIN-SIDE GUIDE	0797-3414
331	SPACER	0797-3415
332	SPRING-COMPRESSION	7012-3107
333	GUARD-CHUTE	0797-3416
334	KNOB-W/STUD	4560-2508-1109
335	STOP	0797-3417

FOR SERVICE PARTS CALL OLIVER PRODUCTS @ 800-253-3893



### 797-N BREAD SLICER

## 32 INCH COMBINATION INFEEED CHUTE ASSEMBLY

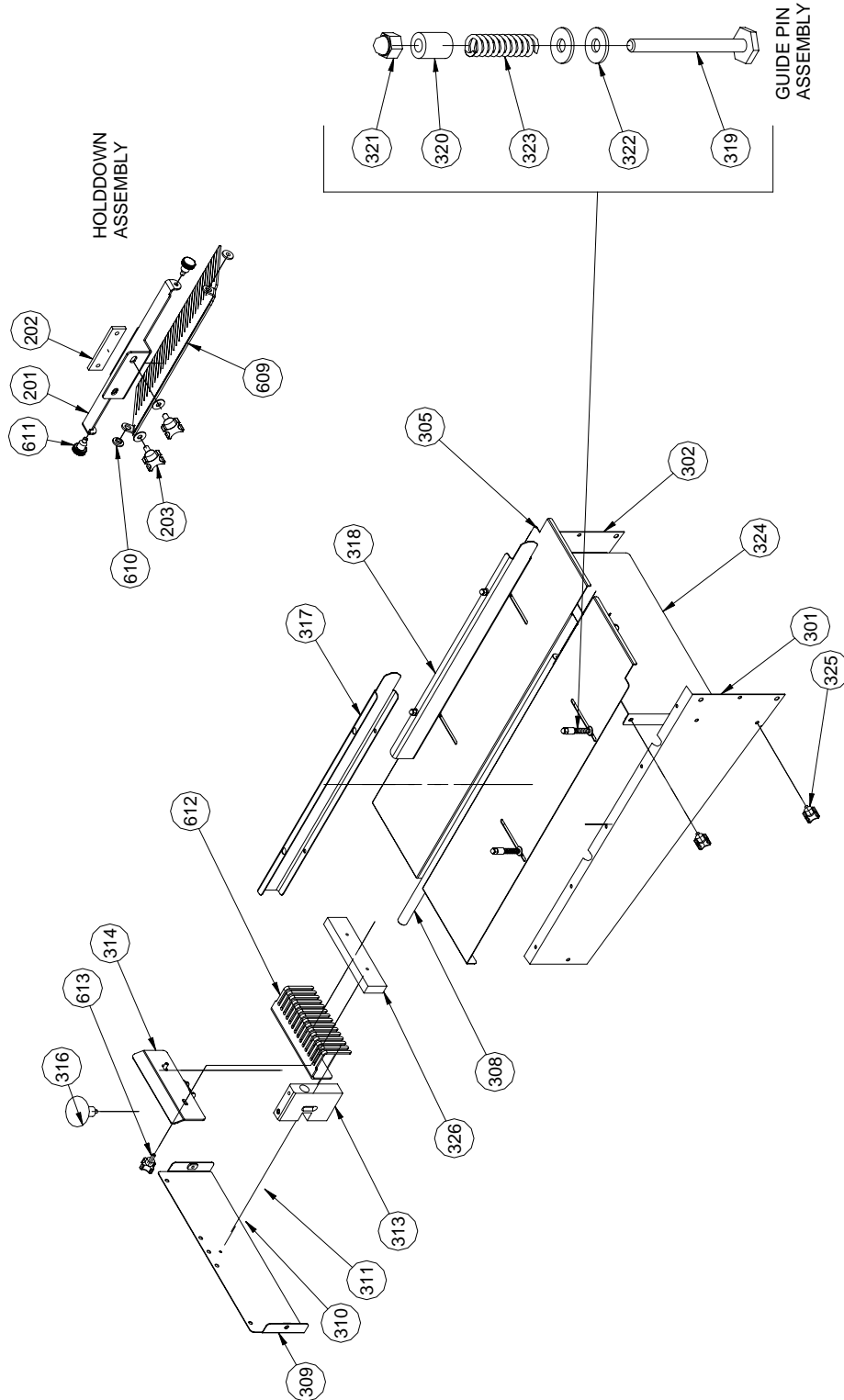

Rev. 1-20-04



## 797-N BREAD SLICER

### 32 INCH COMBINATION INFEED CHUTE PARTS LIST

ITEM NO	PART DESCRIPTION	PART NUMBER
201	BRACKET-HOLDDWON	0797-3441-1
202	NUTBAR 3/8-16	0797-3440
203	SCREW-CLAMP	4560-2512-1113
301	BRACE-RH 32" COMBI CHUTE	0797-3429-0001
302	BRACE-LH 32" COMBI CHUTE	0797-3429-0002
305	TOP-32" COMBI CHUTE	0797-3430
308	ROD-32" PUSHER GUIDE	0797-3431
309	COVER-END	0797-3432
310	CLIP-SPRING	5902-9007
313	BLOCK-PUSHER GUIDE	0797-3433-002
314	PLATE-PUSHER MTG	0797-3434
316	KNOB-OVAL	5911-7121
317	GUIDE-RH 32" COMBI SIDE	0797-3436-0001
318	GUIDE-LH 32" COMBI SIDE	0797-3436-0002
319	PIN-SIDE GUIDE	0797-3414
320	SPACER	0797-3415
321	NUT-ACORN	5832-0590
322	WASHER-NYLON	5851-8120
323	SPRING-COMPRESSION	7012-3107
324	GUARD-CHUTE	0797-3437
325	KNOB-W/STUD 1/4-20	4560-2508-1109
326	WEIGHT – 8"	0797-3438
326	WEIGHT – 14"	0797-3438-001
609*	HOLDDOWN	0797-3442-1XX
610	BUSHING	0777-0065
611	SCREW-CLAMP 3/8-16	4560-2512-1106
612*	PUSHER – 8" COMBI	0797-3435-0XX
612*	PUSHER – 14" COMBI	0797-3435-1XX
613	SCREW-CLAMP 1/4-20	4560-2508-1110

\* Specify Slice Thickness

FOR SERVICE PARTS CALL OLIVER PRODUCTS @ 800-253-3893

Rev. 8/26/05



### 797-N BREAD SLICER

#### STANDARD OUTFEED ASSEMBLY

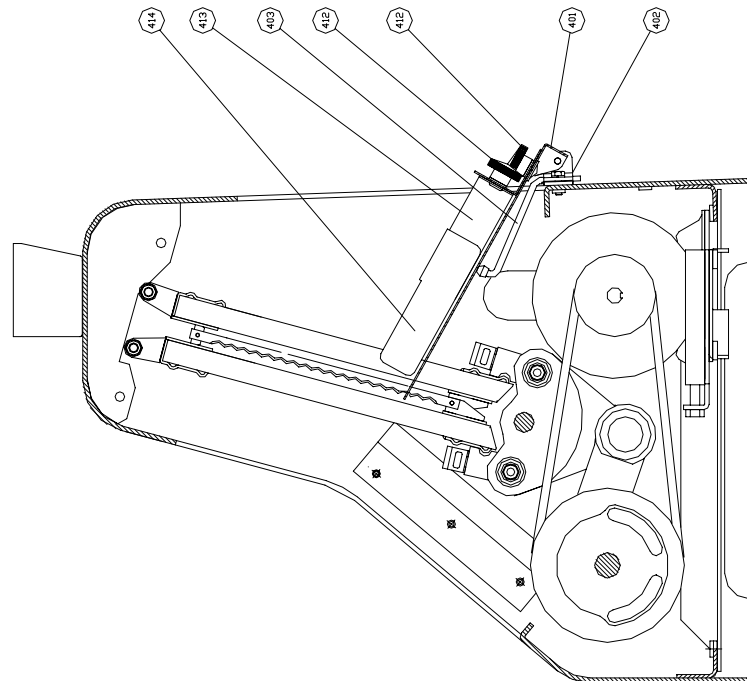
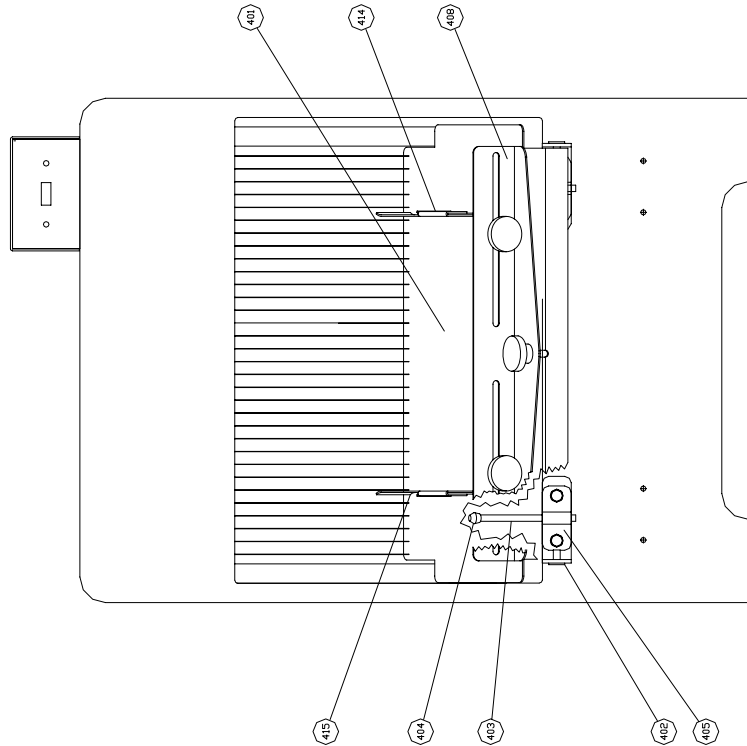

Rev 9-6-02



---

---

## 797-N BREAD SLICER

---

---

### STANDARD OUTFEED PARTS LIST

<b>ITEM NO</b>	<b>PART DESCRIPTION</b>	<b>PART NUMBER</b>
401*	TABLE-STANDARD OUTFEED	0797-3421-0XX
402	BRACKET-OUTFEED TABLE	0797-3422
403	ROD-STOP	0797-3423
404	CAP-NEOPRENE	5106-8920
405	CLAMP	0797-3424
408	STOP-BREAD	0797-0141
412	KNOB	5911-7000
413	GUIDE-BREAD	0797-0284
414	EXTENSION-RH GUIDE	0797-0285-0001
415	EXTENSION-LH GUIDE	0797-0285-0002

\* Specify Slice Thickness

FOR SERVICE PARTS CALL OLIVER PRODUCTS @ 800-253-3893  
Rev 9-6-02



## 797-N BREAD SLICER

### DRIVEN PULLEY ASSEMBLY

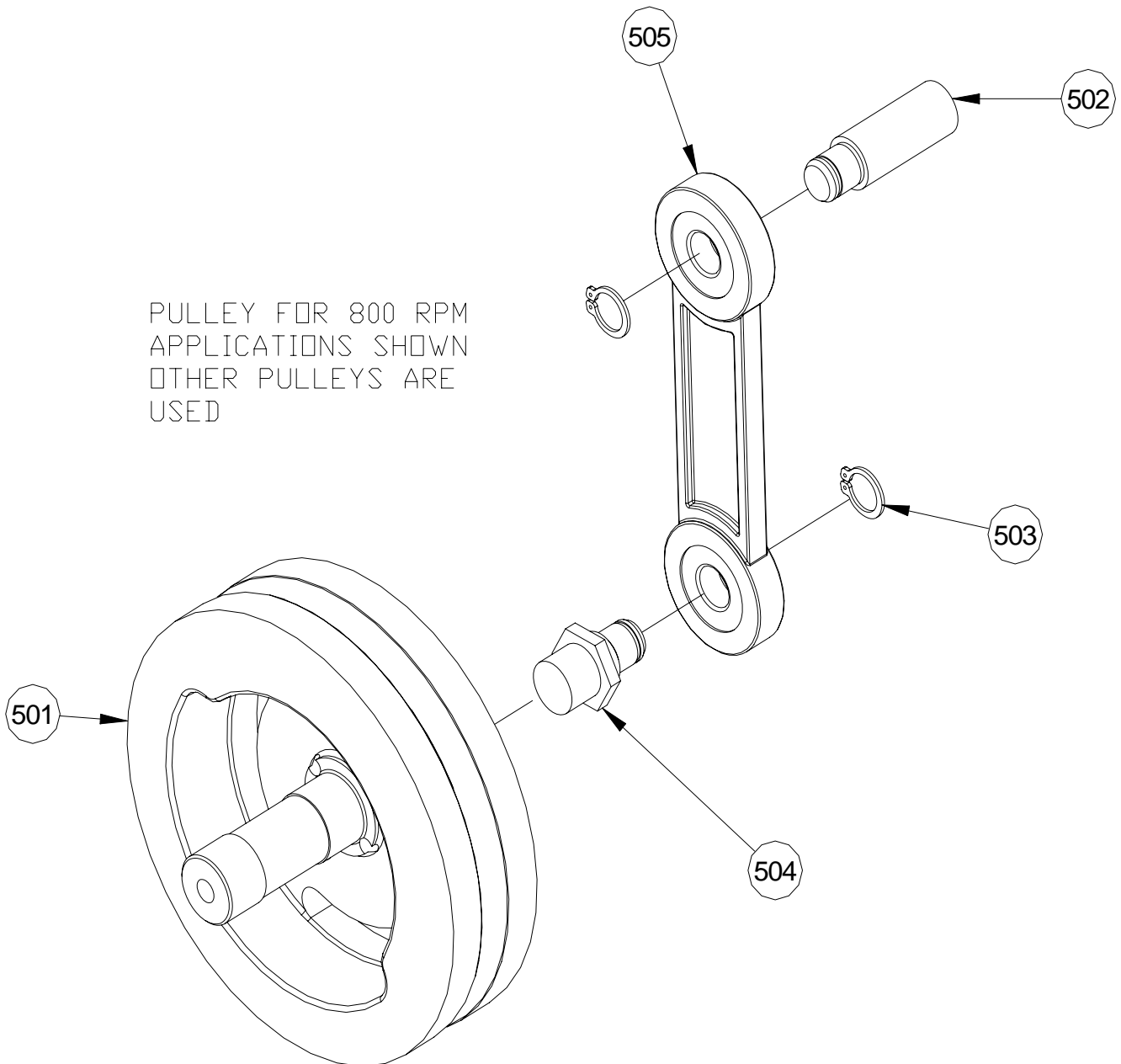

REV 1/24/08



Oliver Packaging & Equipment Company  
511 Sixth Street NW • Grand Rapids, MI 49504

(800) 253-3893  
www.oliverquality.com

---

---

## 797-N BREAD SLICER

---

---

### DRIVEN PULLEY PARTS LIST

<b>ITEM NO</b>	<b>PART DESCRIPTION</b>	<b>PART NUMBER</b>
501	PULLEY (32" CHUTES)	0730-0005-001
501	PULLEY (48" CHUTES)	0797-3370-001
502	STUD-SWING	0797-0057-219
503	RING-RETAINING	5840-2825
504	STUD	0797-0058-019
505	ROD-CONNECTING	0797-0071-4

FOR SERVICE PARTS CALL OLIVER PRODUCTS @ 800-253-3893  
REV. 2-12-09



## 797-N BREAD SLICER SINGLE PHASE ELECTRICAL

### Wiring Diagram (Single Phase)

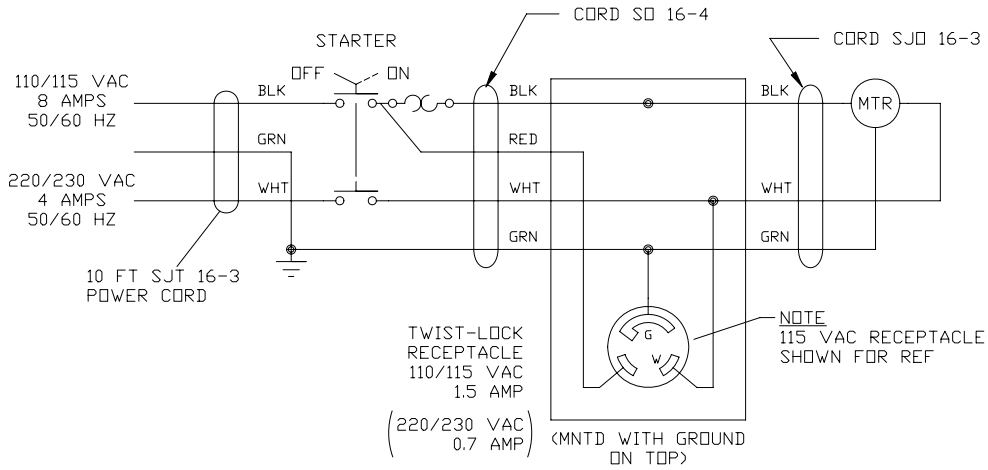

### Single Phase Electrical Assembly Drawing

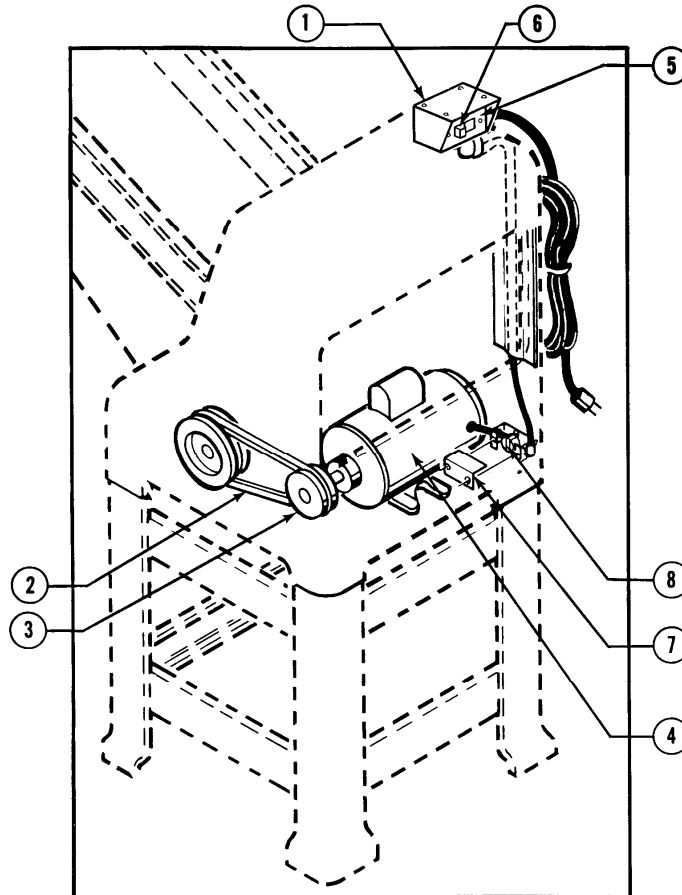

Rev. 9-6-02



### 797-N BREAD SLICER

#### Parts List 1/2 HP, 115 VAC, 60 Hertz, 1 Phase

<u>ITEM NO</u>	<u>PART DESCRIPTION</u>	<u>PART NUMBER</u>
1	ENCLOSURE-SWITCH	0797-3393-001
2	BELT-V (4L36-1/2)	5601-1966
3	PULLEY-MOTOR (32" CHUTES)	4575-7103-2001
3	PULLEY-MOTOR (48" CHUTES)	4575-7103-2004
4	MOTOR	6301-3609
5	COVER-SWITCH ENCLOSURE	0797-3394-001
6	SWITCH-STARTER	5709-1125
7	COVER-RECEPTACLE ENCLOSURE	0797-3385
8	RECEPTACLE-110/115 VAC	5769-0524

#### Parts List 1/2 HP, 230 VAC, 60 Hertz, 1 Phase

<u>ITEM NO</u>	<u>PART DESCRIPTION</u>	<u>PART NUMBER</u>
1	ENCLOSURE-SWITCH	0797-3393-001
2	BELT-V (4L36-1/2)	5601-1966
3	PULLEY-MOTOR (32" CHUTES)	4575-7103-2001
3	PULLEY-MOTOR (48" CHUTES)	4575-7103-2004
4	MOTOR	6301-3609
5	COVER-SWITCH ENCLOSURE	0797-3394-001
6	SWITCH-STARTER	5709-1125
7	COVER-RECEPTACLE ENCLOSURE	0797-3385
8	RECEPTACLE-220/230 VAC	5769-0523

#### Parts List 1/2 HP, 110 VAC, 50 Hertz, 1 Phase

<u>ITEM NO</u>	<u>PART DESCRIPTION</u>	<u>PART NUMBER</u>
1	ENCLOSURE-SWITCH	0797-3393-001
2	BELT-V (4L36-1/2) (32" CHUTES)	5601-1966
2	BELT-V (XDV48-380) (48" CHUTES)	5601-1969
3	PULLEY-MOTOR (32" CHUTES)	4575-7104-2002
3	PULLEY-MOTOR (48" CHUTES)	4575-7104-2005
4	MOTOR	6301-3940
5	COVER-SWITCH ENCLOSURE	0797-3394-001
6	SWITCH-STARTER	5709-1125
7	COVER-RECEPTACLE ENCLOSURE	0797-3385
8	RECEPTACLE-110/115 VAC	5769-0524

#### Parts List 1/2 HP, 220 VAC, 50 Hertz, 1 Phase

<u>ITEM NO</u>	<u>PART DESCRIPTION</u>	<u>PART NUMBER</u>
1	ENCLOSURE-SWITCH	0797-3393-001
2	BELT-V (4L36-1/2) (32" CHUTES)	5601-1966
2	BELT-V (XDV48-380) (48" CHUTES)	5601-1969
3	PULLEY-MOTOR (32" CHUTES)	4575-7104-2002
3	PULLEY-MOTOR (48" CHUTES)	4575-7104-2005
4	MOTOR	6301-3940
5	COVER-SWITCH ENCLOSURE	0797-3394-001
6	SWITCH-STARTER	5709-1125
7	COVER-RECEPTACLE ENCLOSURE	0797-3385
8	RECEPTACLE-220/230 VAC	5769-0523

Rev. 10-13-04

For Service Parts Call Oliver Products @ 800-253-3893



## 797-N BREAD SLICER THREE PHASE ELECTRICAL

### Wiring Diagram (Three Phase)

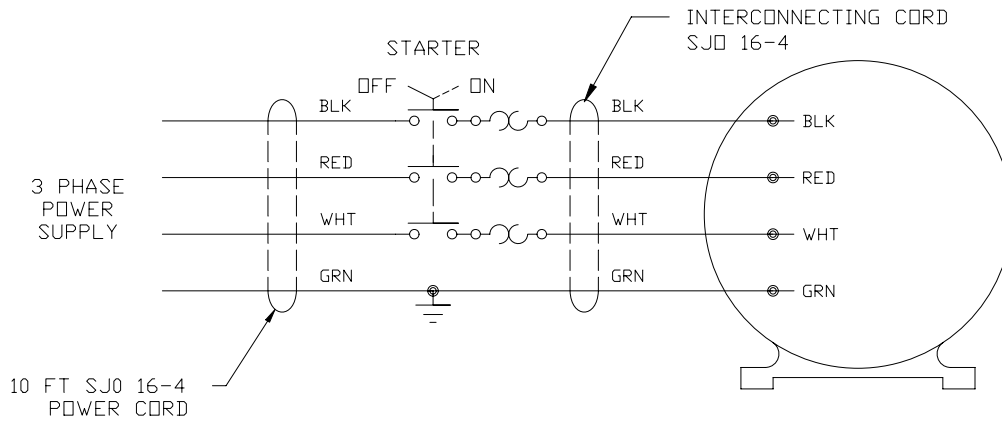

### Three Phase Electrical Assembly Drawing

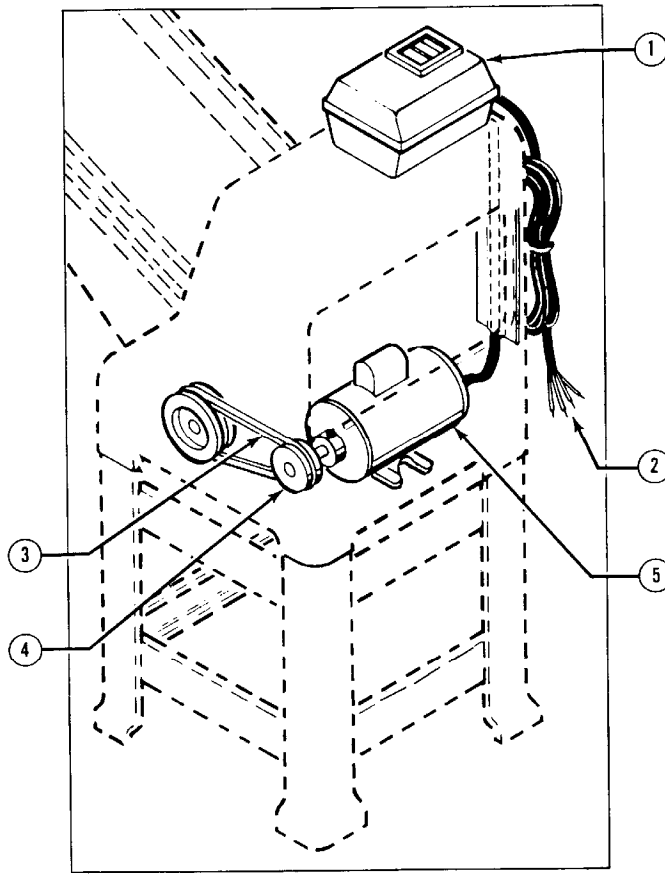

Rev. 9-6-02



### 797-N BREAD SLICER

#### Parts List 1/2 HP, 208 VAC, 60 Hertz, 3 Phase

<b>ITEM NO</b>	<b>PART DESCRIPTION</b>	<b>PART NUMBER</b>
1	STARTER	5709-3034
2	CORD-POWER	0797-3426
3	BELT-V (4L36-1/2)	5601-1966
4	PULLEY-MOTOR (32" CHUTES)	4575-7103-2001
4	PULLEY-MOTOR (48" CHUTES)	4575-7103-2004
5	MOTOR	6301-3811

#### Parts List 1/2 HP, 230/460 VAC, 60 Hertz, 3 Phase

<b>ITEM NO</b>	<b>PART DESCRIPTION</b>	<b>PART NUMBER</b>
1	STARTER	5709-3034
2	CORD-POWER	0797-3426
3	BELT-V (4L36-1/2)	5601-1966
4	PULLEY-MOTOR (32" CHUTES)	4575-7103-2001
4	PULLEY-MOTOR (48" CHUTES)	4575-7103-2004
5	MOTOR	6301-3800

#### Parts List 1/2 HP, 220 VAC, 50 Hertz, 3 Phase

<b>ITEM NO</b>	<b>PART DESCRIPTION</b>	<b>PART NUMBER</b>
1	STARTER	5709-3034
2	CORD-POWER	0797-3426
3	BELT-V (4L36-1/2) (32" CHUTES)	5601-1966
3	BELT-V (XDV48-380) (48" CHUTES)	5601-1969
4	PULLEY-MOTOR (32" CHUTES)	4575-7104-2002
4	PULLEY-MOTOR (48" CHUTES)	4575-7104-2005
5	MOTOR	6301-3811

#### Parts List 1/2 HP, 380 VAC, 50 Hertz, 3 Phase

<b>ITEM NO</b>	<b>PART DESCRIPTION</b>	<b>PART NUMBER</b>
1	STARTER	5709-3034
2	CORD-POWER	0797-3426
3	BELT-V (4L36-1/2) (32" CHUTES)	5601-1966
3	BELT-V (XDV48-380) (48" CHUTES)	5601-1969
4	PULLEY-MOTOR (32" CHUTES)	4575-7104-2002
4	PULLEY-MOTOR (48" CHUTES)	4575-7104-2005
5	MOTOR	6301-3975

For Service Parts Call Oliver Products @ 800-253-3893

Rev. 10-13-04

**THIS PAGE WAS INTENTIONALLY  
LEFT BLANK.**



## WARRANTY

### PARTS

Oliver Packaging & Equipment Company (Oliver) warrants that if any part of the equipment (other than a part not manufactured by Oliver) proves to be defective (as defined below) within one year after shipment, and if Buyer returns the defective part to Oliver within one year, Freight Prepaid to Oliver's plant in Grand Rapids, MI, then Oliver, shall, at Oliver's option, either repair or replace the defective part, at Oliver's expense.

### LABOR

Oliver further warrants that equipment properly installed in accordance with our special instructions, which proves to be defective in material or workmanship under normal use within one (1) year from installation or one (1) year and three (3) months from actual shipment date, whichever date comes first, will be repaired by Oliver or an Oliver Authorized Service Dealer, in accordance with Oliver's published Service Schedule.

For purposes of this warranty, a defective part or defective equipment is a part or equipment which is found by Oliver to have been defective in materials workmanship, if the defect materially impairs the value of the equipment to Buyer. Oliver has no obligation as to parts or components not manufactured by Oliver, but Oliver assigns to Buyer any warranties made to Oliver by the manufacturer thereof.

This warranty **does not** apply to:

1. Damage caused by shipping or accident.
2. Damage resulting from improper installation or alteration.
3. Equipment misused, abused, altered, not maintained on a regular basis, operated carelessly, or used in abnormal conditions.
4. Equipment used in conjunction with products of other manufacturers unless such use is approved by Oliver Products in writing.
5. Periodic maintenance of equipment, including but not limited to lubrication, replacement of wear items, and other adjustments required due to installation, set up, or normal wear.
6. Losses or damage resulting from malfunction.

The foregoing warranty is in lieu of all other warranties expressed or implied AND OLIVER MAKES NO WARRANTY OF MERCHANTABILITY OR FITNESS FOR PURPOSE REGARDING THE EQUIPMENT COVERED BY THIS WARRANTY. Oliver neither assumes nor authorizes any person to assume for it any other obligations or liability in connection with said equipment. OLIVER SHALL NOT BE LIABLE FOR LOSS OF TIME, INCONVENIENCE, COMMERCIAL LOSS, INCIDENTAL OR CONSEQUENTIAL DAMAGES.



Oliver Packaging & Equipment Company  
511 Sixth Street NW • Grand Rapids, MI 49504

(800) 253-3893  
[www.oliverquality.com](http://www.oliverquality.com)

## WARRANTY PROCEDURE

1. If a problem should occur, either the dealer or the end user must contact the Parts and Service Department and explain the problem.
2. The Parts and Service Manager will determine if the warranty will apply to this particular problem.
3. If the Parts and Service Manager approves, a Work Authorization Number will be generated, and the appropriate service agency will perform the service.
4. The service dealer will then complete an invoice and send it to the Parts and Service Department at Oliver Products Company.
5. The Parts and Service Manager of Oliver Packaging and Equipment Company will review the invoice and returned parts, if applicable, and approve for payment.



Oliver Packaging & Equipment Company  
511 Sixth Street NW • Grand Rapids, MI 49504

(800) 253-3893  
[www.oliverquality.com](http://www.oliverquality.com)

## RETURNED PARTS POLICY

This policy applies to all parts returned to the factory whether for warranted credit, replacement, repair or re-stocking.

Oliver Packaging and Equipment Company requires that the customer obtain a Return Material Authorization (RMA) number before returning any part. This number should appear on the shipping label and inside the shipping carton as well. All parts are to be returned prepaid. Following this procedure will insure prompt handling of all returned parts.

To obtain an RMA number contact the Repair Parts Department toll free at (800) 253-3893.

Parts returned for re-stocking are subject to a **RE-STOCKING CHARGE**.

Thank you for your cooperation,

Repair Parts Manager  
Oliver Packaging and Equipment Company