

Speedseal® MX 2

Key Features:

- Efficient, intermittent-motion sealing up to 27 packages/minute
- Adjustable speed
- Uses straight-slit film rolls
- Simple to operate; easy to cross-train employees
- Easy to clean
- Constructed of easy-to-clean stainless steel and anodized aluminum
- Removable tray carriers constructed of aluminum
- Supported by a nationwide service organization



Specifications:

- Weight: 340 lbs.
- Overall dimensions: W 23" x L 78" x H 47"
- Loading station = 3 - three compartment trays
- Maximum Tray Dimension: W 8.625" x L 6.5" x D 3.25"
- Electrical: 120 volts AC (USA), 6 AMPS, 60 Hz (USA)

Above specifications subject to change without notice.
The information contained herein is correct as of the date hereof.

Speedseal® MX 2

Specifications:

Weight:

340 lbs.

Tray Capacities:

8.625" (219mm) x 6.5" (165mm)

Film Lidding cut-off 7" or 3.5"

3.25" (82.5mm) depth

Temperature Range:

Factory set to approximately 275°F

Dimensions:

22.5" overall width

77" overall length

47" overall height

Electrics:

120 VAC (USA), 6 AMPS, Single Phase, 60 Hz (USA)

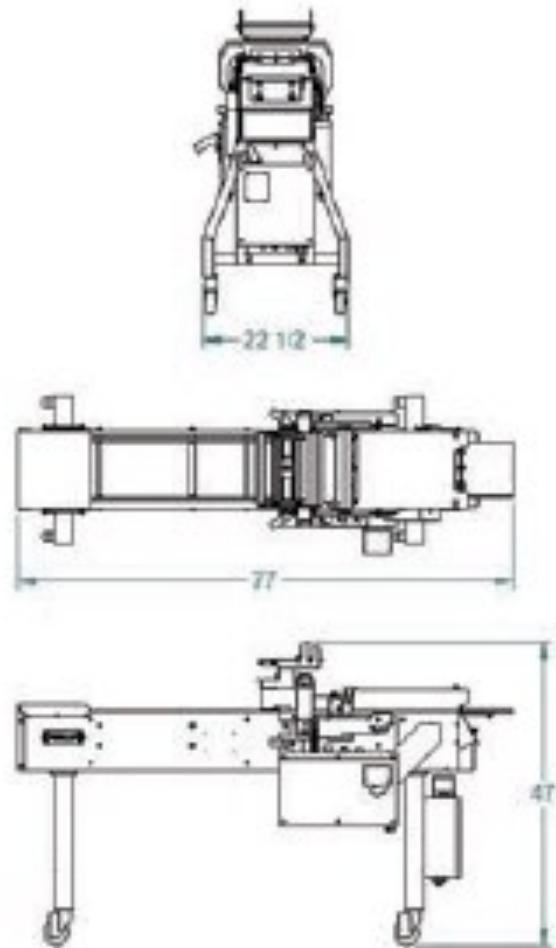

Above specifications subject to change without notice.
The information contained herein is correct as of the
date hereof.