



Grand Rapids, Michigan, U.S.A. 49504-5298

USER'S OPERATING AND INSTRUCTION MANUAL

MODEL 1179-S

BAGGER



1179S BAGGER

1179S OPERATORS MANUAL

INDEX

I. GENERAL

Safety Instructions	1179S20011
---------------------------	------------

II. OPERATION

Operation Instructions	1179S20004
Installing a Counter Weight	1179S20014
Field Installation Instructions	1179S20005
1179 Funnel Replacement	1179S20001

III. REPLACEMENT PARTS SECTION

1179S Parts List	1179S20006
1179S Exploded Parts Drawing	1179S20007

IV. BAG PURCHASING

Bag Specification Instructions	1279S20004
--------------------------------------	------------

V. WARRANTY SECTION

Warranty	GEN040225
Warranty Procedure	GEN040226
Returned Parts Policy	GEN040227

1179S BAGGER SAFETY INSTRUCTIONS

OLIVER PRODUCTS COMPANY

Every effort has been made by Oliver Products Company to provide you with a safe machine. It is essential, however, that machine operators and maintenance personnel observe the following safety instructions.

1. Before attempting to operate your bagger, read the Operating Instruction portion of this Manual.
2. Your Oliver 1179S Bagger must ONLY be connected to the special power supply outlet, furnished on the side of your Oliver Model #797-32, 797-48, or 797-PB Slicer for this purpose.
3. Make sure that the slicer is only connected to a properly grounded electrical supply source.
4. Make sure the machine has been disconnected from the power supply before cleaning or servicing.
5. Always keep hands away from moving parts.
6. Make sure that your machine has a correctly installed counter weight before use. (See Installation Instructions attached).

**FOR USE WITH
MODEL 797
SLICERS ONLY**

OPERATING INSTRUCTIONS FOR 1179S BAGGER

SPECIFICATIONS

MACHINE DIMENSIONS: 13" WIDE X 41" LONG X 13" HIGH
BAG WIDTH: 4 TO 13" (WICKETED BAGS ONLY)
BAG LENGTH: AS REQUIRED
STANDARD COLOR: WHITE
ELECTRICAL SERVICE: 115 VOLTS* , 50 OR 60 HZ, 1 ph, 1.02 AMP.
*** (230 VOLTS, .51 AMP. AVAILABLE)**

ACCESSORIES

- EXTRA LENGTH BAG TRAY
- BAG SUPPORT FOR TRAY
- SPECIAL HEIGHT FUNNELS

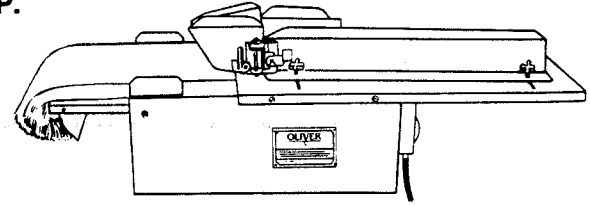

GENERAL:

The first three steps are concerned with adjusting an OLIVER SLICER for use with the bagger. Before making any adjustments always turn the slicer and bagger off and disconnect them from the power supply. The slicer and bagger must be adjusted for each change in product height, width or length. Each of these dimensions may also affect bag size. See your slicer operation manual for additional information and safety precautions.

ADJUSTMENTS:

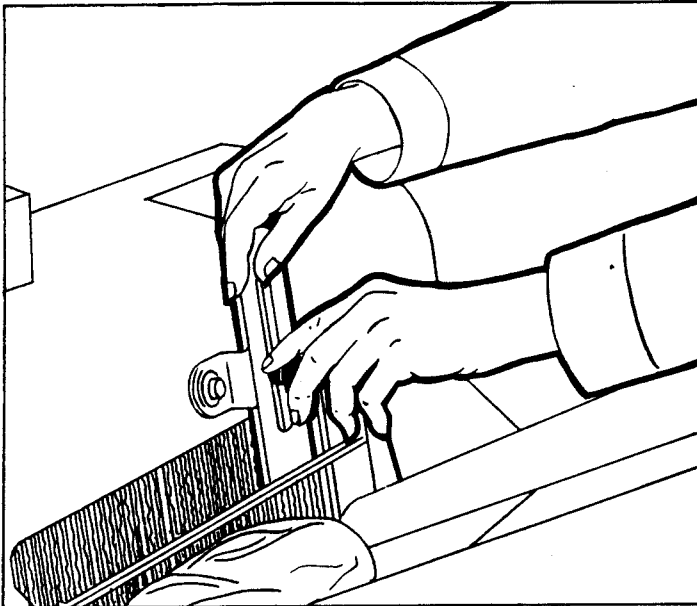

1. Start by adjusting the slicer for product height. The product should just clear the hold-down. The hold-down prevents the product from jumping as it passes thru the cutting knives.

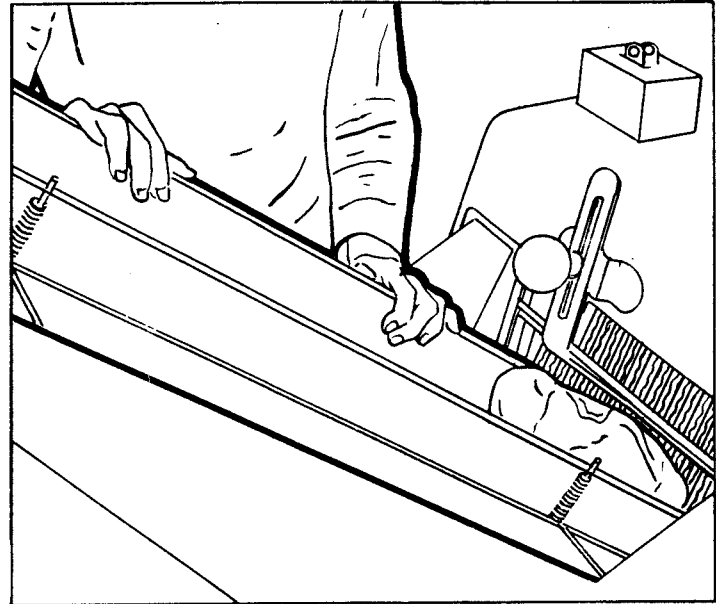

2. Using a typical product, adjust the infeed chute side guides by setting them approximately 1/8" wider than the product.

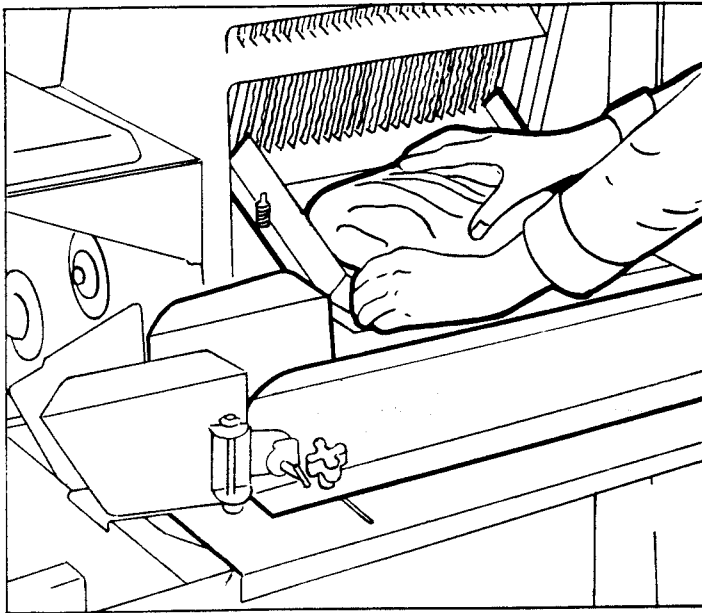

3. Adjust the outfeed side guides to coincide with the infeed guides, thus receiving the sliced loaf as it exits the blades. These guides will keep the end slices from tipping over.

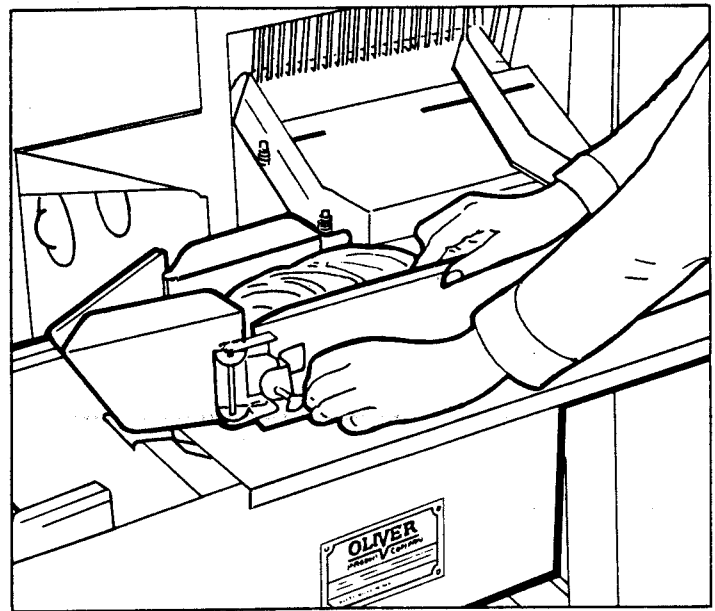

4. Center the loaf on the bagger and move the side guides into the product. When satisfied, tighten the knobs to maintain this position.

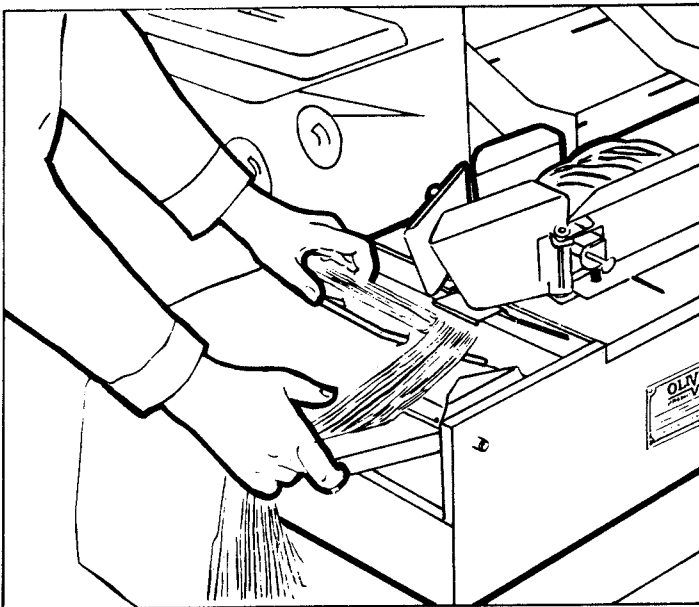

5. Wicketed bags must be used on your bagger. Place the wicket as shown with the wicket legs down and past the end of the bag tray.

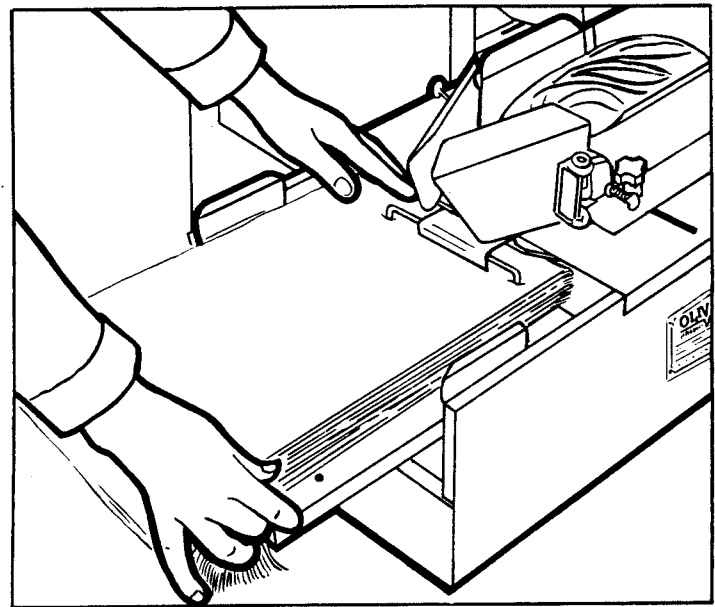

6. Secure the wicket behind the lip as shown.

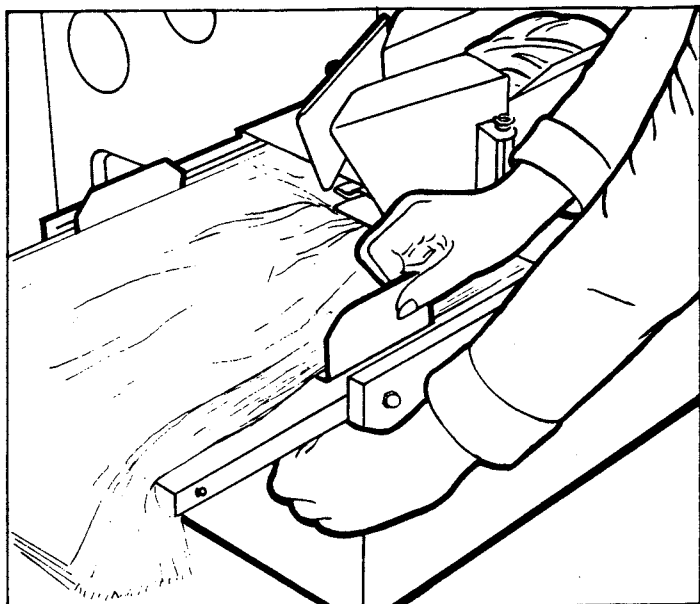

7. Adjust bag locaters so as to center the bags on the machine.

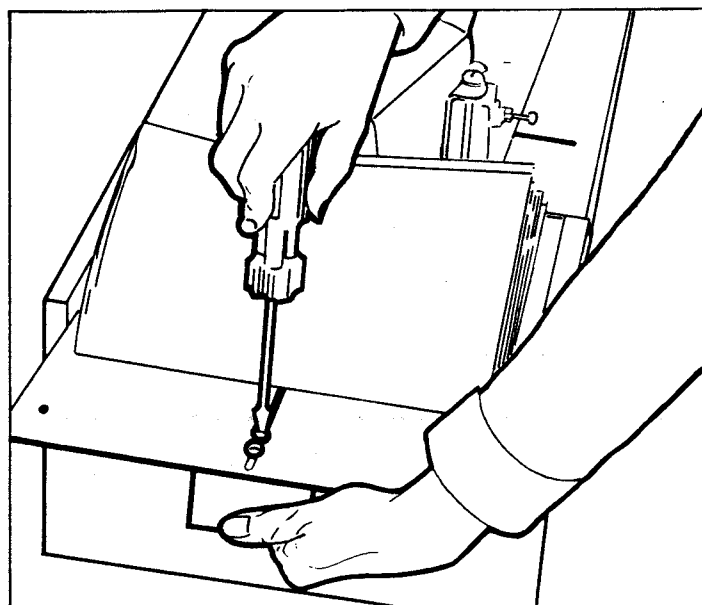

8. Adjust the weight so that it exerts enough force on the wicket to keep it from slipping out from under the lip.

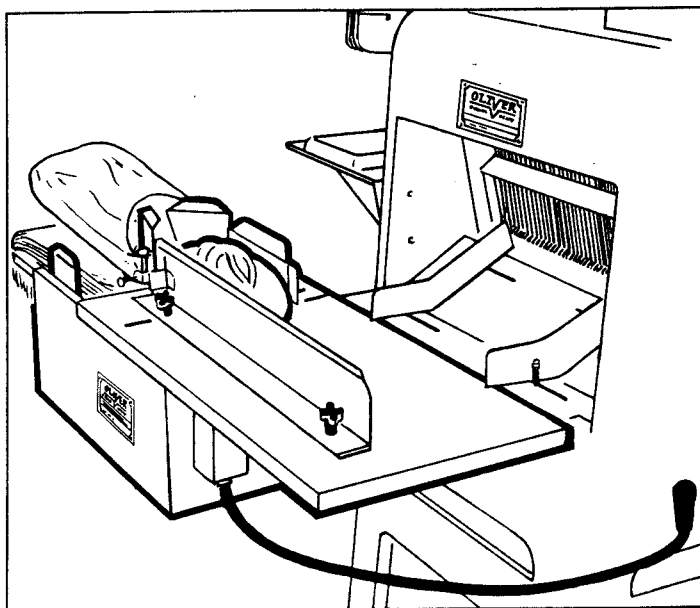

9. You are now ready to begin bagging. Reconnect the slicer to its power supply. Turn both machines on. The first bag should fill with air and become ready for loading. Check funnel entry for adequate clearance.

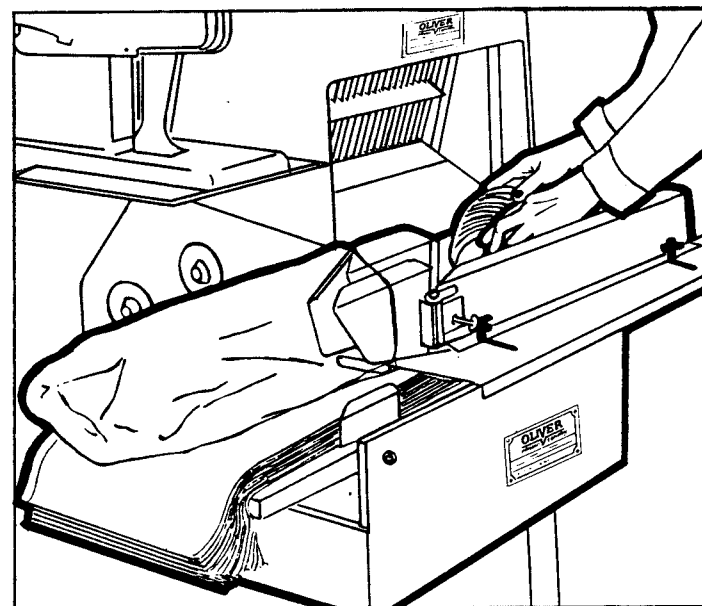

10. As sliced product exits the knives the operator should grasp the bread as shown. Remove it from the outfeed table and slide it into the bagger - - -

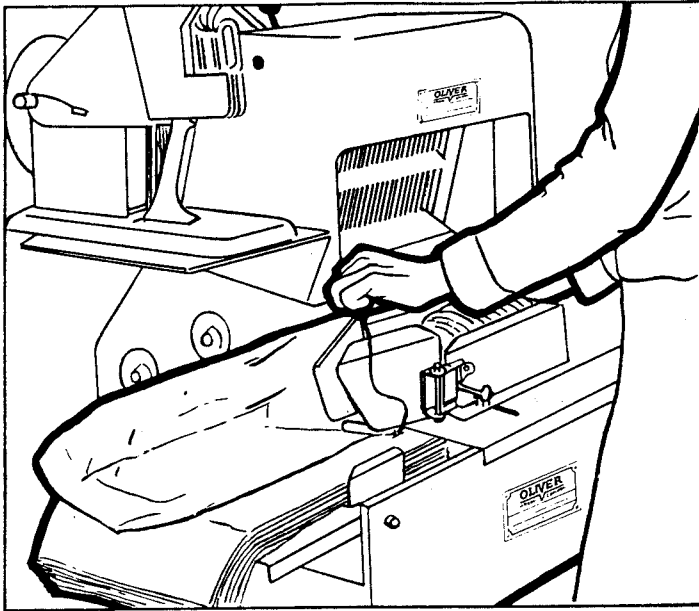

11. --- slide the product into the funnels. In certain cases it may help to hold the bag on its top edge as shown.

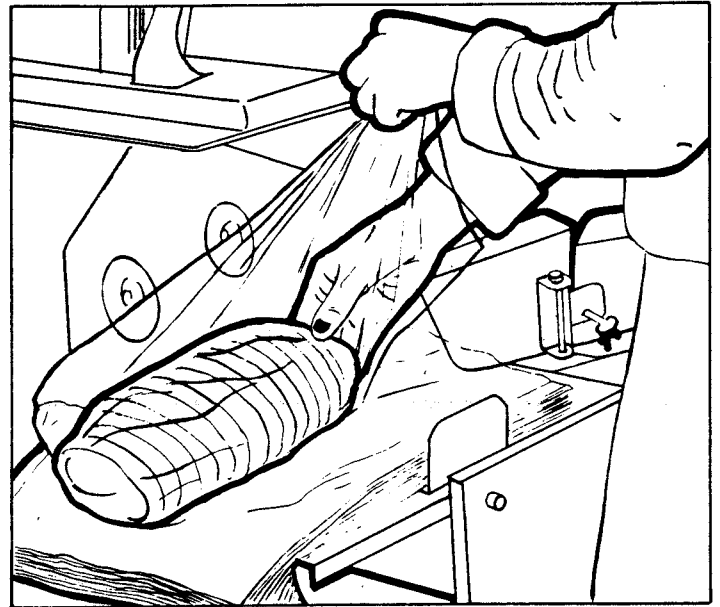

12. Push the product through the funnels and into the bag; continue pushing with one motion until the filled bag rips from the wicket. Steps 10-12 should be performed in one motion.

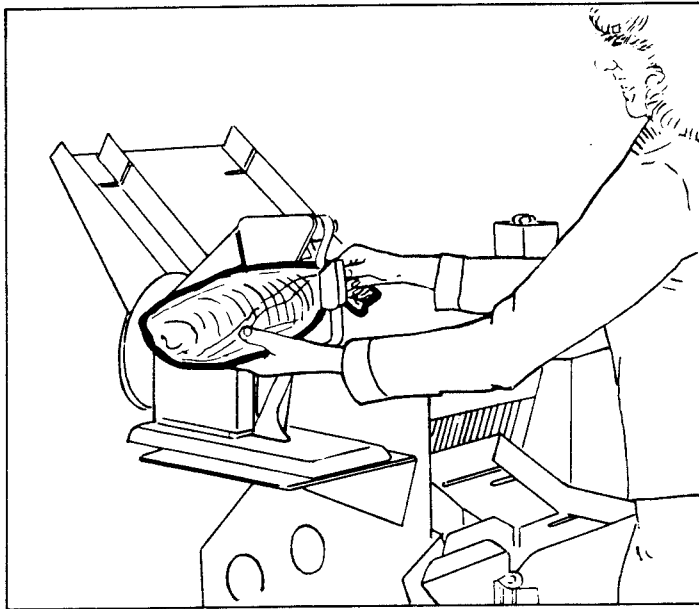

13. The bag may now be closed.

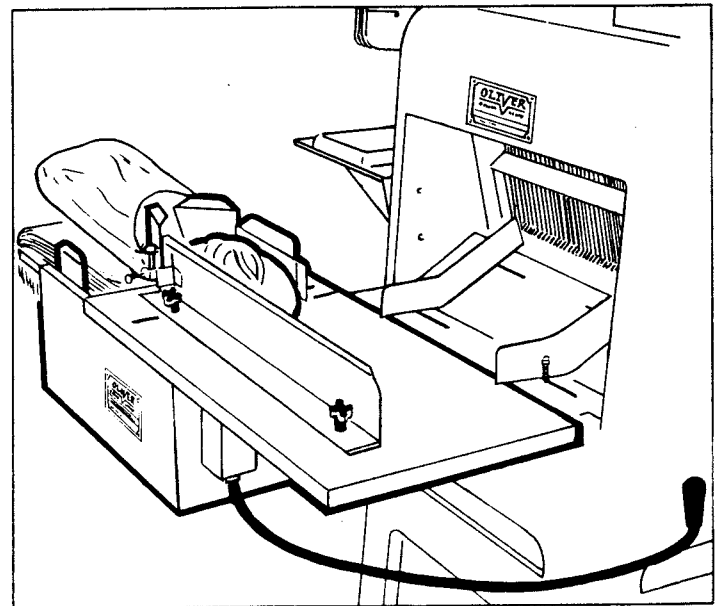

14. The next bag should fill with air, waiting for the next loading operation.

OPTIONAL OR SPECIAL FUNNELS:

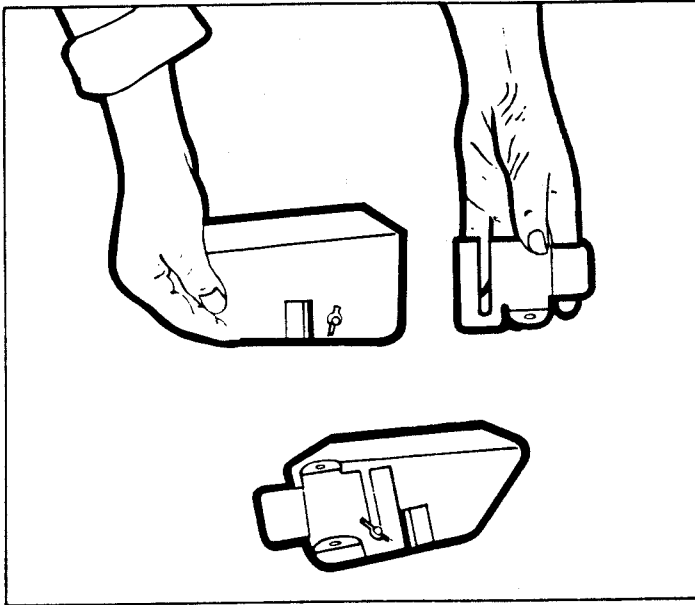

The adjustable funnels provided with your OLIVER bagger will work on a wide range of product shapes and sizes. Still, occasions may arise where a special funnel may be required.

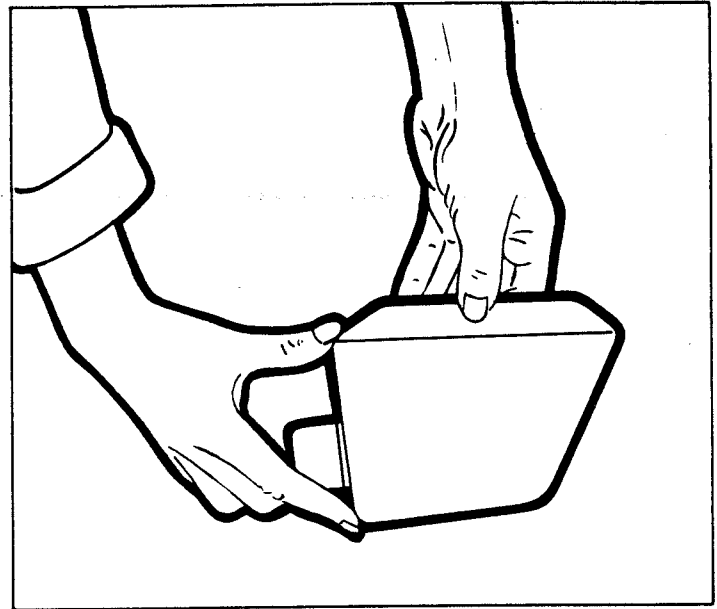

Shorter, taller or specially shaped funnels may be purchased at additional cost, from OLIVER PRODUCTS COMPANY. When asking for a special height funnel specify the dimension shown above when ordering.

NOTE:

Funnel height as well as product height and width will effect the bag width. If the funnels can not open fully into the bag, your bag may be too small, or your funnels may be too high.

INSTALLING A COUNTER WEIGHT
ON A MODEL 797-32, 797-48, or 797-PB SLICER

All Model 797-32, 797-48, and 797-PB slicers when equipped with a Model 1179S bagger MUST HAVE a counter weight attached to the slicer as illustrated below. New slicers shipped with a bagger from the factory will have a weight already attached to the machine. Older slicers having a bagger added in the field will require the addition of this weight. The weight when shipped for field installation will be furnished with four 1/4-inch bolts, washers and lock washers for mounting to the top of the caster brackets as shown below. The weight should be placed on the right side of the machine, (standing on the outfeed side of the slicer). Should your machine be fitted with casters you must first remove the four outside bolts from the casters, on the right hand side, and then install the weight as above. At this time using the four hex nuts, washers and lock washers, included in the weight package, secure the casters as shown in the illustration below.

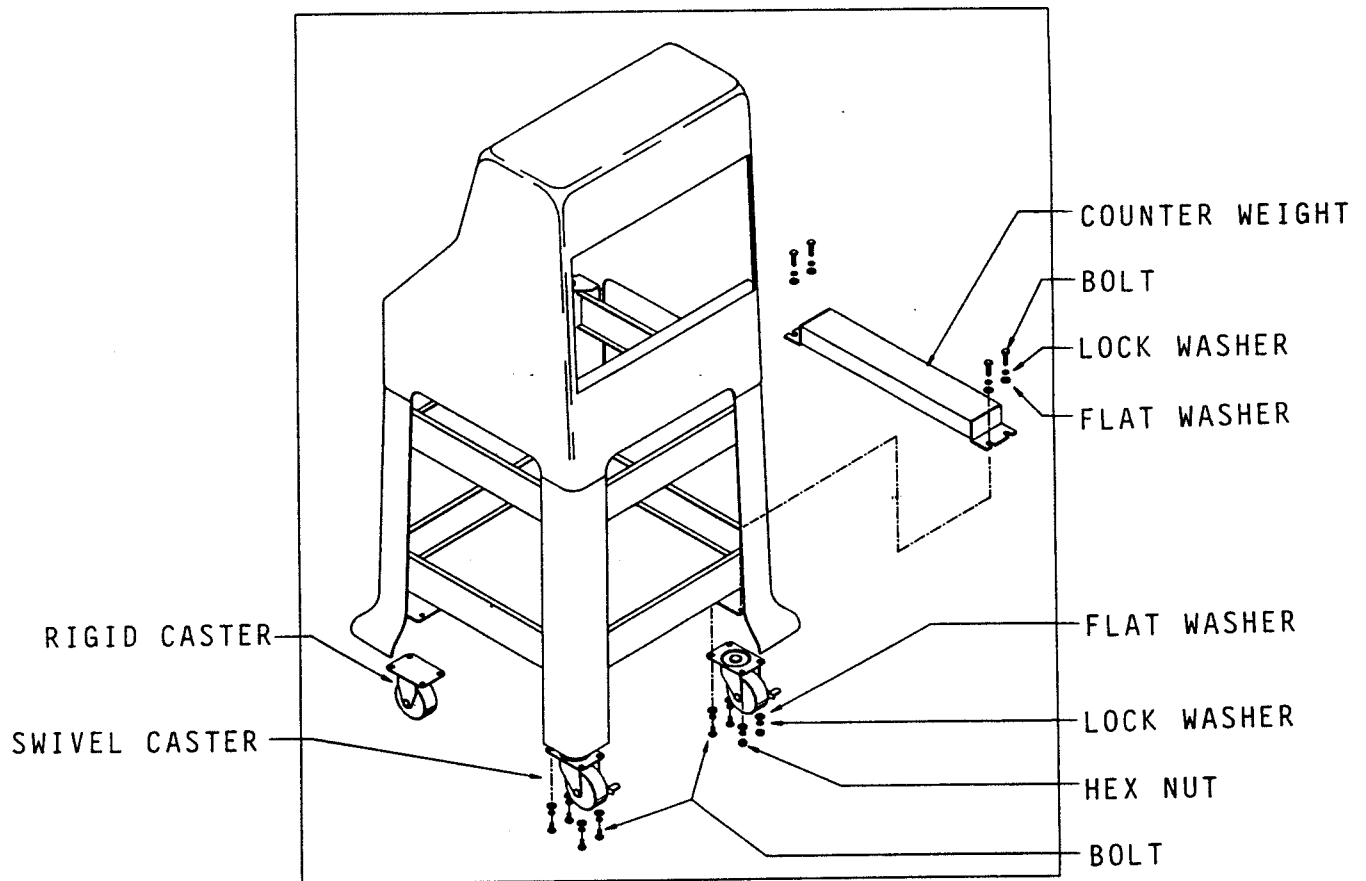

FIELD INSTALLATION OF AN 1179S BAGGER

The first thing which must be done with your new bagger is to attach it to the slicer. If your slicer is an older machine which you are adding the bagger to, follow steps 1 - 12. If you have purchased both new at the same time, part of the job is already done and you must only do steps 8 - 12. In either case the first thing you must do is make sure the slicer is on a flat level surface and also make sure that the power cord is disconnected from the power supply.

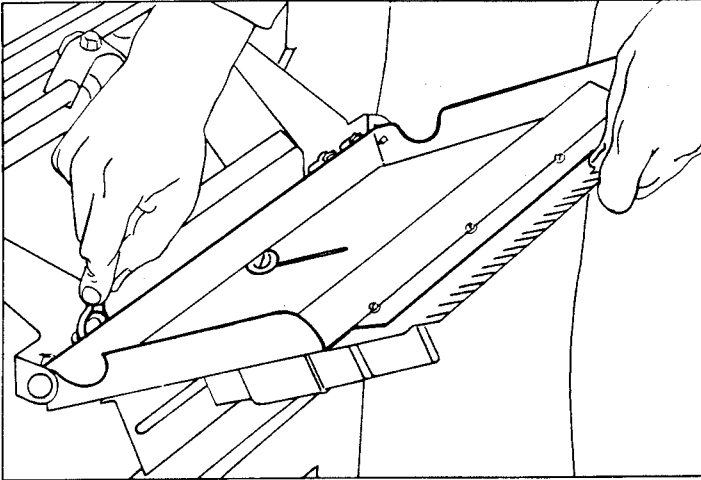

1. Remove the outfeed table from your slicer by removing the table mounting bracket as shown.

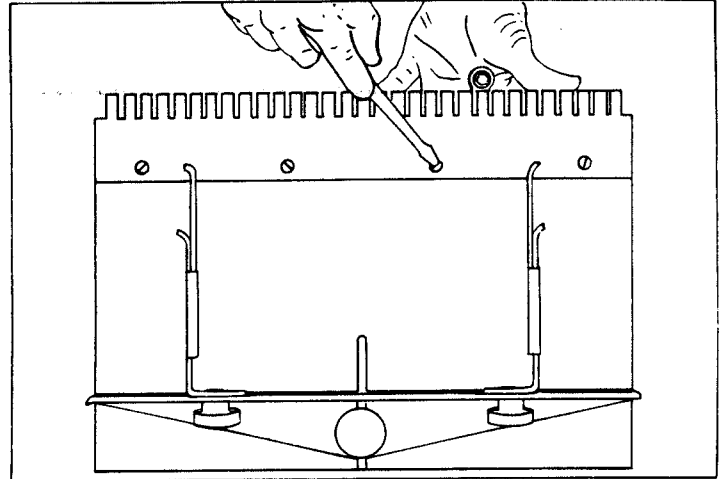

2. Remove the table lip from your old outfeed table.

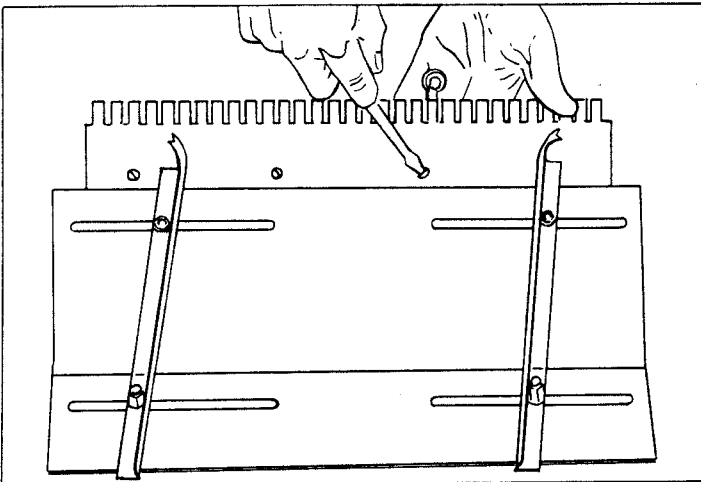

3. Attach the table lip to your new outfeed table which compliments your 1179 Bagger.

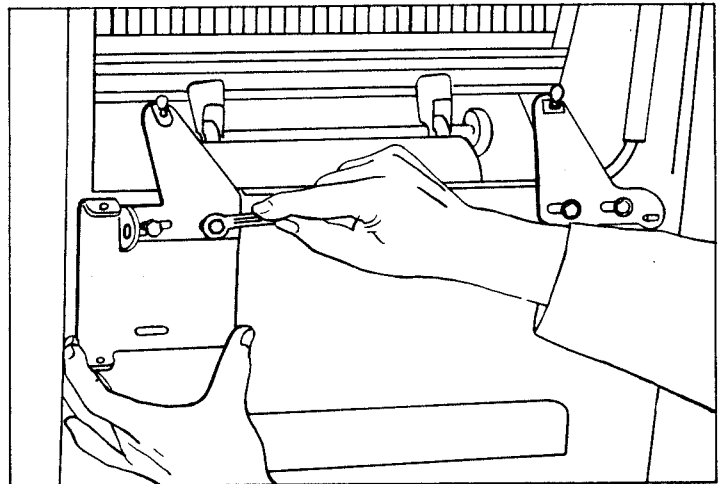

4. Find the new table and bagger mounting bracket shipped with your new bagger. Install it using only the top (2) 1/4" bolts & lockwashers. Do not tighten them at this time.

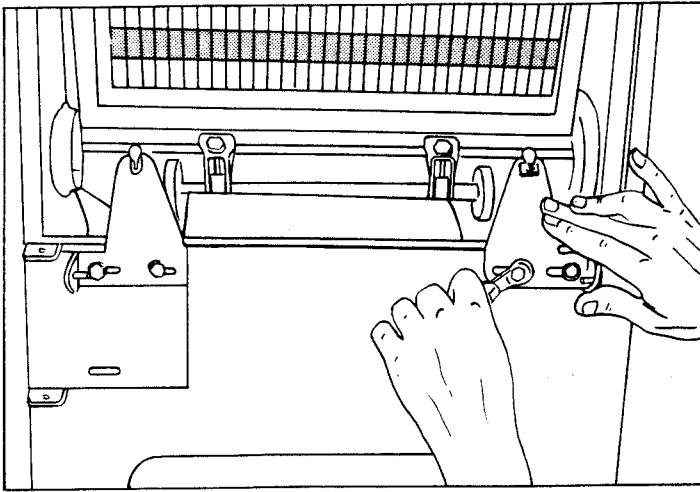

5. Loosen the remaining table bracket so it can be easily adjusted.

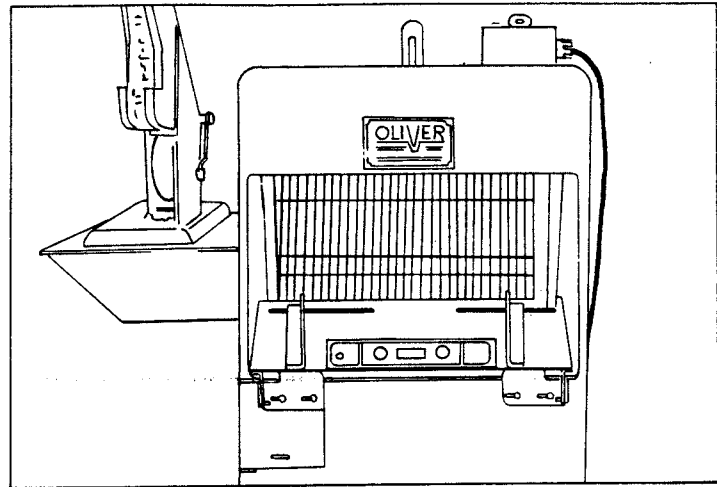

6. Install the new outfeed table and lip on the table brackets. Adjust it so that the slicer blades are centered in the table lip slots and that the end of the outfeed table is level. When satisfied tighten the table bracket bolts.

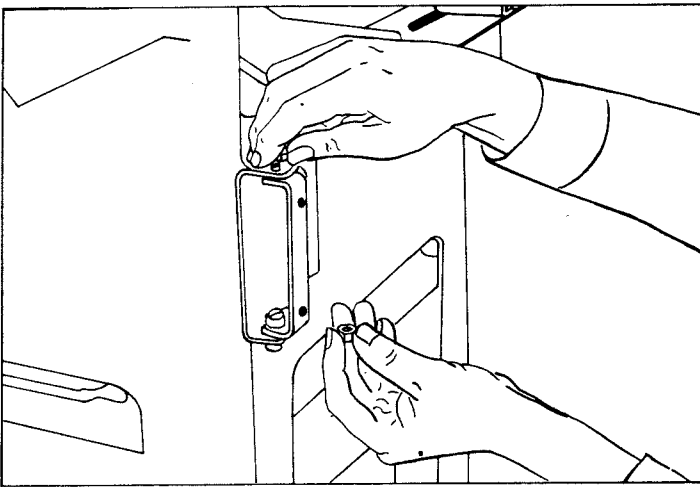

7. Install the case mounting bracket placing its' flanges between those of the bracket mounted on the slicer. Then insert the 5/16" bolts and secure with the 5/16" locknuts provided. The case bracket should be tight but still able to pivot.

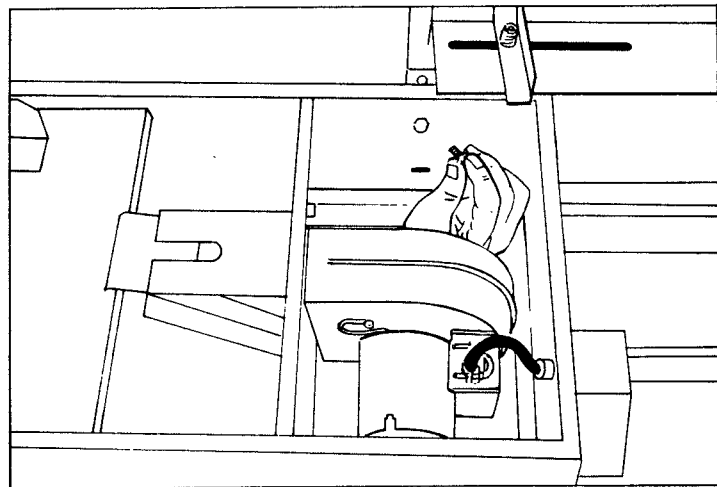

8. Mount the bagger to the case bracket by installing (2) 1/4" bolts, washers and lockwashers. Note the slot in the case which is used for later leveling.

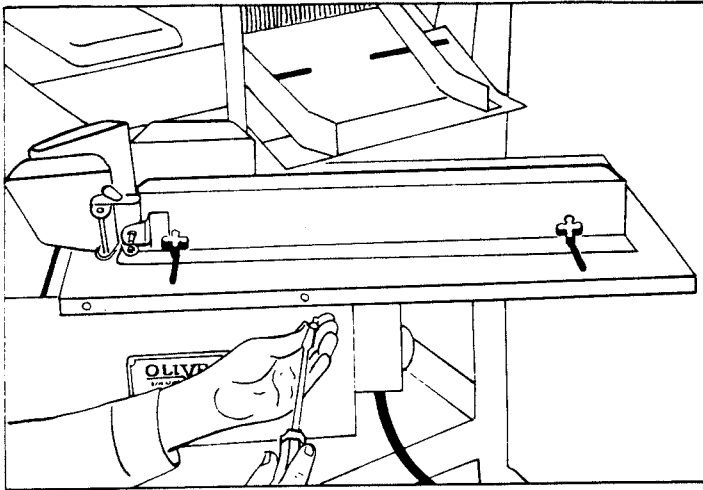

9. Install the bagger infeed table.

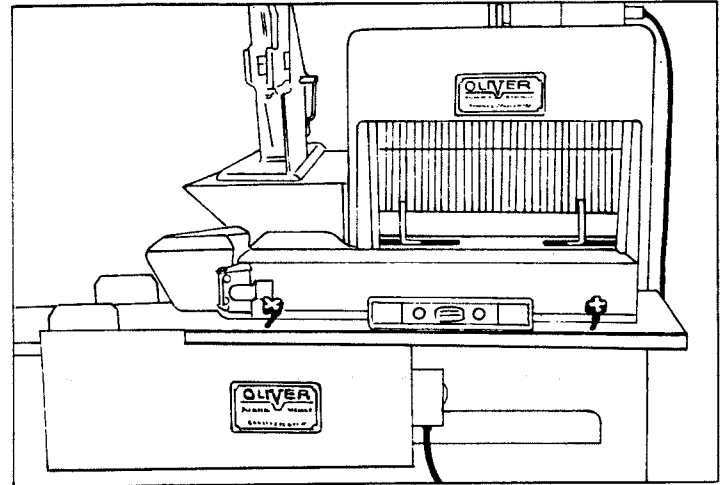

10. Square and level your bagger with the slicer outfeed table. The bagger should slide beneath the slicer outfeed table when correctly installed. When satisfied tighten all mounting bolts.

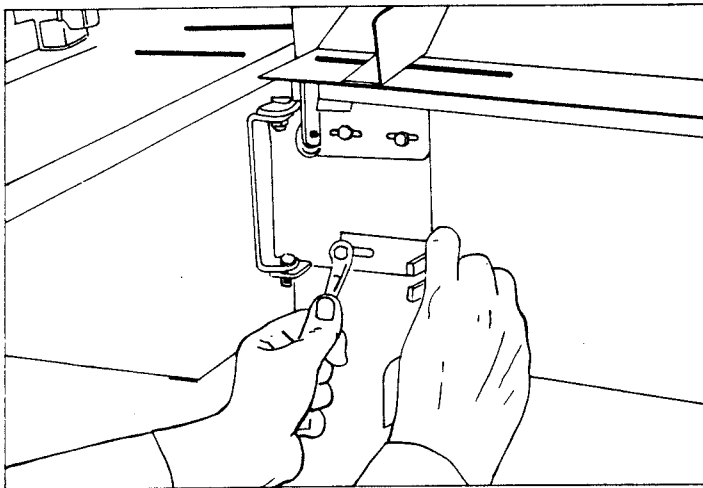

11. Install the case locking bracket in the 3rd hole in the table mounting bracket. Before tightening align it with the rear edge of the bagger, then tighten the one 1/4" mounting bolt securely.

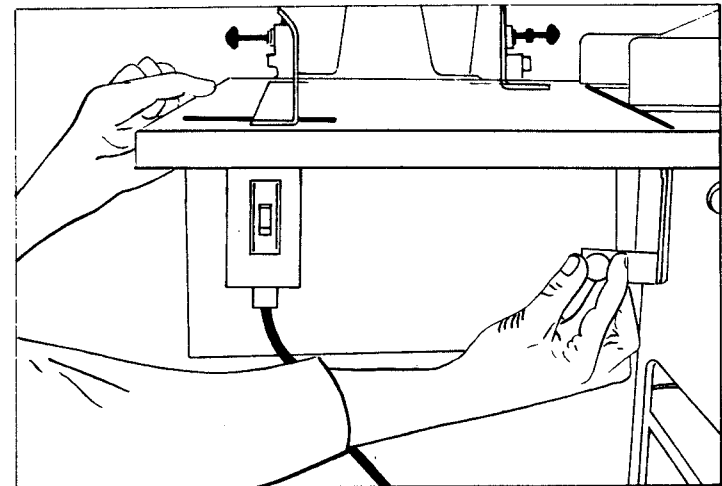

12. The threaded portion of the clamping knob should swing into the slot of the case locking bracket. Tighten the clamping knob securely. The bagger may then be connected to the special convenience outlet provided on the slicer. If the plug and outlet are not the same and cannot be connected your machines are not the same voltage; contact the factory.

Your bagger is now installed. Re-connect the slicer to the power supply and then test run the slicer, checking blade clearances, etc. Readjust if necessary; if not the installation is complete.

1179 FUNNEL REPLACEMENT

In cases where either a special height or one-piece funnel is needed it becomes necessary to remove and replace the funnels on your bagger. Start by removing the side guide assemblies from the machine. The funnels which are attached to the side guides, can then be replaced by following the steps shown below.

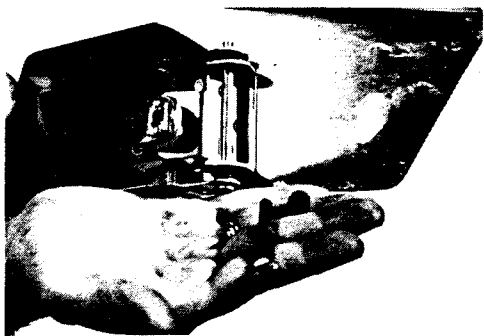

1. Remove the rubber stop and stop screw.

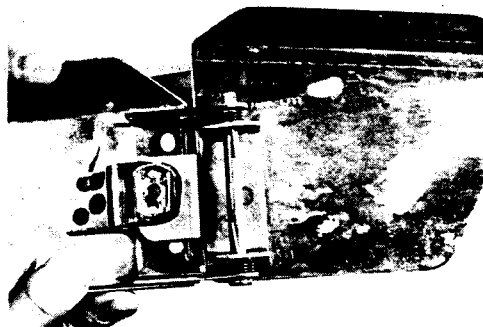

2. Note the position of the springs, bearings and pin. Be sure to replace them to this same location.

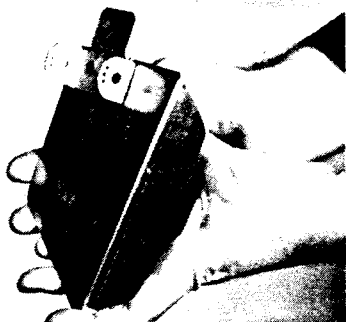

3. The three holes in the funnel allow for some spring adjustment, if required. Generally the center hole is used. Note which hole is used on your assemblies and try that hole first when re-assembling.

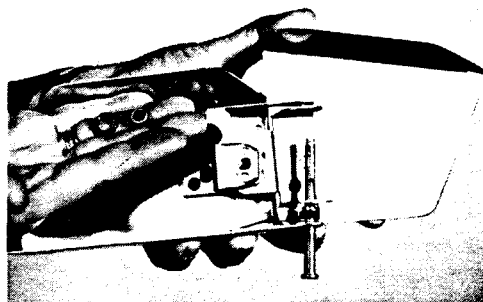

4. Remove the clevis pin after which the other components can also be removed. Remember to replace all springs, bearings, etc. to their original position.

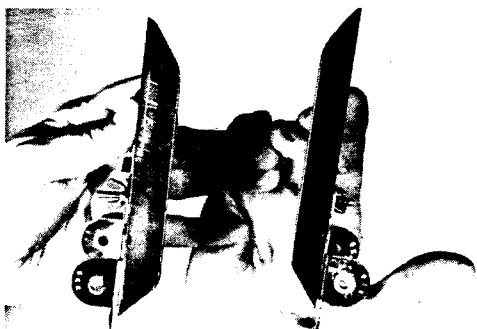

5. As the funnel parts are made opposite, make sure you have the correct part for the side you are working with.

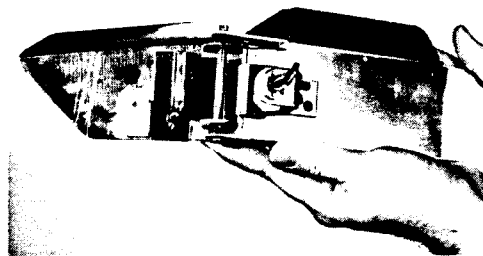

6. Re-assemble the spring, bearings, pin and stop screw to their original position. Check operation and increase or decrease spring tension if desired.

PARTS LISTS 1179S BAGGER

NOTE: Items not identified on this sheet or drawing are standard hardware items which may be purchased locally.

*Optional Items		
<u>Item No.</u>	<u>Item Description</u>	<u>Part Number</u>
1	Tray-Bag	1079-0014-001
2	Locator-Bag	1079-0016
3	Case RH	1179-0001-0001
4	Table Infeed RH	1179-0002-0001
5	Weight	1179-0003
6	Lip	1179-0004
7	Stud-DE	4625-3508-135
8	Knob	4560-2508-1105
9	Cord 115 V.	1179-0017
*9	Cord 230 V.	1179-0018
10	Cord-Motor	1179-0019
11	Blower 1-50/60/115	6310-5020
*11	Blower 1-50/60-230	6310-5021
12	Guide-Short RH	1179-0005-0001
13	Guide-Long RH	1179-0006-0001
14	Cap-Neoprene	5106-8920
15	Brg. Brz 1/4x3/8x1/4	5254-0058
16	Knob	5911-7100
17	Pin-Clevis 1/4x3	5915-8060
18	Spring	7030-0001
19	Spring	7030-0003
20	Bracket-Stop RH	1179-0013-0001
21	Bracket-Stop LH	1179-0013-0002
22	Table-Outfeed	1179-0008
23	Guide-Side RH	1179-0009-0001
24	Guide-Side LH	1179-0009-0002
25	Washer-Nylon	5851-8120
26	Spring	7012-2101
27	Brkt-Table Hinge RH	0797-3013-0001
28	Brkt-Pivot RH	1179-0010-0001
29	Brkt-Case Mtg.	1179-0011
30	Brkt-Case Lock	1179-0012
31	Screw-Set 1/4-20x1-1/4	5843-2039
32	Funnel-Adjustable RH 4-5-1/2"	1179-0014-0011
*32	Funnel- One Piece RH 4"	1179-0007-0001
*32	Funnel-One Piece RH 3"	1179-0007-0011
33	Funnel-Adjustable LH 4-5-1/2"	1179-0014-0012
*33	Funnel-One Piece LH 4"	1179-0007-0002
*33	Funnel-One Piece LH 3"	1179-0007-0012
34	Nameplate - Caution	6400-3006
35	Bolt-Carriage 1/4-20 x 1-1/2	5804-1706
36	Nut - Acorn 1/4-20	5832-0590
37	Foot-Rubber	5902-0011
*38	Extension- Bag Tray	1079-0020-001
*39	Nut Bar	4460-1008-1001
*40	Knob	5911-7014
*41	Support-Bag	1079-0021-001
42	Strain Relief	5765-1080
43	Enclosure-Switch	5764-8070
44	Switch	5758-0002

(Rev. 1-4-06)

1179S20006

OLIVER MODEL 1179S BAGGER

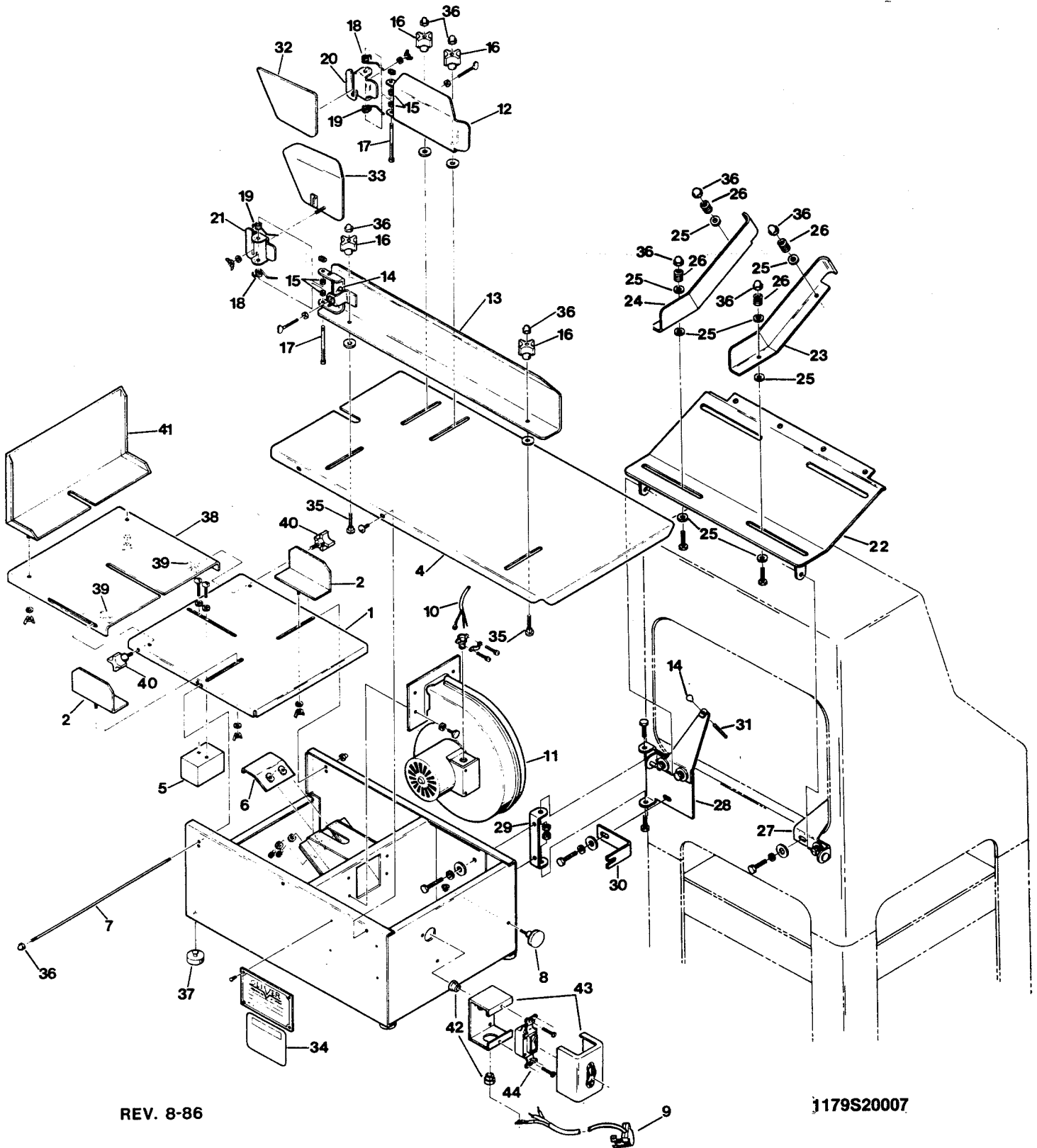

REV. 8-86

1179S20007

BAG SPECIFICATION FOR OLIVER BAGGERS

BASIC BAGS

Most applications using the OLIVER bagger will be for either polyethylene or polypropylene bags. These bags must be of an extended lip design and mounted on a wicket, ideally about 250 bags per wicket. The bag can be purchased in different constructions as shown below.

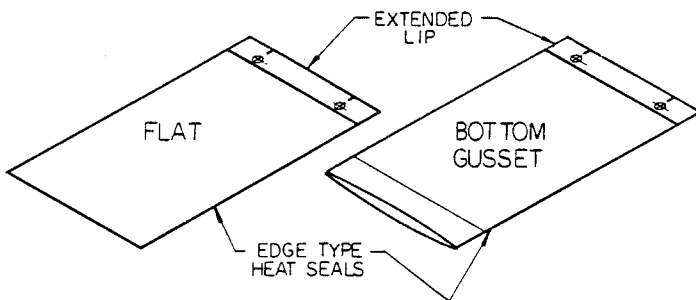

As other bags of either different construction or different materials can be purchased, we would suggest that if you desire to use one of these bags that your best course of action would be to obtain sample bags and to try them, as this would give you the best and most reliable answer to their acceptability.

SIZE SELECTION

The next thing you must determine is the bag size needed for your product. It is important to state here that the looser the fit between the product and the bag the easier it will be to insert the product, thereby increasing the speed of packaging. Conversely a tighter fit will generally result in a better looking package, but slower and more difficult packaging.

What follows is only "a rule of thumb" formula, and before placing an order with the bag manufacturer, sample bags should be tested for their acceptability. As all bagging machines are a little different it also follows that the bag may differ for the same product run on different baggers.

Bag Width

The minimum width of the bag can be roughly determined by adding the width + height, or, (the circumference divided by two, on irregular shapes), and adding 1/2" to 1". A 13" wide bag is the maximum width which can be used on an OLIVER bagger.

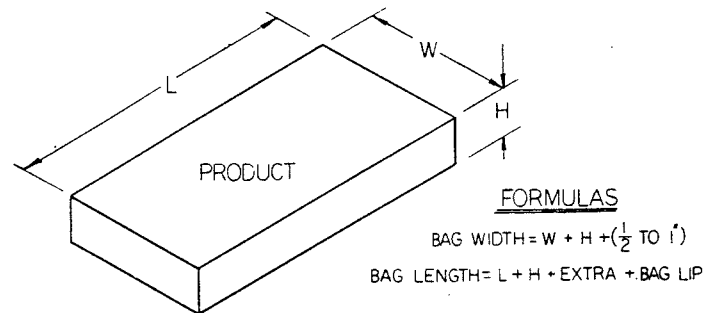

Bag Length

The length of the bag can roughly be determined by adding the length + height of the product to an extra amount which must be determined by the user of the bagger based on the method which will be employed to close the bag; tying, taping, trim sealing, etc. This may be one to three or more inches depending on the closing method chosen.

LIP & WICKET SIZES

As mentioned before you must use extended lip design, wicketed bags. In general, the lip should be about 1½" long with the center line of the wicket holes about 1" from the edge. Often there is a cut above the wicket holes to aid the bag in tearing from the wicket during loading.

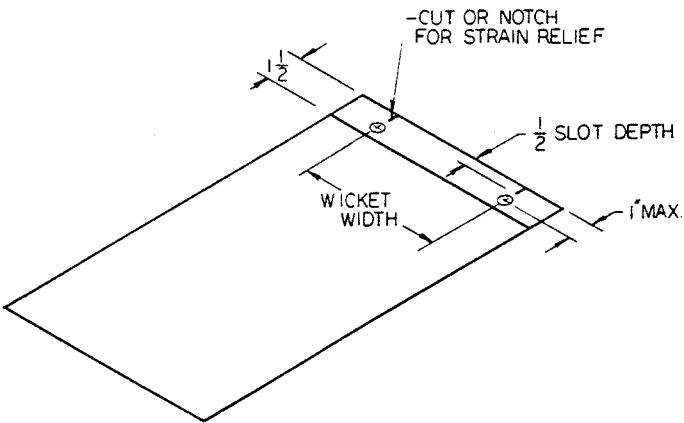

The width of the wicket should never be more than the maximum width of the product to be bagged, and should be centered on the bag. Note: If the wicket were wider than the product you would have to have a wider bag than normally required to handle the same size product.

BAG OPTIONS

We would like to mention a few of the bag options available, see the following illustration.

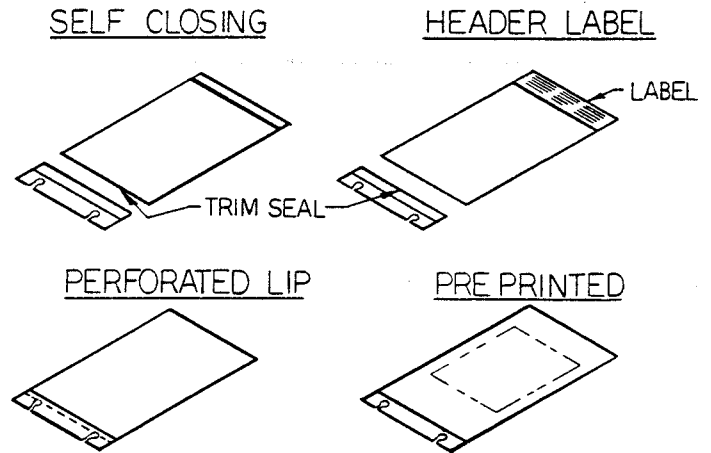

Consult your bag supplier for additional types and additional information on their availability for your application.

**THIS PAGE WAS INTENTIONALLY
LEFT BLANK.**



WARRANTY

PARTS

Oliver Packaging & Equipment Company (Oliver) warrants that if any part of the equipment (other than a part not manufactured by Oliver) proves to be defective (as defined below) within one year after shipment, and if Buyer returns the defective part to Oliver within one year, Freight Prepaid to Oliver's plant in Grand Rapids, MI, then Oliver, shall, at Oliver's option, either repair or replace the defective part, at Oliver's expense.

LABOR

Oliver further warrants that equipment properly installed in accordance with our special instructions, which proves to be defective in material or workmanship under normal use within one (1) year from installation or one (1) year and three (3) months from actual shipment date, whichever date comes first, will be repaired by Oliver or an Oliver Authorized Service Dealer, in accordance with Oliver's published Service Schedule.

For purposes of this warranty, a defective part or defective equipment is a part or equipment which is found by Oliver to have been defective in materials workmanship, if the defect materially impairs the value of the equipment to Buyer. Oliver has no obligation as to parts or components not manufactured by Oliver, but Oliver assigns to Buyer any warranties made to Oliver by the manufacturer thereof.

This warranty **does not** apply to:

1. Damage caused by shipping or accident.
2. Damage resulting from improper installation or alteration.
3. Equipment misused, abused, altered, not maintained on a regular basis, operated carelessly, or used in abnormal conditions.
4. Equipment used in conjunction with products of other manufacturers unless such use is approved by Oliver Products in writing.
5. Periodic maintenance of equipment, including but not limited to lubrication, replacement of wear items, and other adjustments required due to installation, set up, or normal wear.
6. Losses or damage resulting from malfunction.

The foregoing warranty is in lieu of all other warranties expressed or implied AND OLIVER MAKES NO WARRANTY OF MERCHANTABILITY OR FITNESS FOR PURPOSE REGARDING THE EQUIPMENT COVERED BY THIS WARRANTY. Oliver neither assumes nor authorizes any person to assume for it any other obligations or liability in connection with said equipment. OLIVER SHALL NOT BE LIABLE FOR LOSS OF TIME, INCONVENIENCE, COMMERCIAL LOSS, INCIDENTAL OR CONSEQUENTIAL DAMAGES.



Oliver Packaging & Equipment Company
511 Sixth Street NW • Grand Rapids, MI 49504

(800) 253-3893
www.oliverquality.com

WARRANTY PROCEDURE

1. If a problem should occur, either the dealer or the end user must contact the Parts and Service Department and explain the problem.
2. The Parts and Service Manager will determine if the warranty will apply to this particular problem.
3. If the Parts and Service Manager approves, a Work Authorization Number will be generated, and the appropriate service agency will perform the service.
4. The service dealer will then complete an invoice and send it to the Parts and Service Department at Oliver Products Company.
5. The Parts and Service Manager of Oliver Packaging and Equipment Company will review the invoice and returned parts, if applicable, and approve for payment.



Oliver Packaging & Equipment Company
511 Sixth Street NW • Grand Rapids, MI 49504

(800) 253-3893
www.oliverquality.com

RETURNED PARTS POLICY

This policy applies to all parts returned to the factory whether for warranted credit, replacement, repair or re-stocking.

Oliver Packaging and Equipment Company requires that the customer obtain a Return Material Authorization (RMA) number before returning any part. This number should appear on the shipping label and inside the shipping carton as well. All parts are to be returned prepaid. Following this procedure will insure prompt handling of all returned parts.

To obtain an RMA number contact the Repair Parts Department toll free at (800) 253-3893.

Parts returned for re-stocking are subject to a **RE-STOCKING CHARGE**.

Thank you for your cooperation,

Repair Parts Manager
Oliver Packaging and Equipment Company