



Grand Rapids, Michigan, U.S.A. 49504-5298

USER'S OPERATING AND INSTRUCTION MANUAL

MODEL 623

HAND BUN / ROLL
DOUGH DIVIDER

SAFETY INSTRUCTIONS

Various safety devices and methods of guarding have been provided on this machine. It is essential, however, that machine operators and maintenance personnel observe the following safety precautions. Improper installation or operation of this equipment may cause injury to personnel or equipment.

1. Read this manual before attempting to operate your machine. Never allow an untrained person to operate or service this machine.
2. Connect the machine to a properly grounded electrical supply that matches the requirements shown on the electrical specification plate and follow specifications of local electrical codes.
3. Disconnect and lock-out the machine from the power supply before cleaning or servicing.
4. Check and secure all guards before starting the machine.
5. Observe all caution and warning labels affixed to the machine.
6. Use only proper replacement parts.
7. Do not wear loose fitting clothing or loose hair. Shirt tails should be tucked in.
8. Wear proper personal safety equipment.
9. Keep Hands away from the moving parts of this machine while it is in operation.
10. In addition to these general safety instructions, also follow the more specific safety instruction given for the different areas of the machine in the operating instructions.

DO NOT USE FOR OTHER THAN ORIGINALLY INTENDED PURPOSE

36 PART BUN/ROLL DOUGH DIVIDER
MODEL D-1

TECHNICAL DETAILS, OVERALL DIMENSIONS AND WEIGHT

CAPACITY: 36 pieces up to 4 ounces each.

Each machine is supplied with a stainless steel pan.

Dividing knife is electroless nickel plated, which gives years of use without corrosion.

DIMENSIONS: 19" x 17" x 28" high.

SHIPPING WEIGHT: Approx. 150 lbs.

INSTALLATION AND SET UP

Place the Dough Divider in a convenient location on a strong table or stand and bolt it down, through the 3 holes in the base plate (no.6).

Sanitary standards for food processing areas require a clean, adequately lighted and ventilated room.

The stainless steel pan should be washed with soapy water, rinsed clean and dried.

HOW TO OPERATE DOUGH DIVIDER

1. Scale the dough.
2. Place piece of scaled dough in the pan (#15) and flatten by hand.
3. Place pan with the dough under main plate (#8) and pull down operating handle (#11) to flatten the dough in the pan.
4. Hold operating handle in lower position and push top lever (#10) evenly, with a smooth motion and continue to pull down operating lever until dough is cut.

(cont'd)

5. Lift operating lever to the top position and remove pan containing 36 equally divided pieces of dough.

HOW TO CLEAN THE DOUGH DIVIDER

It is recommended practice to clean the machine after use. To clean the machine follow these steps:

1. Remove pan and place quick pin in hole on right hand guide bar (#4)
2. Gently pull down operating handle (#11)
3. Push top lever (#10) to release knife (#1) and pull operating lever into lower position.
4. Pull out right hand pin (#5), and swivel Arch #7 to the left.
5. Clean inside main plate and knife. It is recommended practice to use vacuum cleaner with long narrow nozzle.

To put the machine in working position, just reverse the above steps.

**OLIVER PRODUCTS COMPANY
MODEL 623 HAND DIVIDER
MECHANICAL PARTS LIST**

<u>ITEM NO.</u>	<u>PART DESCRIPTION</u>	<u>PART NUMBER</u>
01	KNIFE (36 PART) KNIFE (16 PART)	0623-0001 0623-0001-001
	*KNIFE/GEAR ASS'Y (SEE OPTIONS)	
02	GEAR HANDLE	0623-0002-1
03	GEAR SHAFT W/CROSS (36 PART) GEAR SHAFT W/CROSS (16 PART)	0623-0003 0623-0003-001
04	GUIDE BAR	0623-0004
05	RIGHT HAND PIN	0623-0005
06	BASE PLATE	0623-0006
07	ARCH	0623-0007
08	MAIN PLATE (36 PART) MAIN PLATE (16 PART)	0623-0008 0623-0008-001
09	COVER PLATE (36 PART) COVER PLATE (16 PART)	0623-0009 0623-0009-001
10	TOP LEVER	0623-0010
11	OPERATING HANDLE	0623-0011
12	BALANCE WEIGHT	0623-0012
13	PINION PIN	0623-0013
14	PIN	0623-0014-1
15	STAINLESS STEEL PAN	0623-0015
16	SPRING-TORSION #186	7030-0022
17	QUICK PIN	5835-7621

OLIVER PRODUCTS COMPANY
 MODEL 623 HAND DIVIDER
 MECHANICAL PARTS LIST

<u>ITEM NO.</u>	<u>PART DESCRIPTION</u>	<u>PART NUMBER</u>
18	SCREW-FLAT HD 3/8-16x1-1/4 SS	5843-5116
19	SCREW-HEX HD 3/8-16x3/4 SS	5843-1052
20	SCREW-HEX HD 3/8-16x1/4 SS	5843-1055
21	NUT-HEX FULL 3/4-10 NC SS	5832-0527
22	WASHER-3/4 FLAT 18-8 SS	5851-9310
23	OILER-BALL STYLE GB GITS 00521	5133-6071
24	RING-RETAINER 0.710 ID SS	5840-1668

OPTIONS

<u>PART DESCRIPTION</u>	<u>PART NUMBER</u>
KNIFE/CROSS ASS'Y (36 PART)	0623-0017
KNIFE/CROSS ASS'Y (16 PART)	0623-0017-001
FLOOR STAND	0623-25004

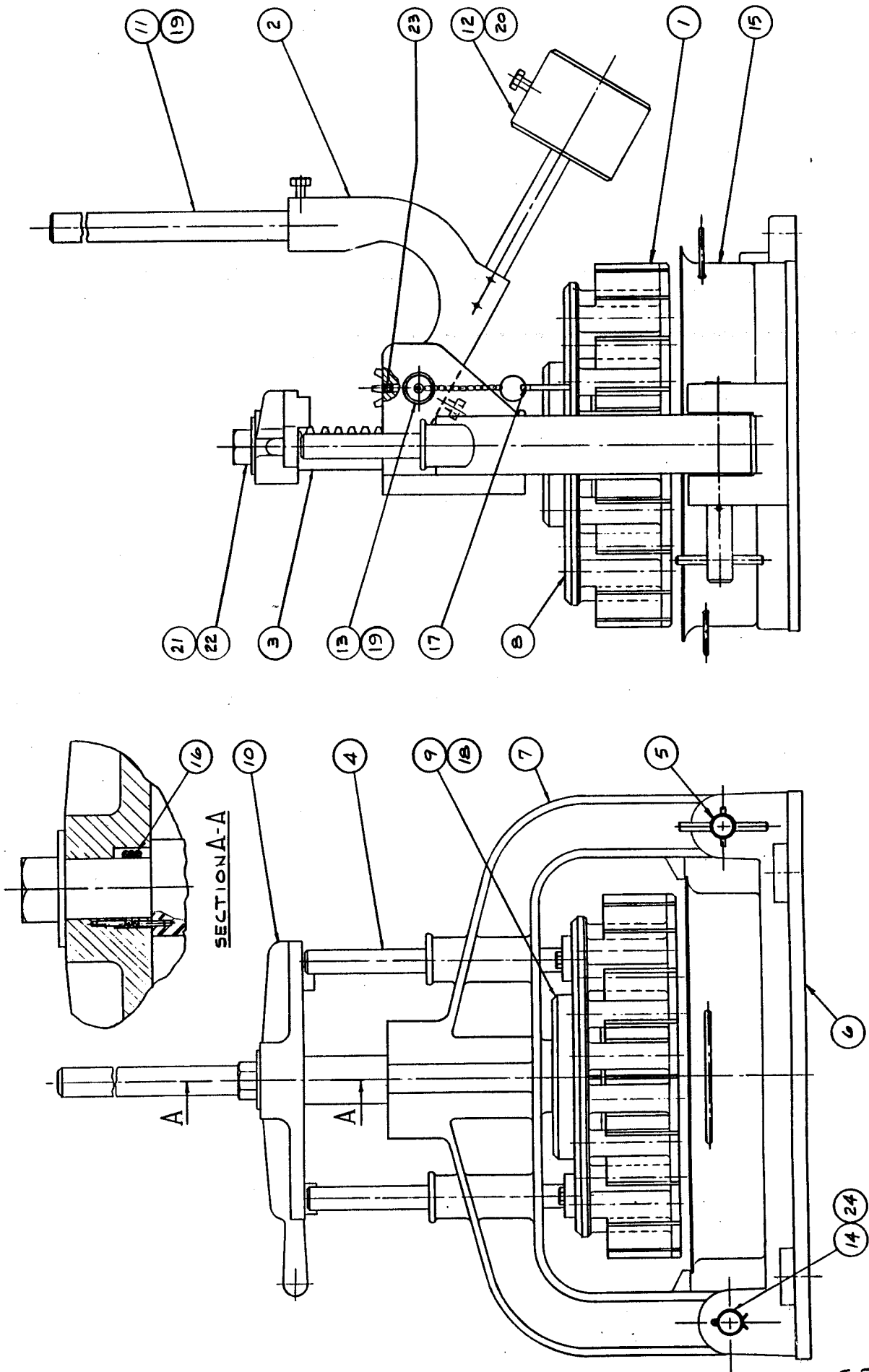

520005

**THIS PAGE WAS INTENTIONALLY
LEFT BLANK.**

WARRANTY

PARTS

Oliver Products Company (Oliver) warrants that if any part of the equipment (other than a part not manufactured by Oliver) proves to be defective (as defined below) within one year after shipment, and if Buyer returns the defective part to Oliver within one year, Freight Prepaid to Oliver's plant in Grand Rapids, MI, then Oliver, shall, at Oliver's option, either repair or replace the defective part, at Oliver's expense.

LABOR

Oliver further warrants that equipment properly installed in accordance with our special instructions, which proves to be defective in material or workmanship under normal use within one (1) year from installation or one (1) year and three (3) months from actual shipment date, whichever date comes first, will be repaired by Oliver or an Oliver Authorized Service Dealer, in accordance with Oliver's published Service Schedule.

For purposes of this warranty, a defective part or defective equipment is a part or equipment which is found by Oliver to have been defective in materials workmanship, if the defect materially impairs the value of the equipment to Buyer. Oliver has no obligation as to parts or components not manufactured by Oliver, but Oliver assigns to Buyer any warranties made to Oliver by the manufacturer thereof.

This warranty **does not** apply to:

1. Damage caused by shipping or accident.
2. Damage resulting from improper installation or alteration.
3. Equipment misused, abused, altered, not maintained on a regular basis, operated carelessly, or used in abnormal conditions.
4. Equipment used in conjunction with products of other manufacturers unless such use is approved by Oliver Products in writing.
5. Periodic maintenance of equipment, including but not limited to lubrication, replacement of wear items, and other adjustments required due to installation, set up, or normal wear.
6. Losses or damage resulting from malfunction.

The foregoing warranty is in lieu of all other warranties expressed or implied **AND OLIVER MAKES NO WARRANTY OF MERCHANTABILITY OR FITNESS FOR PURPOSE REGARDING THE EQUIPMENT COVERED BY THIS WARRANTY.** Oliver neither assumes nor authorizes any person to assume for it any other obligations or liability in connection with said equipment. **OLIVER SHALL NOT BE LIABLE FOR LOSS OF TIME, INCONVENIENCE, COMMERCIAL LOSS, INCIDENTAL OR CONSEQUENTIAL DAMAGES.**

**THIS PAGE WAS INTENTIONALLY
LEFT BLANK.**

WARRANTY PROCEDURE

1. If a problem should occur, either the dealer or the end user must contact the Customer Service Department and explain the problem.
2. The Customer Service Manager will determine if the warranty will apply to this particular problem.
3. If the Customer Service Manager approves, a Work Authorization Number will be generated, and the appropriate service agency will perform the service.
4. The service dealer will then complete an invoice and send it to the Customer Service Department at Oliver Products Company.
5. The Customer Service Manager of Oliver Products Company will review the invoice and returned parts, if applicable, and approve for payment.

**THIS PAGE WAS INTENTIONALLY
LEFT BLANK.**

RETURNED PARTS POLICY

This policy applies to all parts returned to the factory whether for warranted credit, replacement, repair or re-stocking.

Oliver Products Company requires that the customer obtain a Return Material Authorization (RMA) number before returning any part. This number should appear on the shipping label and inside the shipping carton as well. All parts are to be returned prepaid. Following this procedure will insure prompt handling of all returned parts.

To obtain an RMA number contact the Repair Parts Department toll free at (800) 253-3893.

Parts returned for re-stocking are subject to a **RE-STOCKING CHARGE**.

Thank you for your cooperation,

Repair Parts Manager
Oliver Products Company