



Grand Rapids, Michigan, U.S.A. 49504-5298

**USER'S OPERATING AND INSTRUCTION MANUAL**

**MODEL 688-N**

QUARTER-RACK ELECTRIC CONVECTION OVEN



MODEL 688-N

INDEX

<u>Section Description</u>	<u>Document No.</u>	<u>Page No.</u>
SAFETY INSTRUCTIONS -----	0688S20002 -----	1-1
DESCRIPTION/SPECIFICATIONS -----	0688S20003 -----	2-1
Description -----		2-1
Physical Specifications -----		2-1
INSTALLATION / SETUP -----	0688S20004 -----	3-1
Inspection -----		3-1
Location Selection -----		3-1
Sealing Oven to Mounting Surface -----		3-1
Oven Setup -----		3-2
Electrical Connection -----		3-2
Venting -----		3-3
Test Cycle -----		3-4
OPERATING INSTRUCTIONS -----	0688S20005 -----	4-1
Beginning Operation -----		4-1
Adjusting the Temperature -----		4-1
Turning Oven Off -----		4-1
Adjusting the Moveable Shelves -----		4-1
TROUBLESHOOTING -----	0688S20006 -----	5-1
Temperature Calibration (Re-calibration) -----		5-3
MAINTENANCE -----	0688S20007 -----	6-1
Cleaning -----		6-1
Lubrication -----		6-1
Removal and Replacement Guide -----		6-2
RECOMMENDED SPARE PARTS -----	0688S20008 -----	7-1
REPLACEMENT PARTS SECTION		
HOUSING / CHAMBER ASSEMBLY -----	0688S20009 -----	8-1
Drawing -----		8-1
Parts List -----		8-2
LINER ASSEMBLY -----	0688S20010 -----	9-1
Drawing -----		9-1
Parts List -----		9-2

Continued



MODEL 688-N

**INDEX (Continued)**

<u>Section Description</u>	<u>Document No.</u>	<u>Page No.</u>
DOOR ASSEMBLY -----	0688S20011 -----	10-1
Drawing -----		10-1
Parts List -----		10-2
FRONT CONTROL PANEL ASSEMBLY-----	0688S20012 -----	11-1
Drawing -----		11-1
Parts List -----		11-2
ELECTRICAL SUB PANEL -----	0688S20013 -----	12-1
Drawing -----		12-1
Parts List -----		12-2
REAR COVER ASSEMBLY -----	0688S20014 -----	13-1
Drawing -----		13-1
Parts List -----		13-2
COVER ASSEMBLY -----	0688S20015 -----	14-1
Drawing -----		14-1
Parts List -----		14-2
ELECTRICAL DIAGRAM -----	0688S20017 -----	15-1
Three Phase Wiring Diagram 208 / 240 375 / 480 V -----		15-1
WARRANTY -----	GEN 050816	
WARRANTY PROCEDURE -----	GEN 050817	
RETURNED PARTS POLICY-----	GEN 050818	



MODEL 688-N

## SAFETY INSTRUCTIONS

### **WARNING**

**VARIOUS SAFETY DEVICES AND METHODS OF GUARDING HAVE BEEN PROVIDED ON THIS OVEN. IT IS ESSENTIAL HOWEVER THAT THE OVEN OPERATORS AND MAINTENANCE PERSONNEL OBSERVE THE FOLLOWING SAFETY PRECAUTIONS. IMPROPER INSTALLATION, MAINTENANCE, OR OPERATION COULD CAUSE SERIOUS INJURY OR DEATH.**

1. Read this manual before attempting to operate your oven. Never allow an untrained person to operate or service this machine.
2. This oven must only be installed by qualified personnel. It also must be installed to the specifications of local plumbing and electrical codes. See the installation section of this manual for additional requirements.
3. Connect the oven to a properly grounded electrical supply that matches the requirements shown on the electrical specification plate and follow specifications of local electrical codes.
4. Disconnect and lock-out the oven from the power supply before cleaning or servicing.
5. Check and secure all guards before starting the oven.
6. Observe all caution and warning labels affixed to the oven.
7. Use only proper replacement parts.
8. Wear proper personal protective safety equipment.
9. Keep Hands away from the moving parts of this oven while it is in operation.
10. In addition to these general safety instructions, also follow the more specific safety instructions given for the different areas of the oven in the operating instructions.

### **WARNING**

**DO NOT USE FOR OTHER THAN ORIGINALLY INTENDED PURPOSE.**



MODEL 688-N

## DESCRIPTION/SPECIFICATIONS

### Description

The Oven is a stainless steel, electric, forced air, (convection), oven. This oven offers consistent baking at all rack levels due to the careful positioning of the heating and air circulation systems.

In addition to the above, this oven also offers many other features. It is well insulated with a high quality asbestos free insulation. It is compact, attractive, quiet, and is easily maintained. Should electrical servicing ever be required the electrical components are readily accessible by removing the side or back panels.

The tempered glass door allows a full view of the trays in the oven during baking.

The oven has one of the fastest temperature recoveries on the market allowing the oven to be turned off during non-peak hours, thus saving energy.

The oven has many protective features such as not allowing heating of the elements when the door is open. Other features are re-settable thermal overloads on the motor, and a high-limit thermostat.

The temperature control allows precise control of the baking temperature.

The moveable shelves allow greater flexibility.

### Physical Specifications

Electrical Options Available:

- 3 phase, 60 Hz, 208VAC, 24 Amps.
- 3 phase, 60 Hz, 240VAC, 27 Amps.
- 3 phase, 50 Hz, 375VAC, 11 Amps.
- 3 phase, 60 Hz, 480VAC, 14 Amps.

Product Capacities:

The Standard oven will hold (2 to 5) 18" X 26" pastry baking trays depending on the placement of moveable shelves.

When using 2 trays – maximum distance between trays is 9-3/4"

When using 3 trays – maximum distance between trays is 4-3/4"

When using 4 trays – maximum distance between trays is 3"

When using 5 trays – maximum distance between trays is 2-1/4"



MODEL 688-N

Space Requirements:

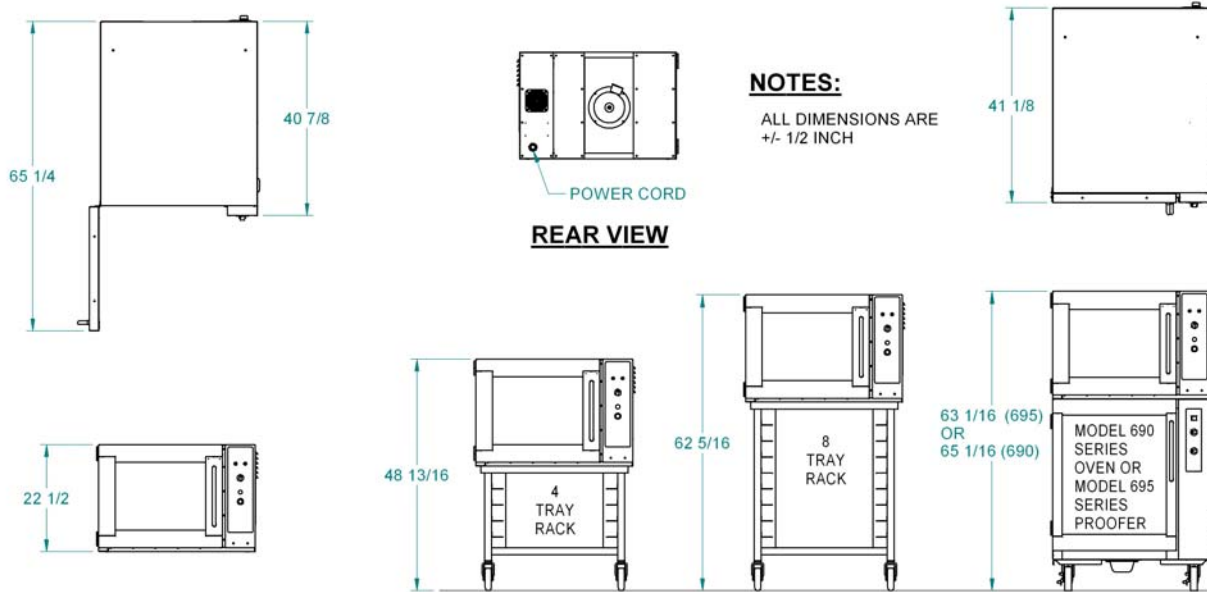

- Single: 41-1/8" Deep x 33" Wide x 22-1/2" high.
- Single with short stand and casters: 48-13/16" high.
- Single with tall stand and casters: 62-5/16" high
- Stacked 688 oven & 695 Proofer with casters: 63-1/16" high
- Stacked 688 & 690 ovens with casters: 65-1/16" high

Clearance:

Left side = 2".

Right side = 12" in a fixed location, (to have access to electrical components), or 2" when mounted on another unit which has casters.

Back side = 4" to allow for proper motor ventilation and electrical connection.

Net Weight: Approximately 300 pounds.

Shipping Weight: Approximately 350 pounds.



MODEL 688-N

## INSTALLATION / SETUP

### Inspection

Before accepting delivery inspect the carton and machine for damage. Note any damage found on the shipping documents. Remember shipping damage **is not** covered by your warranty, and is the responsibility of the carrier. Also report the damage to the dealer from which the oven was purchased for further direction and assistance in filing a claim with the carrier.

### Location Selection

Select a location where the oven will be used. The oven must be set on a flat level surface. It should have a grounded power supply of the same rating as shown on the nameplate located on the rear of the oven and this power supply must be capable of carrying the load that the oven will put on it (See "Electrical Connection" below).

Ovens mounted on other units with casters should be placed so that they have a minimum of two inches on each side and a minimum of four inches in the rear of the oven to provide for proper motor ventilation and electrical connection.

Ovens without casters should be placed so that there is a minimum of two inches on all sides, except for the side with the electrical panel, (right side), which should have a minimum of twelve inches. The rear of an oven without casters should be a minimum of four inches away from adjacent surfaces to allow room for the electrical connection and motor ventilation.

### Sealing Oven to Mounting Surface

## **CAUTION**

**MAKE SURE THAT THE MOUNTING SURFACE IS ABLE TO SUPPORT THE WEIGHT OF THE OVEN WHICH IS APPROXIMATELY 300 POUNDS PLUS AN ADEQUATE SAFETY FACTOR BEFORE PLACING IT ON THE SURFACE.**

The oven **must be** sealed to the mounting surface to comply with local sanitation codes. For the purpose of sealing the unit a tube of NSF/FDA approved silicone sealant has been provided with your unit. Apply, to the surface that the oven will rest on, a continuous bead of sealant approximately 1/2 inch in from each of the four sides of the oven. After the oven has been placed over this bead apply a second generous continuous bead at the joint where the oven contacts the mounting surface thus totally sealing the bottom of the oven to that surface.



MODEL 688-N

Oven Setup

Ovens may be mounted to a fixed surface, attached to an “Oliver” oven rack with casters or stacked on either a Oliver Model 690 Oven or and Oliver Model 695 Proofer. For associated mounting heights for the above options see page 2-2.

**CAUTION**

**USE CARE WHENEVER MOVING OVENS MOUNTED ON RACKS AS THEY ARE TOP HEAVY AND PRESENT A TIPPING HAZARD.**

Ovens attached to “Oliver” oven racks must be securely fixed to the rack with bolts. Stacked units should be setup as shown on page 2-2 being sure that the alignment pins on the top of the lower unit are securely positioned into the holes in the base of the upper oven.

Electrical Connection

**WARNING**

**THE OVEN MUST BE CONNECTED TO A PROPERLY GROUNDED ELECTRICAL SOURCE OF THE SAME RATING AS THE MACHINE. FAILURE COULD RESULT IN AN ELECTRICAL SHOCK WHICH MAY CAUSE INJURY OR DEATH.**

**WARNING**

**ALL WIRING AND ELECTRICAL REPAIRS SHOULD BE DONE BY A QUALIFIED ELECTRICIAN. FAILURE TO DO SO MAY CAUSE SERIOUS INJURY OR DEATH.**

**CAUTION**

**SPECIAL HEAVY DUTY ELECTRICAL SERVICES AND WALL DISCONNECTS MUST BE PROVIDED FOR SAFE OPERATION OF THE OVEN.**

The following service requirements are recommended, dependent on the voltage of the unit you have purchased. Your oven’s requirements can be found on the nameplate attached to its rear surface.





MODEL 688-N

Electrical Connection (continued)

For voltages other than those shown below please contact the factory. Check the voltage at the electrical disconnect before proceeding to the next step.

480 Volts = 20 Amp service  
375 Volts = 20 Amp service  
240 Volts = 30 Amp service  
208 Volts = 30 Amp service

The oven is shipped from the factory with a power cord, which does not include a plug. The power cord should be wired to a disconnect enclosure which is accessible from the oven work area, leave at least two feet of slack so that access can be gained to the ovens back and right side. A plug may be used between the disconnect enclosure and the oven instead of hard wiring as described above. This makes sliding the oven out for service more convenient. Whatever method is used the oven should be wired in a manner which would conform to the U.S. "National Electric Code".

**CAUTION**

**FANS MUST ROTATE IN THE CLOCKWISE DIRECTION FOR PROPER AIRFLOW. IMPROPER DIRECTION MAY CAUSE UNEVEN BAKES AND LONGER BAKING TIMES.**

Check fan rotation for clockwise direction. After the oven has been "Set Up" and connected to the electrical service do the following to check the rotation of the fans. Use the following sequence to start the oven to check fan rotation direction:

- Turn the main power switch on, (green button). The oven blower motor should start. Once started the fan rotation can be checked.
- Once complete, turn the main power switch off, (red button).

If the rotation is incorrect remove and interchange any two of the three incoming power leads (red, white and black), at the plug or disconnect enclosure and retest.

Venting

The gap between the door and the housing of the model 688 oven is designed to be the vent for the oven. SOME STEAM MAY ESCAPE THROUGH THE FRONT DOOR GASKET.



MODEL 688-N

## **WARNING**

**HOT STEAM ESCAPING WHILE OPENING DOOR CAN CAUSE SEVERE BURNS.  
STAND BACK WHILE OPENING DOOR TO AVOID INJURY.**

### Test Cycle

After completing the Set Up, and Electrical connections, you may wish to run the oven through a test cycle to verify that everything is ready. Use the following sequence to test the oven.

- Turn the main power switch on, (green button). The fan should start.
- Adjust temperature to 350 degrees F using thermostat. The heat light should illuminate, then extinguish when oven reaches temperature.
- Once the oven reaches the set temperature the heating elements should cycle on and off as indicated by the heat light.
- The gap between the door and the housing of the model 688 oven is designed to be the vent for the oven. **SOME STEAM MAY ESCAPE THROUGH THE FRONT DOOR GASKET.**
- Once complete, turn the main power switch off, (red button).



MODEL 688-N

## OPERATING INSTRUCTIONS

### Beginning Operation

First turn the oven on by pressing the green “On” button. The green “Power” lamp should be illuminated, oven blower will start, and heater will be turned on if temperature setting is higher than the temperature inside of oven.

Green “Power” lamp is illuminated anytime units is on.

Red “Heat” lamp is illuminated anytime heater is on. (When oven is up to temperature the lamp is off) lamp will continue to cycle on/off with heaters.

Oven blower and heater will turn off anytime door is opened regardless of temperature. Normal blower and heater operation will resume after door is closed.

### Adjusting Temperature

Adjust the temperature of the oven by turning dial to correspond to the temperature desired. Allow oven to reach temperature before baking. If adjusting to a lower temperature, it may be necessary to allow oven to cool by leaving door open for a few minutes.

### Turning Oven Off

Turn oven off by pressing the red “Off” button.

### Adjusting Moveable Shelves

6 moveable shelves are provided – 3 (RH) right hands, 3 (LH) left hands.

For 2 shelf operation – remove all moveable shelves.  
For 3 shelf operation – install 1 RH and 1 LH moveable shelves in center location.  
For 4 shelf operation – install 2 RH and 2 LH moveable shelves in locations closest, but not in, center.  
For 5 shelf operation – install 3 RH and 3 LH moveable shelves in center and the two outermost locations.

Shelves should be equally spaced for the best possible bake.

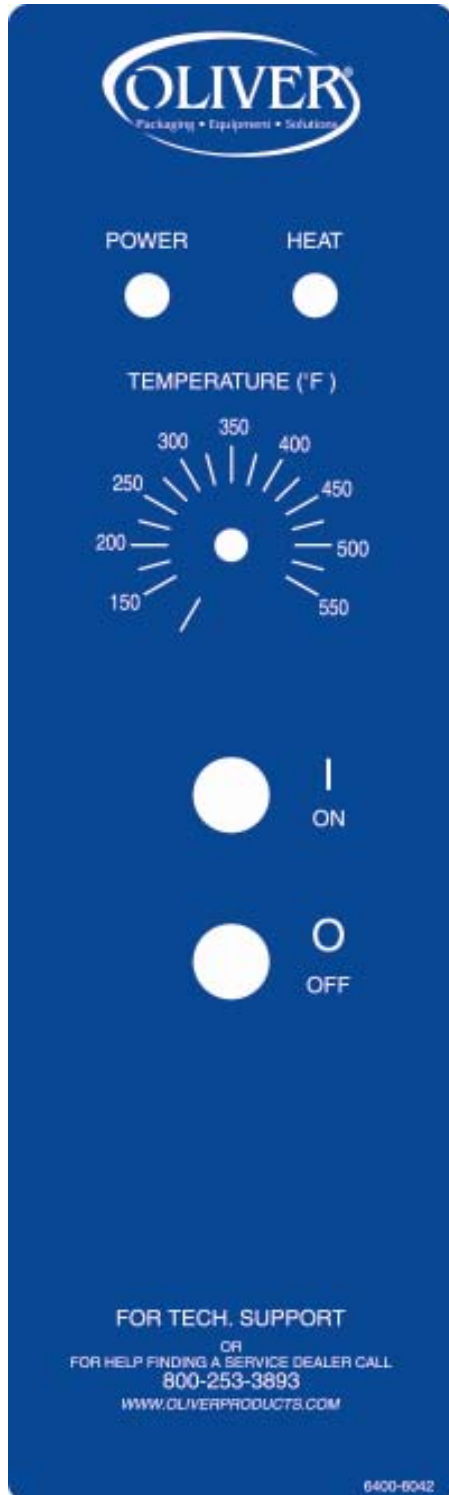



MODEL 688-N

## TROUBLESHOOTING

### **WARNING**

**TROUBLE SHOOTING OF ELECTRICAL EQUIPMENT SHOULD BE PERFORMED BY QUALIFIED PERSONNEL ONLY. ELECTRICAL POTENTIAL IS GREAT ENOUGH TO CAUSE INJURY OR DEATH.**

### **CAUTION**

**BEFORE WORKING ON A OVEN WHICH HAS BEEN RECENTLY USED  
ALLOW SUFFICIENT TIME FOR IT TO COOL TO PREVENT BURNS.**

*No Power – Oven Will Not Start.*

- The machine is not plugged in.
- There is no power available at the outlet/disconnect
- A fuse has blown.
- The transformer has failed. (Control panel only)
- Oven temperature is too high. (Your oven comes with a high temperature limit switch set at approx. 600 °F. This switch will reset when the oven has cooled.)
- Motor has overheated. (The blower motor is equipped with an internal thermal switch). Turn the oven off and try to restart after the motor has cooled.  
Possible causes:
  - 1.) The motor bearing or winding has failed.
  - 2.) Something is binding the motor or blower fan.
  - 3.) The rear of the oven lacks sufficient clearance to allow proper air circulation.

*No Heat or Oven Heats Slowly*

A cooled dry empty oven can be heated from room temperature to 300 °F in four to six minutes. If the oven is not meeting this specification, check the following.

- Check the fuses
- Check the two contactors.
- Check heater bank continuity.

(continued)



MODEL 688-N

**TROUBLESHOOTING (continued)**

*No Heat or Oven Heats Slowly (continued)*

- Oven temperature is too high. (Your oven comes with a high temperature limit switch set at approx. 600 °F. This switch will reset when the oven has cooled.)
- Motor has overheated. See page 5-1 for possible causes for this.
- A power interruption has occurred.

*The Door Will Not Close*

- Slamming the door can cause it to bounce off of the magnetic catches, not allowing the door time enough to latch properly.
- Check for a worn or broken hinges.

*The Blower Fan Will Not Run*

- The oven liner may be rubbing on the fan preventing its rotation.
- A motor fuse may need to be replaced.
- The door switch may not be working.
- Oven temperature is too high. (Your oven comes with a high temperature limit switch set at approx. 600 °F. This switch will reset when the oven has cooled.)
- Motor has overheated. See page 5-1 for possible causes for this.

*The Oven Is Overheating*

- A heat contactor may have failed.
- The oven may be out of calibration. See the Temperature Calibration section on page 5-3 to find out how to re-calibrate the oven.

(continued)



MODEL 688-N

## **TROUBLESHOOTING (continued)**

### *The Blower Fan Runs Continuously*

The blower fan should not run when the door is open. Things which may make this happen are:

- A failure of the door switch.
- A blower fan motor contactor failure.

### *The Oven is Baking Unevenly*

- The blower fan is turning in the wrong direction. (see installation instructions)
- Moveable shelves not spaced evenly.
- The oven may be out of calibration. See the Temperature Calibration section on page 5-3 (this page) to find out how to re-calibrate the oven.
- The blower fan may not be turning. See page 5-1 for possible causes for this
- You may have low voltage at the power source.

## **Temperature Calibration (Re-calibration)**

### *Temperature Adjustment*

Oven is calibrated from the factory. However should you find a difference between the "Set" temperature and the "Actual" oven temperature a correction can be made by doing the following. - 1). Place an accurate thermometer in the middle of the oven. 2). Set the oven thermostat to 350 deg. F. 3). Allow time for the temperature in the oven to stabilize. 4). If there is a difference between thermostat temperature and thermostat reading, adjust by loosening small screw in thermostat knob, turn knob carefully to correct setting (without turning shaft of thermostat) and re-tighten screw in knob. Re-check by allowing oven to cool for several minutes. Then re-test using steps 2 through 4 until thermostat setting corresponds to thermometer reading.



MODEL 688-N

## MAINTENANCE

### **WARNING**

**NEVER ATTEMPT TO CLEAN OR SERVICE THIS OVEN UNTIL IT HAS BEEN DISCONNECTED FROM THE POWER SUPPLY AND IS COOL TO THE TOUCH.**

### **NOTE**

**REMEMBER A CLEAN OVEN WILL LAST LONGER AND WORK BETTER.**

#### Cleaning

The outside of the oven should be cleaned daily by wiping it with a clean damp cloth or by using any suitable stainless steel cleaner. A solution made up of a mild detergent with water will normally be sufficient for routine cleaning of the interior of the oven. When finished dry the surfaces with a clean cloth.

The glass door should be cleaned daily using normal glass cleaners.

For more difficult cleaning jobs such as where there are burned on or greasy deposits, or heat tint, you should use an abrasive pad. Remember for best results always keep the stainless steel shiny.

To simplify major cleanings the door may be lifted off of the hinges and the inner liner may be removed by removing the six slotted head screws which secure the liner. Four of these screws are in the front of the oven while two additional screws are on the rear panel above and below the fan opening.

Clean the rear fan cover frequently to insure air circulation through the electrical compartment. This will lessen the possibility of heat related electrical problems.

The heating elements themselves normally do not require cleaning.

#### Lubrication

Occasionally put a few drops of oil on the pivot points of the door. No other items require lubrication.

### **CAUTION**

**NEVER LUBRICATE THE MOTORS**



MODEL 688-N

Removal and Replacement Guide

*Removing the Inner Liner:*

- Remove the six slotted head screws which secure the liner. Four of these screws are in the front of the oven while two additional screws are on the rear panel above and below the fan opening.
- The liner can now be removed from the oven.

*Replacing the Fan or Fan Motor:*

**WARNING**

**NEVER ATTEMPT TO CLEAN OR SERVICE THIS OVEN UNTIL IT HAS BEEN DISCONNECTED FROM THE POWER SUPPLY AND IS COOL TO THE TOUCH.**

- First remove the inner liner as described above.
- Next, use a wrench to remove the hex head bolt in the end of the motor shaft which secures the fan.
- Loosen the two set screws in the hub of the fan.
- Always use a puller to remove the fan from the motor shaft to protect the bearings in the motor.
- Disconnect wires from motor, wiring connections are in the wiring box on the motor.
- Take off the four nuts which secure the motor and remove the motor.
- Re-install the fans and/or motors by reversing the disassembly procedures.
- Be sure motor is in center of packing – adjust packing housing if necessary before installing blower wheel.

*Changing a Bank of Heating Elements.*

- Remove the inner liner as described above.
- Remove the fan as described above.





## MODEL 688-N

### *Changing a Bank of Heating Elements (continued)*

- Remove the electrical rear side panel by removing the 6 slotted head screws which secure the cover.
- Remove the wires from the ends of the bank of heating elements. Make sure they are marked so that they can be returned to the new bank of elements easily.
- Remove the four hex head screws which secure the bank to the housing and remove the bank of elements.
- The interior surface, where the bank of elements were previously attached, should be cleaned completely of any remaining sealant.
- A new bank of elements must be sealed to the housing using a NSF/FDA approved silicone sealant.
- Finish installing the new elements by reversing the above disassembly procedures.

### *Replacing the Door Gasket*

- Remove the 14 screws (including hinge screws) securing the inside and outside door panels together.
- Separate inside and outside door panels.
- Lay the inside door panel down and remove the glass and gasket from the metal frame.
- Replace gasket using a NSF/FDA approved sealant between the metal and gasket and gasket end to end.
- Set down door frame, rounded gasket side up and run a bead of NSF/FDA approved sealant around top edge of entire gasket.
- Place glass on top of gasket. This will seal the gasket to the glass.
- Allow sealant to dry, (approximately four to five hours).
- Replace door panel, clamp the front and back door panels together before tightening the screws.



MODEL 688-N

*Changing an Electrical Component*

**WARNING**

**NEVER ATTEMPT TO SERVICE THIS OVEN UNTIL IT HAS BEEN DISCONNECTED FROM THE POWER SUPPLY. ALL ELECTRICAL WORK MUST BE DONE BY A QUALIFIED ELECTRICIAN.**

- Remove the front side panel which is located on the control side.
- After identifying the component which needs to be replaced remove its wires after marking them for ease of replacement.
- Remove the component.
- Re-install the new component by reversing the above removal procedures.



MODEL 688-N

**RECOMMENDED SPARE PARTS**

<b><u>PART NUMBER</u></b>	<b><u>PART DESCRIPTION</u></b>	<b><u>NO. REQ'D</u></b>
5725-9614	Fuse-FRN-R-2 (208/240V)	1
5725-9439	Fuse-FNQ-R-2 (375/480V)	1
5725-9620	Fuse-FRN 4 (208/240V)	5
5725-9439	Fuse-FNQ-R-2 (375/480V)	3
5725-9440	Fuse-FNQ-R-2.5 (375/480V)	2
5725-9634	Fuse-FRN 30 (208/240V)	3
5725-9066	Fuse-KTKR-15 (375/480V)	3
5760-3194	Transformer (240/480V)	1
5760-3195	Transformer (208/375V)	1
5749-8021	Relay-Power 3-Pole, 25A	3
5749-5675	Relay-Control 2-Pole	2
5708-7806	Pushbutton-Green (On)	1
5708-7805	Pushbutton-Red (Off)	1
5757-8819	Switch-Magnetic Proximity Door	1
6542-0004	Glass-Door	1
6904-6062	Gasket-Door Interior and Exterior	12 ft
0690-0004	Motor-Blower (208/240/480V)	1
0690-0004-2	Motor-Blower (375V only)	1
0690-0045	Wheel-Blower	1
5712-0654	Sensor-RTD 1000 Ohm	1
5712-0029	Coupling-RTD Sensor	1
5730-2655	Heater-10KW (6.67KW Single Phase)	1
5757-9736	Switch-Thermal Surface Mount (Hi Limit)	1
6310-5027	Fan-Axial 3000 RPM (Cooling Fan)	1

For Service Parts Call Oliver Products @ 800-253-3893

**THIS PAGE WAS INTENTIONALLY  
LEFT BLANK.**



MODEL 688-N

HOUSING/CHAMBER ASSEMBLY

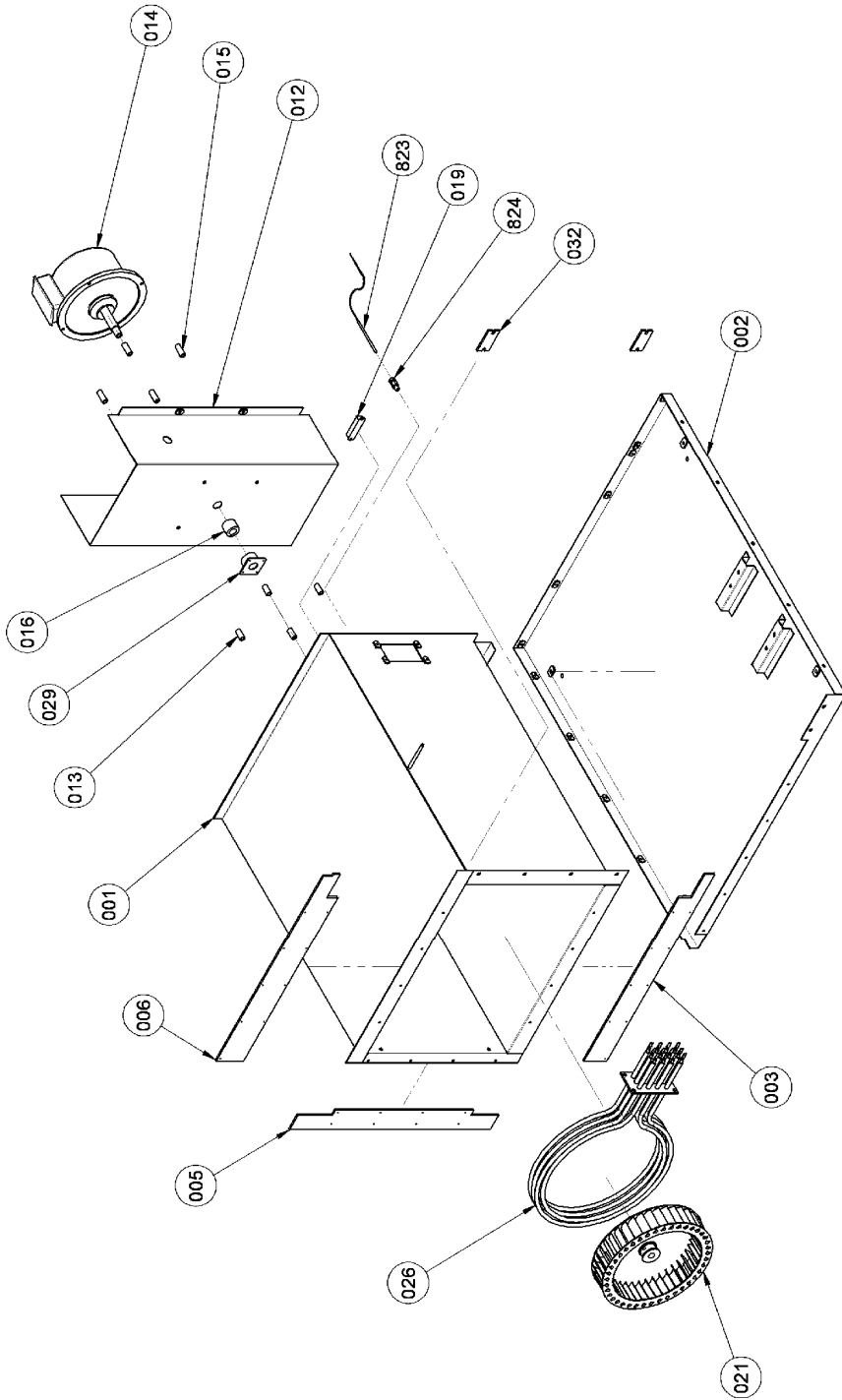

For Service Parts Call Oliver Products @ 800-253-3893



MODEL 688-N

**HOUSING/CHAMBER PARTS LIST**

<b>ITEM NO</b>	<b>PART DESCRIPTION</b>	<b>PART NUMBER</b>
001	Housing-Main	0688-0001
002	Base	0688-0002
003	Plate-Lower Splice	0688-0003
005	Plate-Side Splice	0688-0004
006	Plate-Upper Splice	0688-0005
012	Plate-Motor Mounting	0691-0006
013	Spacer-Short Motor	0690-0059
014	Motor-Blower 208/230/460/3ph	0690-0004
014	Motor-Blower 375/3ph	0690-0004-2
015	Spacer-Long Motor	0690-0058
016	Packing-PTFE Motor Shaft	5108-8602
019	Switch-Hi Limit	5757-9736
021	Wheel Blower	0690-0045
026	Heater-10KW	5730-2655
029	Housing-Adjustable Packing	0690-0158
032	Plate-Magnet	0688-0006
823	Probe-RTD 1000 Ohm	5712-0654
824	Fitting-Compression	5712-0029

For Service Parts Call Oliver Products @ 800-253-3893



MODEL 688-N

**LINER ASSEMBLY**

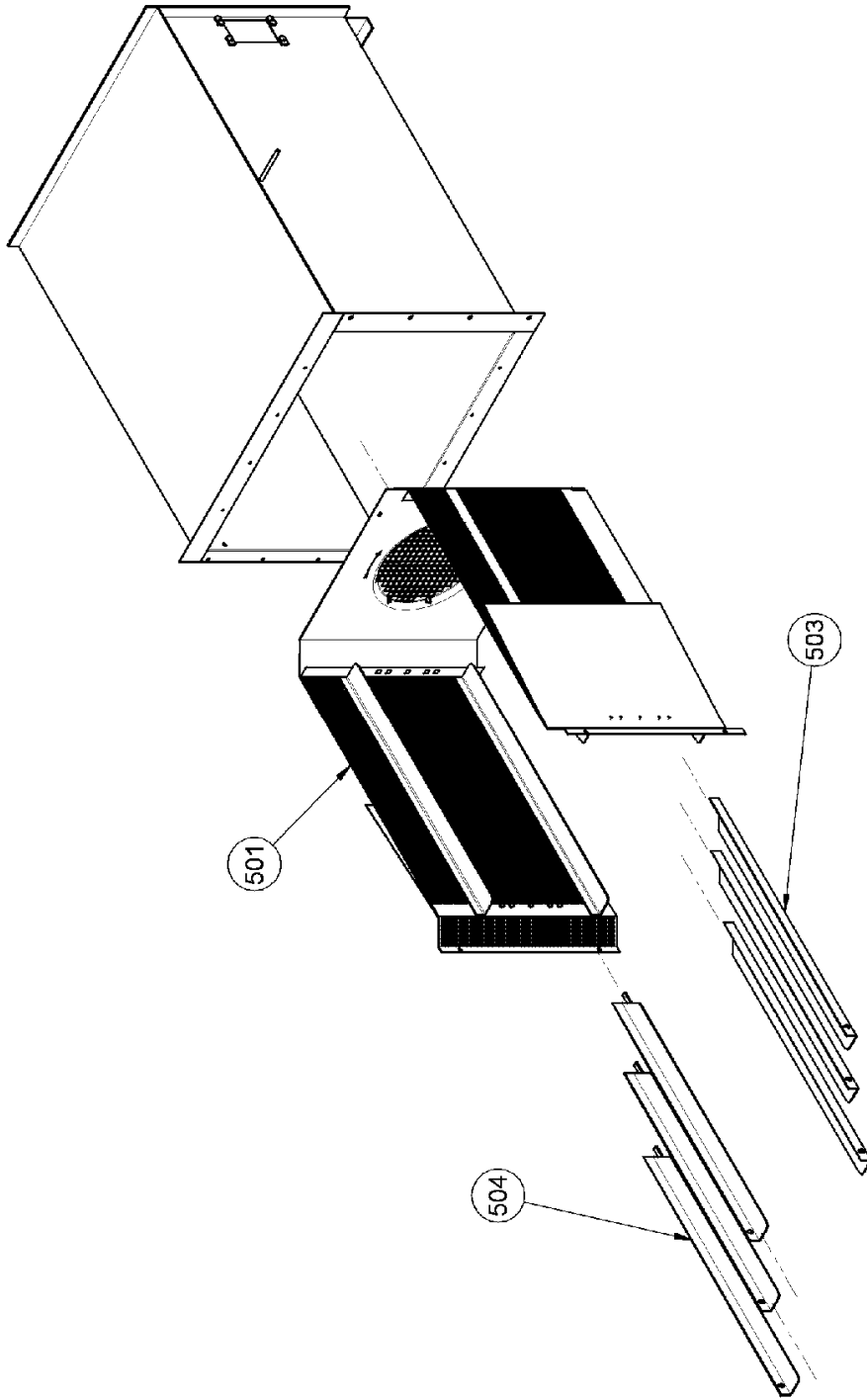

For Service Parts Call Oliver Products @ 800-253-3893



Oliver Packaging & Equipment Company  
511 Sixth Street NW • Grand Rapids, MI 49504

(800) 253-3893  
www.oliverquality.com

MODEL 688-N

**LINER PARTS LIST**

<b>ITEM NO</b>	<b>PART DESCRIPTION</b>	<b>PART NUMBER</b>
501	Liner – 2, 3, 4, or 5 Shelf	0691-0020-001
503	Auxiliary Shelf (RH)	0690-0072-0001
504	Auxiliary Shelf (LH)	0690-0072-0002

For Service Parts Call Oliver Products @ 800-253-3893





MODEL 688-N

**DOOR ASSEMBLY**

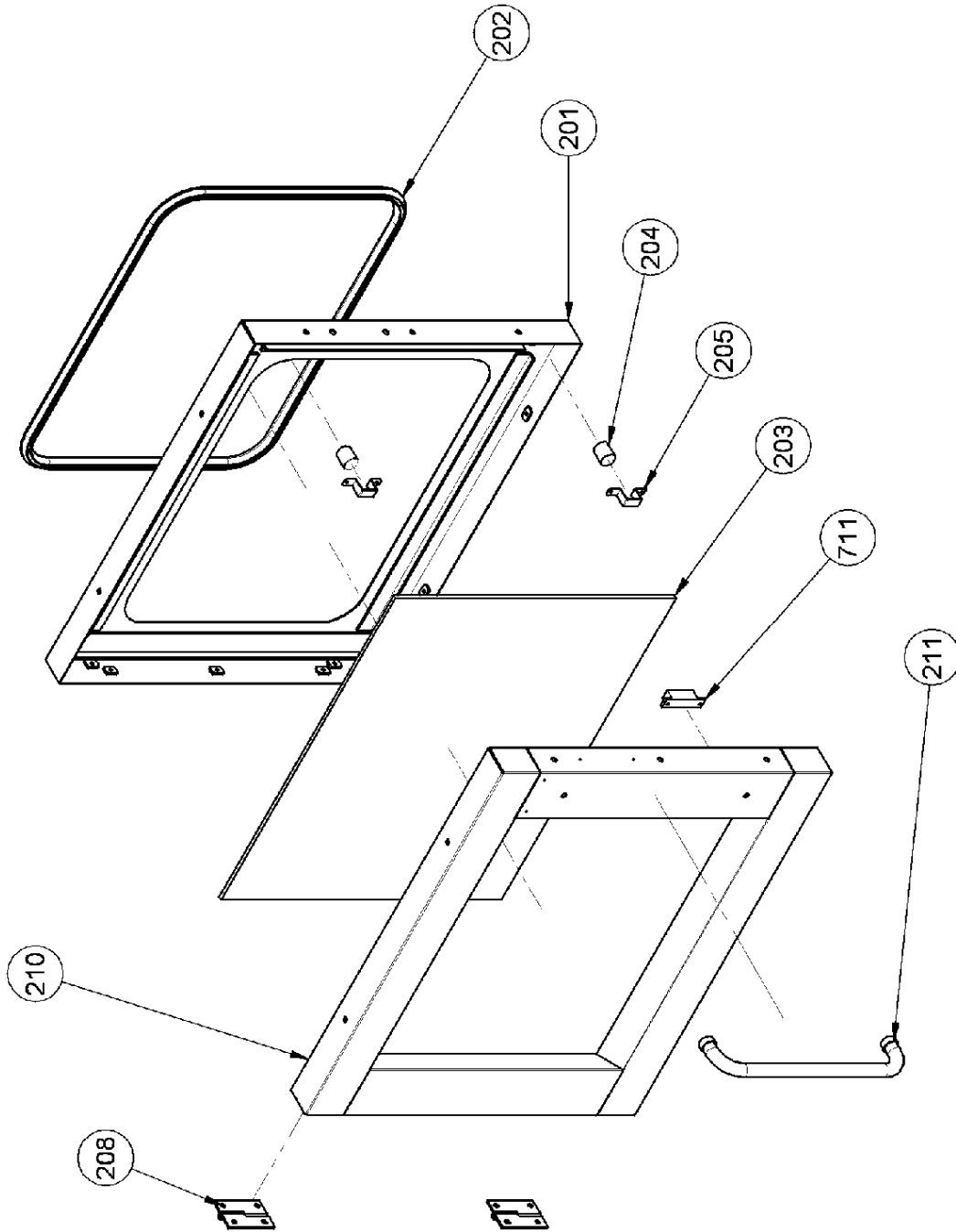

For Service Parts Call Oliver Products @ 800-253-3893



MODEL 688-N

**DOOR PARTS LIST**

<b>ITEM NO</b>	<b>PART DESCRIPTION</b>	<b>PART NUMBER</b>
201	Rear (Inside) Door Frame	0688-0007
202	Oven Door Gasket	6904-6062
203	Oven Door Glass	6542-0004
204	Magnet	5827-3000
205	Clamp – Magnet	0695-0017
208	Hinge	0695-0024
210	Front (Outside) Door Frame	0688-0008
211	Handle	5908-5116
711	Magnetic Proximity Switch	5757-8819

For Service Parts Call Oliver Products @ 800-253-3893



MODEL 688-N

FRONT CONTROL PANEL ASSEMBLY

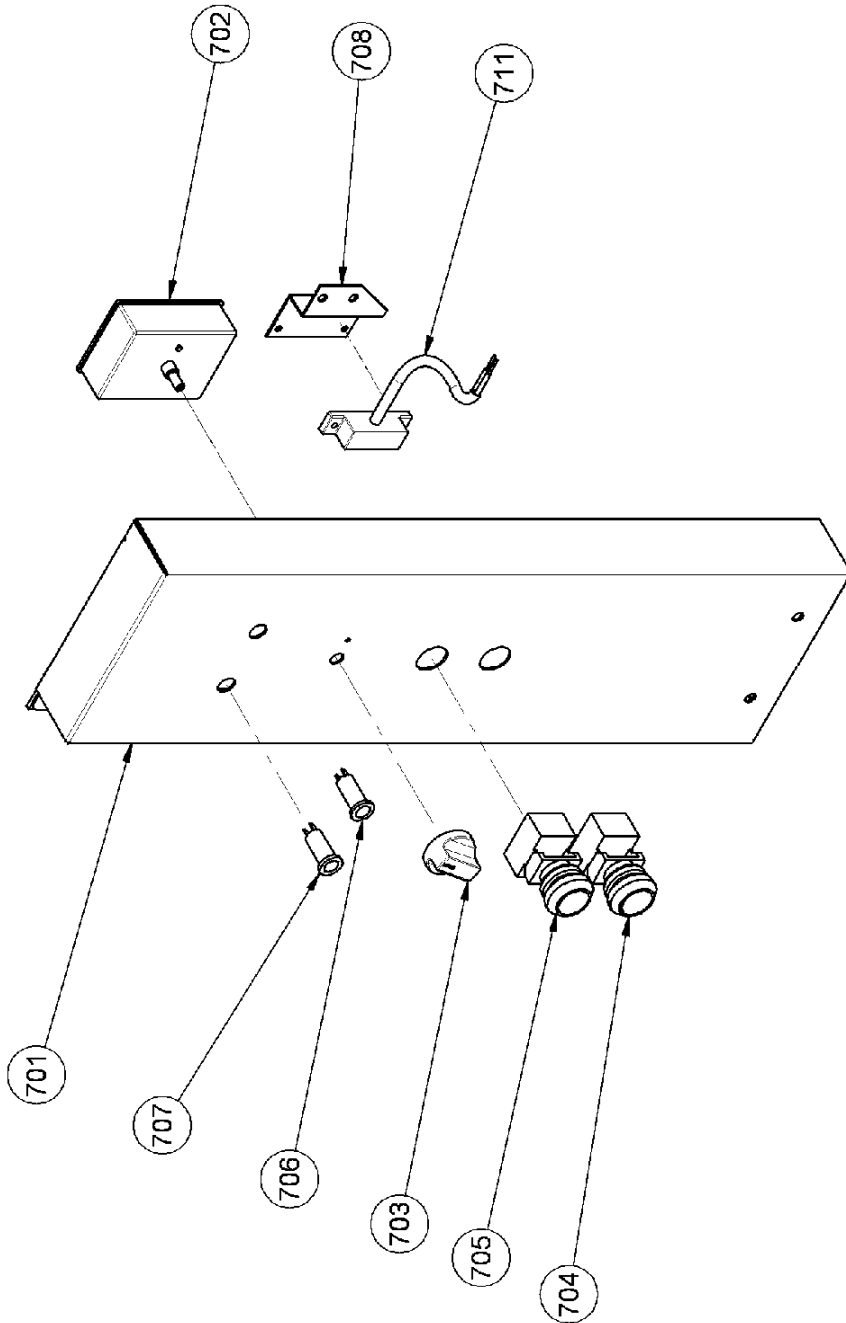

For Service Parts Call Oliver Products @ 800-253-3893



MODEL 688-N

**FRONT CONTROL PANEL PARTS LIST**

<b>ITEM NO</b>	<b>PART DESCRIPTION</b>	<b>PART NUMBER</b>
701	Control Panel	0688-0011
702	Temperature Control	5712-0015
703	Knob	5759-2050
704	Red Pushbutton	5708-7805
705	Green Pushbutton	5708-7806
706	Red Pilot Light	5709-0017
707	Green Pilot Light	5709-0019
708	Proximity Switch Bracket	0690-0042
711	Magnetic Proximity Switch	5757-8819

For Service Parts Call Oliver Products @ 800-253-3893



MODEL 688-N

**ELECTRICAL SUB PANEL ASSEMBLY**

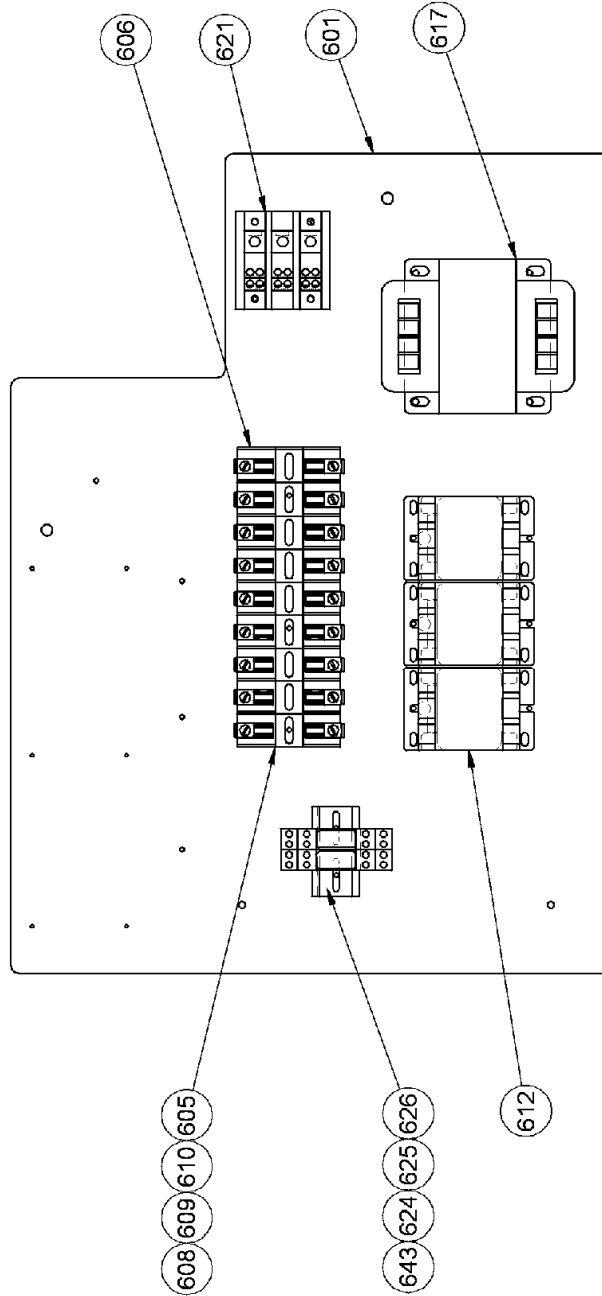

For Service Parts Call Oliver Products @ 800-253-3893  
Rev 8-30-05



MODEL 688-N

**ELECTRICAL SUB PANEL PARTS LIST**

<b>ITEM NO</b>	<b>PART DESCRIPTION</b>	<b>PART NUMBER</b>
601	Sub Panel	0691-0022
605	Add-On Fuse Block (208/240V)	5726-1080
605	Add-On Fuse Block (375/480V)	5726-1006
606	Add-On Fuse Block End Plate (208/240V)	5726-1089
606	Add-On Fuse Block End Plate (375/480V)	5726-1007
608	2 Amp Fuse (FRN-R-2)	5725-9614
609	4 Amp Fuse (FRN-R-4) (208/240V Ovens)	5725-9620
609	2 Amp Fuse (FNQ-R-2) (375/480V Ovens)	5725-9439
610	30 Amp Fuse (FRN-R-30) (208/240V Ovens)	5725-9634
610	15 Amp Fuse (KTKR-15) (375/480V Ovens)	5725-9066
612	Contactor	5749-8021
617	Transformer (208/375V Ovens)	5760-3195
617	Transformer (240/480V Ovens)	5760-3194
621	Terminal Block	5770-7463
624	Relay	5749-5675
625	Relay Clip	5749-5697
626	Relay Socket	5770-2832

For Service Parts Call Oliver Products @ 800-253-3893  
Rev. 8-30-05



MODEL 688-N

**REAR COVER ASSEMBLY**

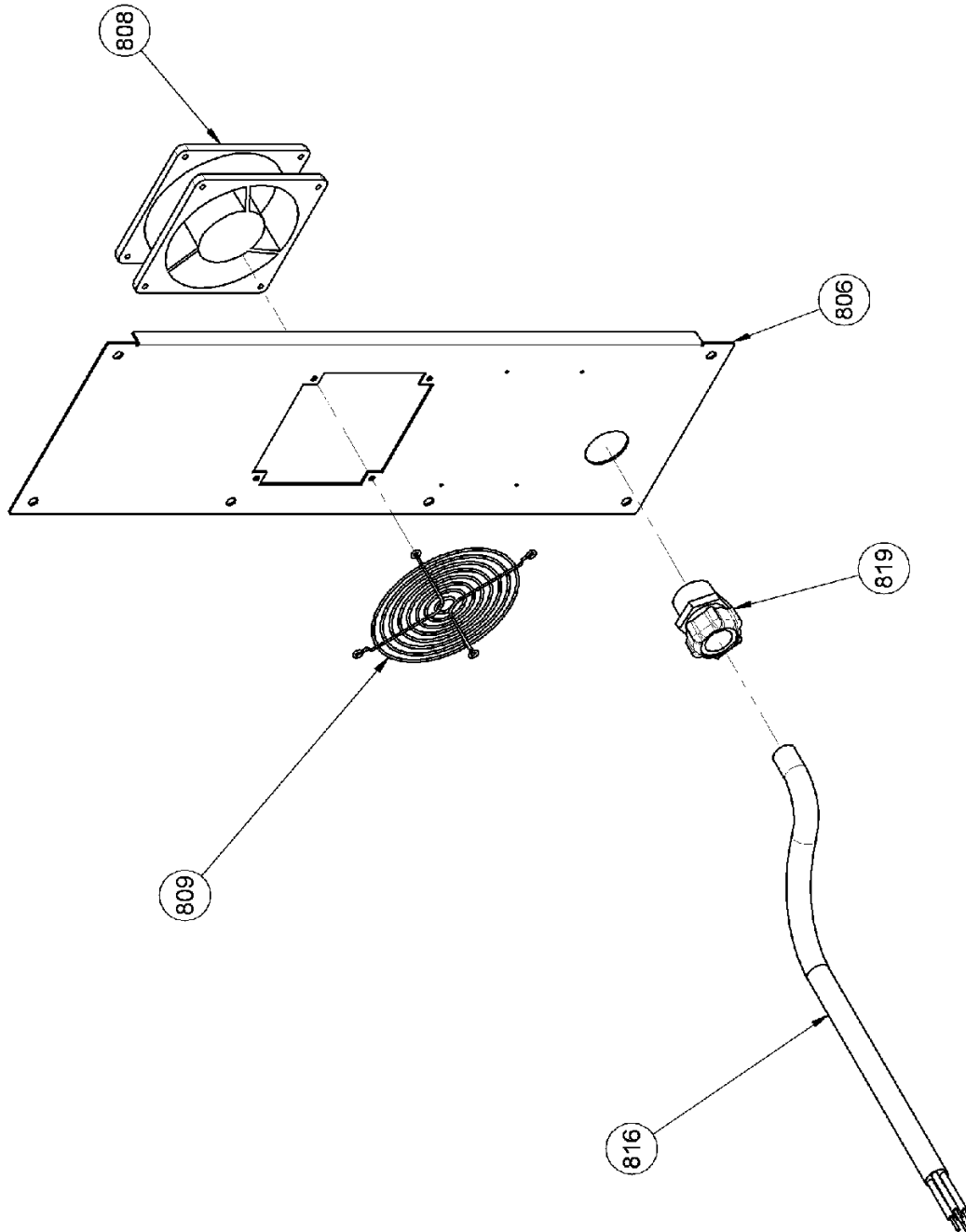

For Service Parts Call Oliver Products @ 800-253-3893



Oliver Packaging & Equipment Company  
511 Sixth Street NW • Grand Rapids, MI 49504

(800) 253-3893  
www.oliverquality.com

MODEL 688-N

### REAR COVER PARTS LIST

<b>ITEM NO</b>	<b>PART DESCRIPTION</b>	<b>PART NUMBER</b>
806	Rear Electrical Cover (208/240V Ovens)	0688-0012
806	Rear Electrical Cover (375/480V Ovens)	0688-0012-001
808	Axial Fan	6310-5027
809	Fan Grill	6310-5026
816	Power Cord (208/240V/3ph Ovens) 10 Ft.	5765-8342
816	Power Cord (375/480V/3ph Ovens) 10 Ft.	5765-8323
819	Strain Relief (208/240V Ovens)	5770-4822
819	Strain Relief (375/480V Ovens)	5770-4820

For Service Parts Call Oliver Products @ 800-253-3893  
Rev 8-30-05





MODEL 688-N

**COVER ASSEMBLY**

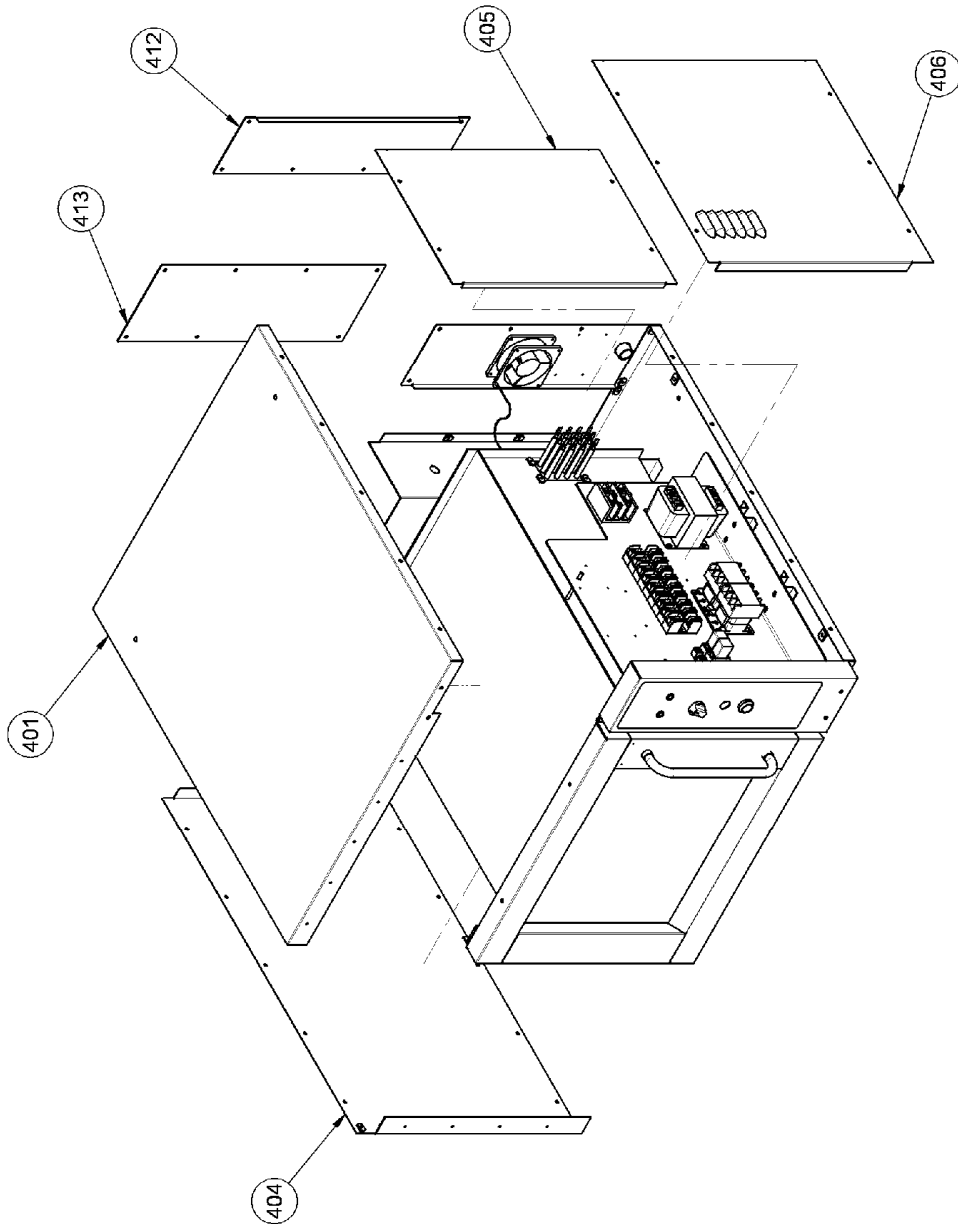

For Service Parts Call Oliver Products @ 800-253-3893  
Rev 8-30-05



Oliver Packaging & Equipment Company  
511 Sixth Street NW • Grand Rapids, MI 49504

(800) 253-3893  
www.oliverquality.com

MODEL 688-N

### COVER ASSEMBLY PARTS LIST

<b>ITEM NO</b>	<b>PART DESCRIPTION</b>	<b>PART NUMBER</b>
401	Top Cover	0688-0009
404	Hinge Side Cover	0688-0010
405	Electrical Side Rear Cover	0691-0016
406	Electrical Side Front Cover	0691-0017-001
412	Center Rear Cover	0691-0018
413	Right Rear Cover	0691-0019

For Service Parts Call Oliver Products @ 800-253-3893  
Rev 8-30-05



MODEL 688-N

3 Phase 208/240/375/480V WIRING DIAGRAM #0688D12002

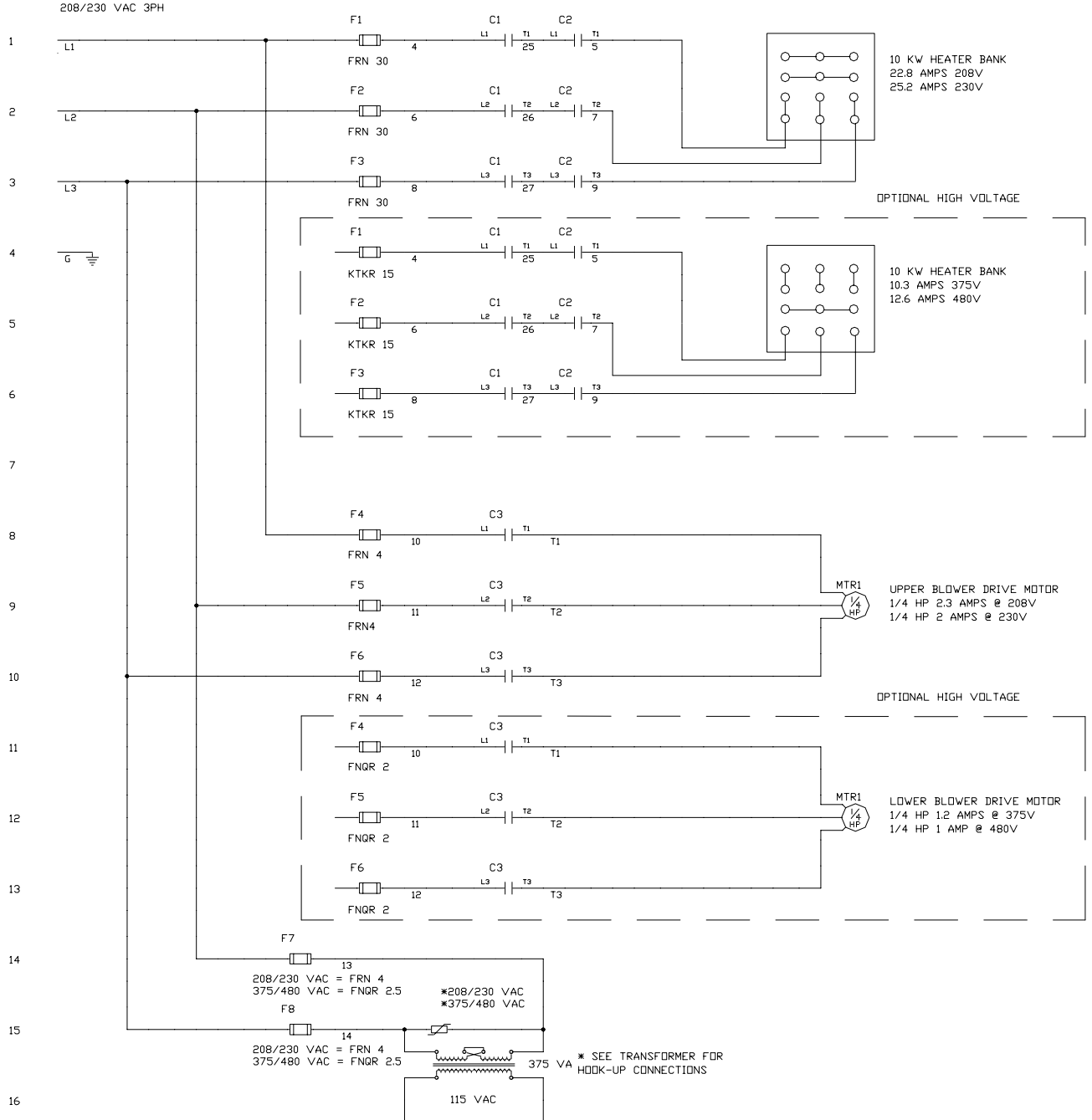

For Service Parts Call Oliver Products @ 800-253-3893



MODEL 688-N

3 Phase 208/240/375/480V WIRING DIAGRAM #0688D12002 (continued)

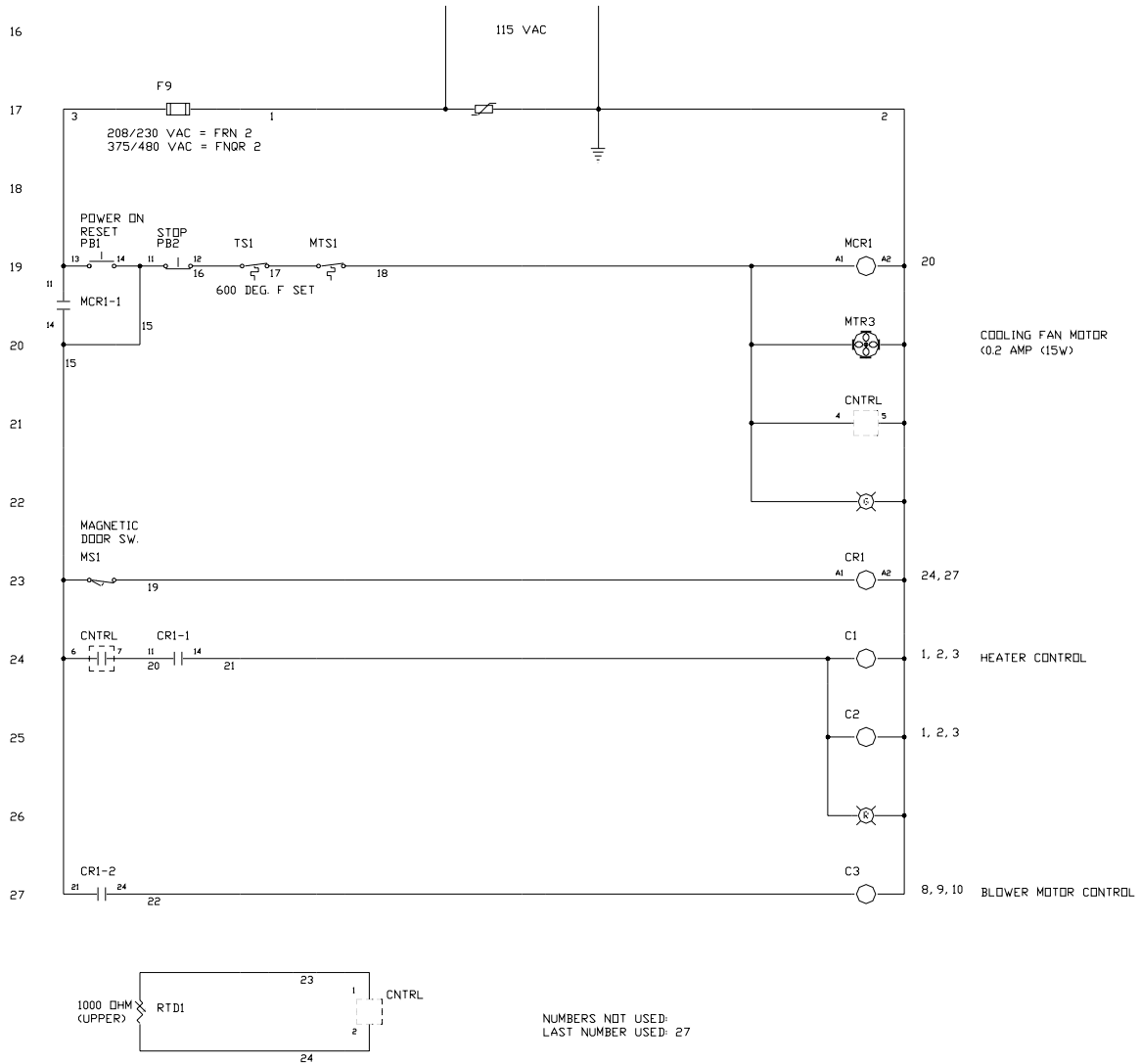

For Service Parts Call Oliver Products @ 800-253-3893



## WARRANTY

### PARTS

Oliver Products Company (Oliver) warrants that if any part of the equipment (other than a part not manufactured by Oliver) proves to be defective (as defined below) within one year after shipment, and if Buyer returns the defective part to Oliver within one year, Freight Prepaid to Oliver's plant in Grand Rapids, MI, then Oliver, shall, at Oliver's option, either repair or replace the defective part, at Oliver's expense.

### LABOR

Oliver further warrants that equipment properly installed in accordance with our special instructions, which proves to be defective in material or workmanship under normal use within one (1) year from installation or one (1) year and three (3) months from actual shipment date, whichever date comes first, will be repaired by Oliver or an Oliver Authorized Service Dealer, in accordance with Oliver's published Service Schedule.

For purposes of this warranty, a defective part or defective equipment is a part or equipment which is found by Oliver to have been defective in materials workmanship, if the defect materially impairs the value of the equipment to Buyer. Oliver has no obligation as to parts or components not manufactured by Oliver, but Oliver assigns to Buyer any warranties made to Oliver by the manufacturer thereof.

This warranty **does not** apply to:

1. Damage caused by shipping or accident.
2. Damage resulting from improper installation or alteration.
3. Equipment misused, abused, altered, not maintained on a regular basis, operated carelessly, or used in abnormal conditions.
4. Equipment used in conjunction with products of other manufacturers unless such use is approved by Oliver Products in writing.
5. Periodic maintenance of equipment, including but not limited to lubrication, replacement of wear items, and other adjustments required due to installation, set up, or normal wear.
6. Losses or damage resulting from malfunction.

The foregoing warranty is in lieu of all other warranties expressed or implied AND OLIVER MAKES NO WARRANTY OF MERCHANTABILITY OR FITNESS FOR PURPOSE REGARDING THE EQUIPMENT COVERED BY THIS WARRANTY. Oliver neither assumes nor authorizes any person to assume for it any other obligations or liability in connection with said equipment. OLIVER SHALL NOT BE LIABLE FOR LOSS OF TIME, INCONVENIENCE, COMMERCIAL LOSS, INCIDENTAL OR CONSEQUENTIAL DAMAGES.



Oliver Packaging & Equipment Company  
511 Sixth Street NW • Grand Rapids, MI 49504

(800) 253-3893  
[www.oliverquality.com](http://www.oliverquality.com)

## **WARRANTY PROCEDURE**

1. If a problem should occur, either the dealer or the end user must contact the Customer Service Department and explain the problem.
2. The Customer Service Manager will determine if the warranty will apply to this particular problem.
3. If the Customer Service Manager approves, a Work Authorization Number will be generated, and the appropriate service agency will perform the service.
4. The service dealer will then complete an invoice and send it to the Customer Service Department at Oliver Products Company.
5. The Customer Service Manager of Oliver Products Company will review the invoice and returned parts, if applicable, and approve for payment.



Oliver Packaging & Equipment Company  
511 Sixth Street NW • Grand Rapids, MI 49504

(800) 253-3893  
[www.oliverquality.com](http://www.oliverquality.com)

## RETURNED PARTS POLICY

This policy applies to all parts returned to the factory whether for warranted credit, replacement, repair or re-stocking.

Oliver Products Company requires that the customer obtain a Return Material Authorization (RMA) number before returning any part. This number should appear on the shipping label and inside the shipping carton as well. All parts are to be returned prepaid. Following this procedure will insure prompt handling of all returned parts.

To obtain an RMA number contact the Repair Parts Department toll free at (800) 253-3893.

Parts returned for re-stocking are subject to a **RE-STOCKING CHARGE**.

Thank you for your cooperation,

Repair Parts Manager  
Oliver Products Company