



Walker, Michigan, U.S.A. 49534-7564

USER'S OPERATING AND INSTRUCTION MANUAL

MODEL 1908-12/17

AUTOMATED PACKAGING SYSTEM



INDEX

SAFETY.....	1908S20054.....	PG. 1-1
UNCRATING.....	1908S20055.....	PG. 2-4
QUICK SPECS.....	1908S20056.....	PG. 3-1
INTRODUCTION AND DESCRIPTION....	1908S20057.....	PG. 4-1
MACHINE PLACEMENT.....	1908S20058.....	PG. 5-1
TECHNICAL SPECIFICATIONS.....	1908S20059.....	PG. 6-2
MACHINE COMPONENTS.....	1908S20060.....	PG. 7-9
START-UP.....	1908S20061.....	PG. 8-3
OPERATING PROCEDURE.....	1908S20062.....	PG. 9-3
CLEANING AND MAINTENANCE.....	1908S20063.....	PG. 10-5
TROUBLE SHOOTING.....	1908S20064.....	PG. 11-3
MAINTENANCE CHECKLIST.....	1908S20065.....	PG. 12-1
PARTS LIST.....	1908S20066.....	PG. 13-1
ELECTRICAL.....	1908S20067.....	PG. 14-2
PNEUMATIC	1908S20068.....	PG. 15-1
MACHINE EXCHANGE PROGRAM.....	GEN 050815	
WARRANTY.....	GEN 050816	
WARRANTY PROCEDURE.....	GEN 050817	
RETURNED PARTS POLICY.....	GEN 050818	



SAFETY

Various safety devices and methods of guarding have been provided on this machine. Do not operate the machine with guards removed and do not tamper with safety devices. It is essential that machine operators and maintenance personnel observe the following safety precautions. Improper installation or operation of this equipment may cause injury to personnel or damage to equipment.

- Before operating the *OLIVER Model 1908-12/17 Lidder* read through this manual. Never allow an untrained person to operate this machine

WARNING

- **WARNING PINCH POINT:** Keep hands out of machine. Always be sure the machine has been unplugged from power before cleaning or servicing.



- **CAUTION HOT:** The heater cover and upper platen are very **HOT!** Caution must be used to protect yourself and others.

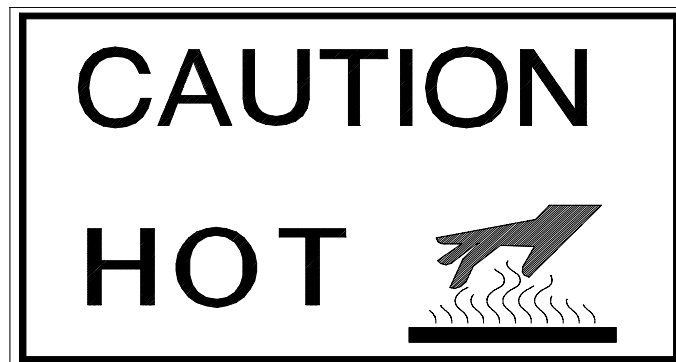

- In addition to these general safety instructions, follow the specific instructions given throughout this manual.



Oliver Packaging & Equipment Company
3236 WISON DR NW WALKER MI. 49534

(800) 253-3893
www.oliverquality.com

UNCRATING

MODEL 1908-12/17

Upon receipt and prior to uncrating, inspect the exterior of the crate for damage. If damage is noted, indicate damage on the Freight Bill and immediately contact the Freight Carrier and notify them of the damage. Have a freight claim filed. **This must be done at the Recipient's location and not at the Shipper's location.**

INSPECTION





Remove the boards from the skid by removing the nails that secure the boards to the skid. After removing all the boards from the Model 1908-12/17, inspect for visible damage. If damage is noted, immediately contact the freight company and file a Concealed Damage Freight Claim.

Remove the bands that hold the machine on the skid.

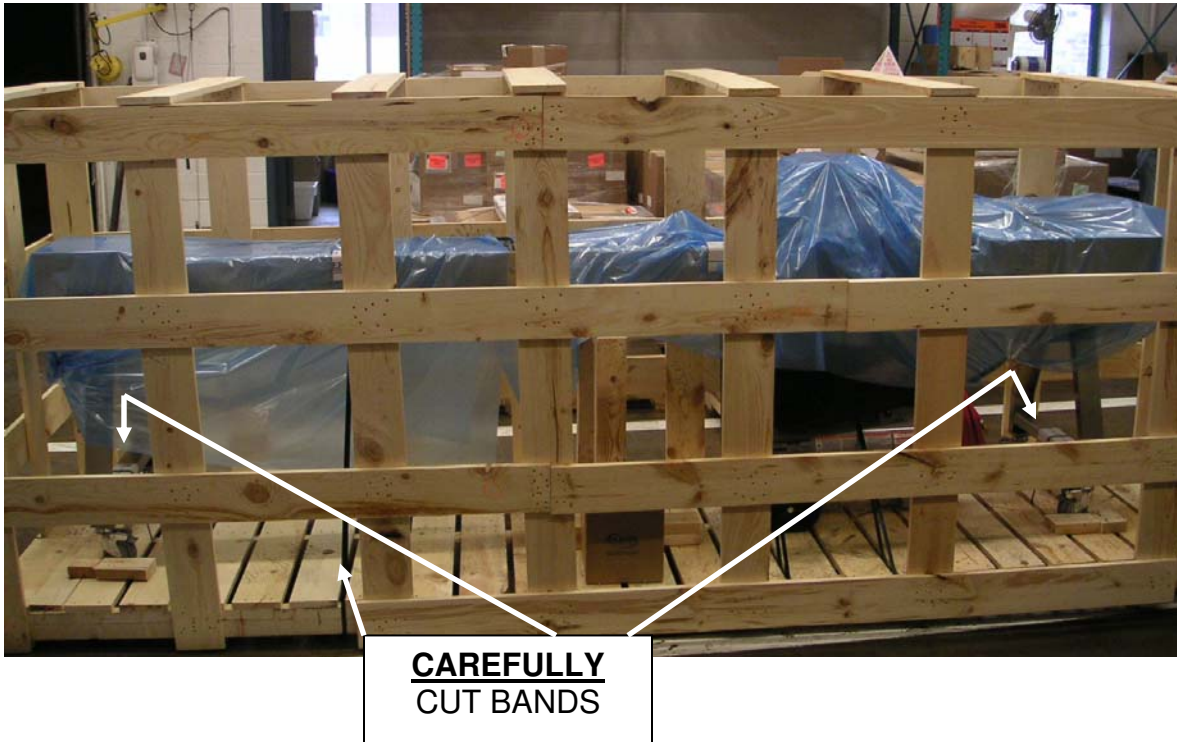



Remove the plastic ties that are securing the tray carriers to the conveyor. Use a side cutting pliers or large scissors to cut the plastic ties. A knife can be used but care must be exercised. Remove the padded packing materials.





Air Compressor

The air compressor is secured to the skid underneath the Model 1908-12/17. Remove the bands that hold the air compressor to the skid and carefully remove the air compressor from the skid.





QUICK SPECS

Weight 12ft	600 lbs
Weight 17ft	800 lbs
Overall Dimensions 12ft	30" W x 144" L x 50" H
Overall Dimensions 17ft	30" W x 204" L x 50" H
Loading Station 12ft	10 tray carriers
Loading Station 17ft	18 tray carriers
Discharge 12ft	3 tray carriers
Discharge 17ft	3 tray carriers

Both 12 and 17ft

Electrical	1 phase, 60 Hz, 115 VAC, 15 amps
Air Supply	90 PSI ± 10 PSI
Air Connector Size	1/4"
Air Compressor:	
Electrical	1 phase, 60 Hz, 115/230 VAC, 1.7 run HP, 13 GAL tank
Dimensions	16.625" W x 30.5" L x 33.75" H
Weight	60 lbs
Length of Air Hose	70 ft
Air Hose I.D.	3/8"



INTRODUCTION AND DESCRIPTION

The *OLIVER Model 1908-12/17 Lidder* has been designed and manufactured to provide a high quality machine that is a cost effective approach to producing film lidded trays. The machine can be operated with a 120 V.A.C. outlet. The Model 1908-12/17 is an automated system capable of producing a high volume, but it is easy to operate.

The machine consists of a conveyor system that transports the filled trays; a film feed system, a heated platen and a film cutter unit. These are all packaged together in a stainless steel framework that also houses all the necessary controls. The conveyor is intermittent motion and is capable of running speeds of 5 to 30 packages per minute. The system also includes an air compressor that is a separate unit that can be located remotely.

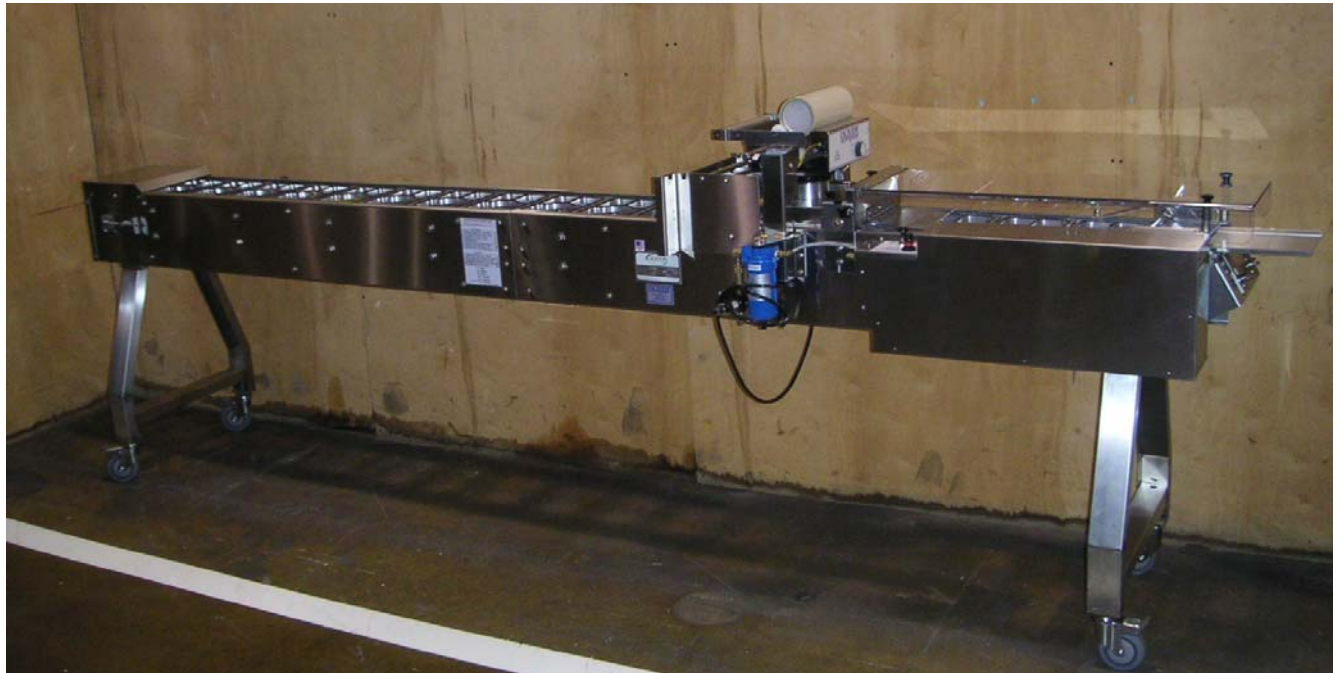



MACHINE PLACEMENT AND UTILITIES

MODEL 1908-12/17

Decide on a suitable location for the machine. This location should have ample room to work around all sides of the machine. Once the machine is in the location where it will be used, the brakes on the casters should be locked by stepping down on the brake locking lever. To unlock, lift the lever with your foot. Do not attempt to move machine with casters in locked position.



The machine operates on 120 V.A.C., 60 Hz, 15 Amp electrical power. It is recommended that this power be supplied by an overhead drop to prevent the cord from becoming a trip hazard.

The machine needs to be connected to compressed air. This is accomplished by connecting the machine to the air compressor supplied with the machine. This connection should be made using an overhead drop.



Oliver Packaging & Equipment Company
3236 WISON DR NW WALKER MI. 49534

(800) 253-3893
www.oliverquality.com

TECHNICAL SPECIFICATIONS

Model 1908-12/17

Tray Capacities: 6.50



Oliver Packaging & Equipment Company
3236 WISON DR NW WALKER MI. 49534

(800) 253-3893
www.oliverquality.com

AIR COMPRESSOR

Weight: 60 LBS.

Electrical: 115 VAC, 15 Amps, Single Phase, and 60 Hz

Length of Air Hose: 70 Ft.

Air Hose I.D.: 3/8



MACHINE COMPONENTS

Before proceeding further, take a moment to familiarize yourself with the identification of the machine components as shown in the illustrations below.

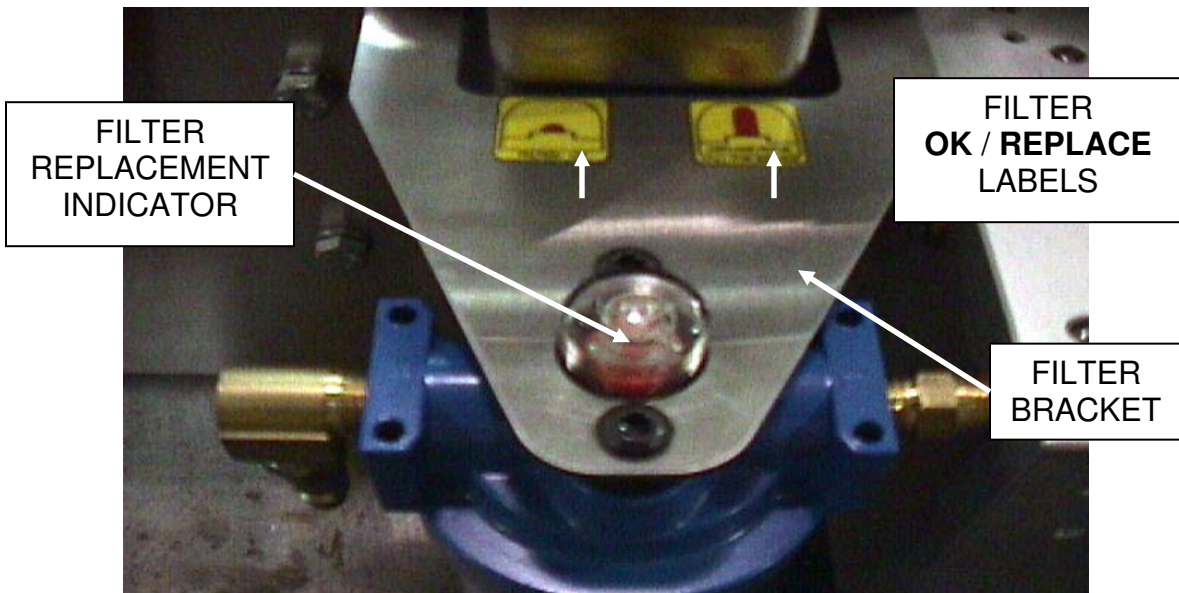

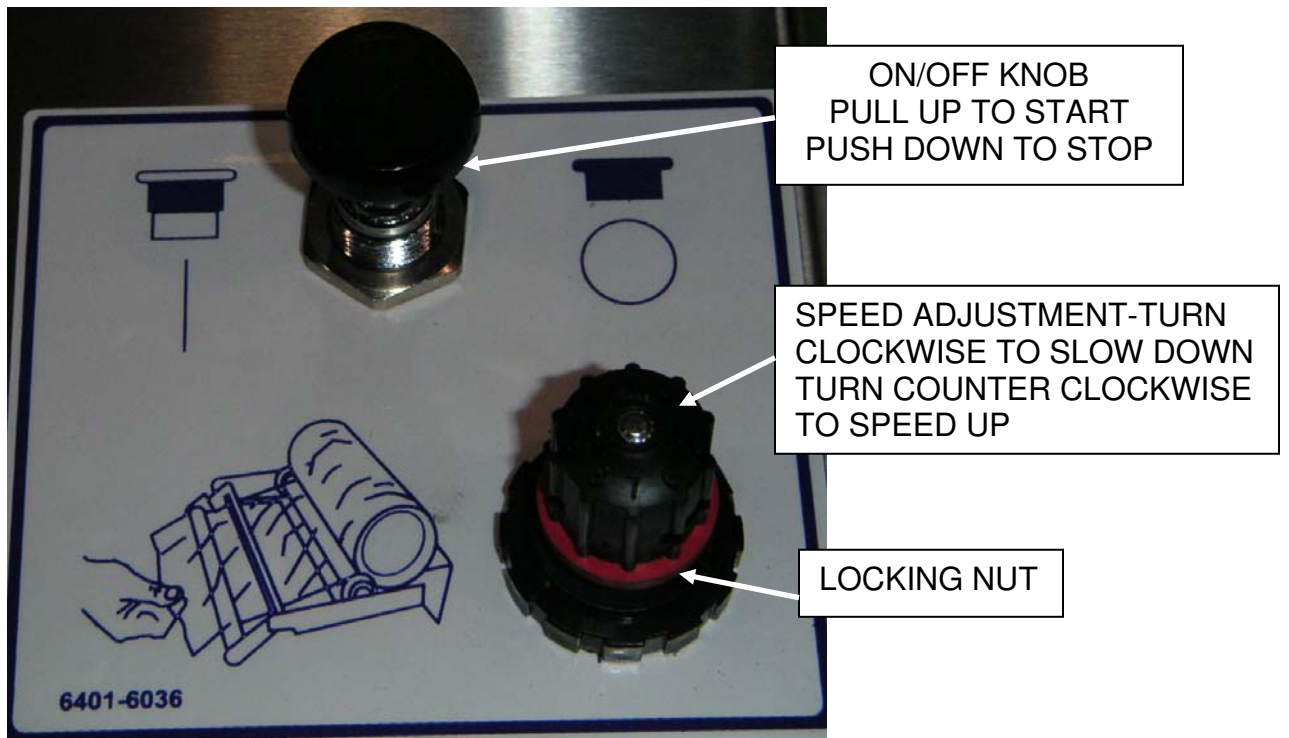

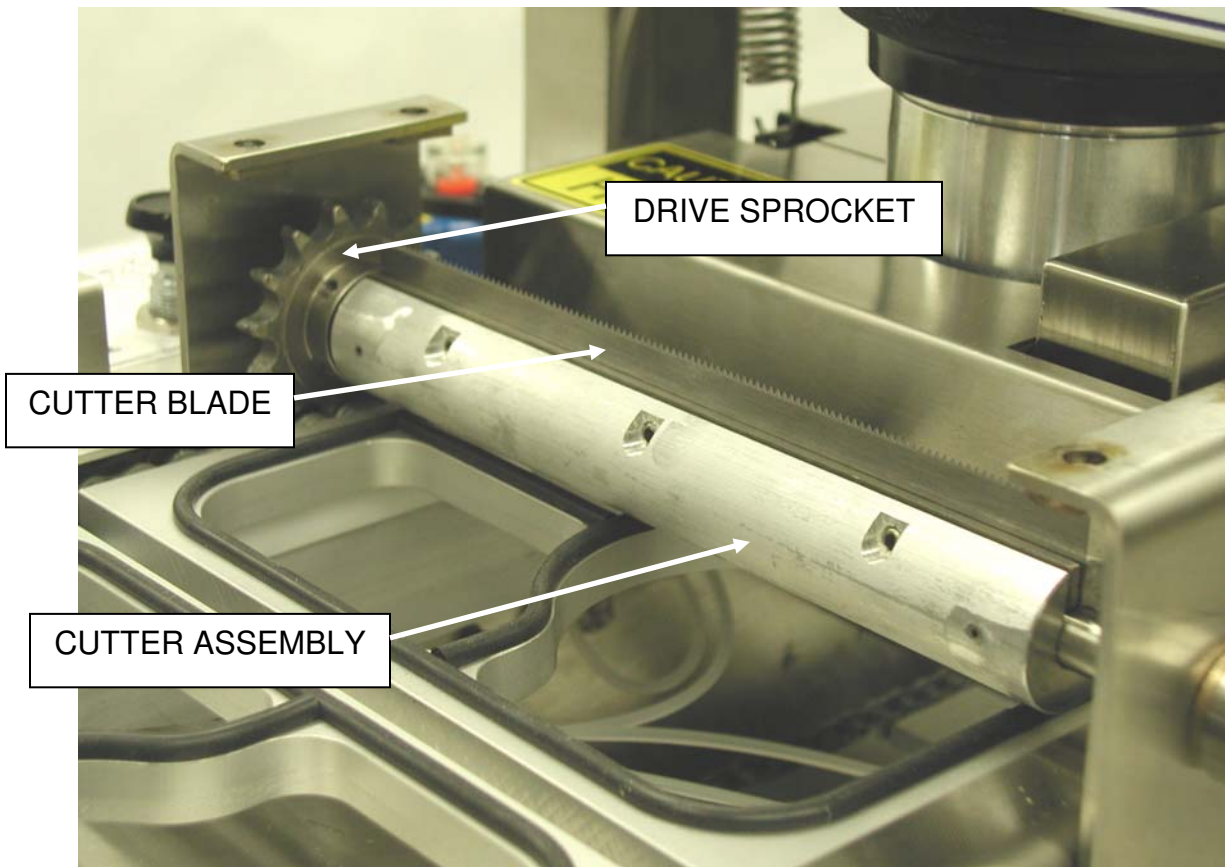
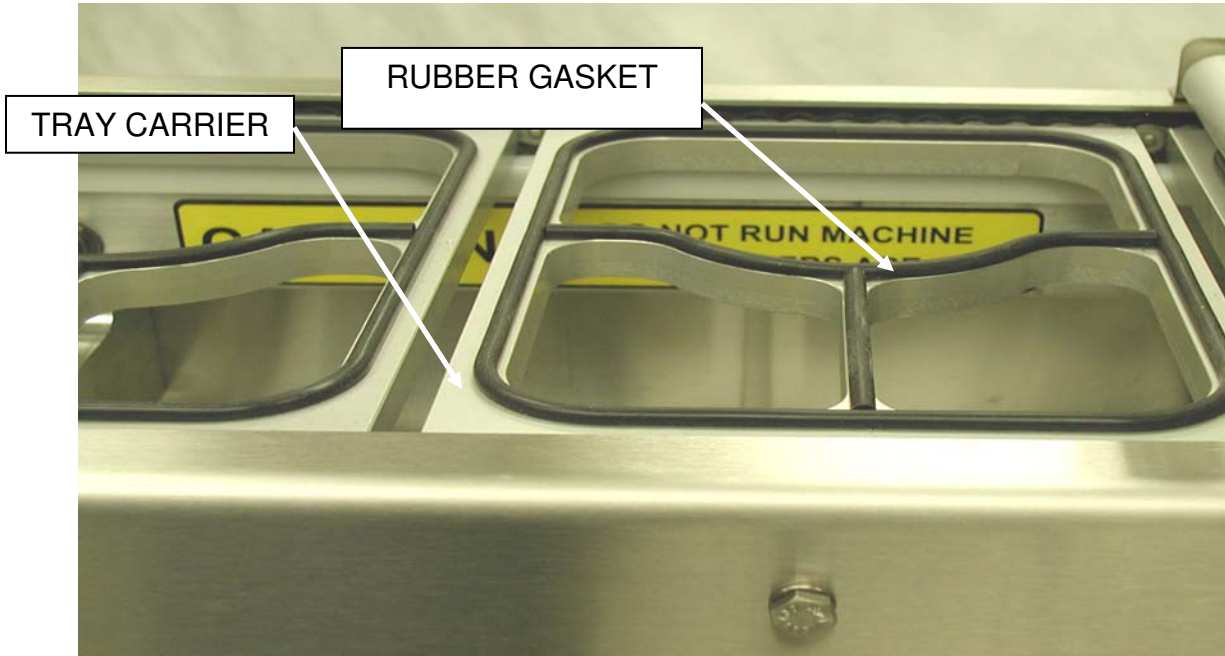

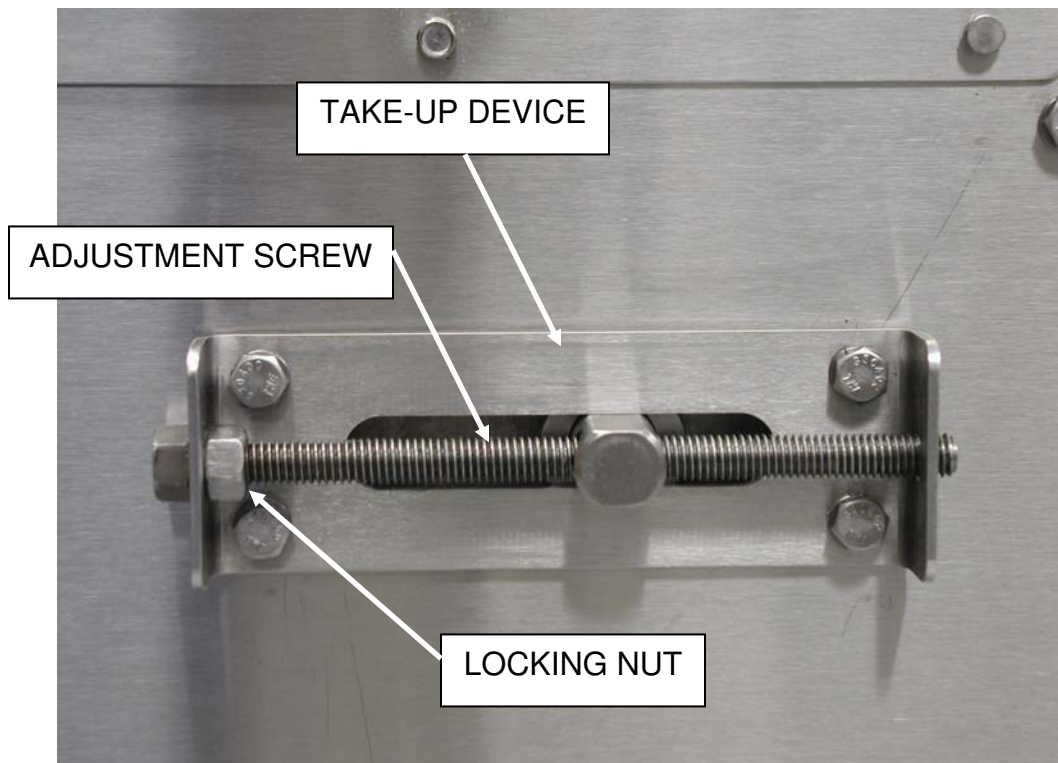
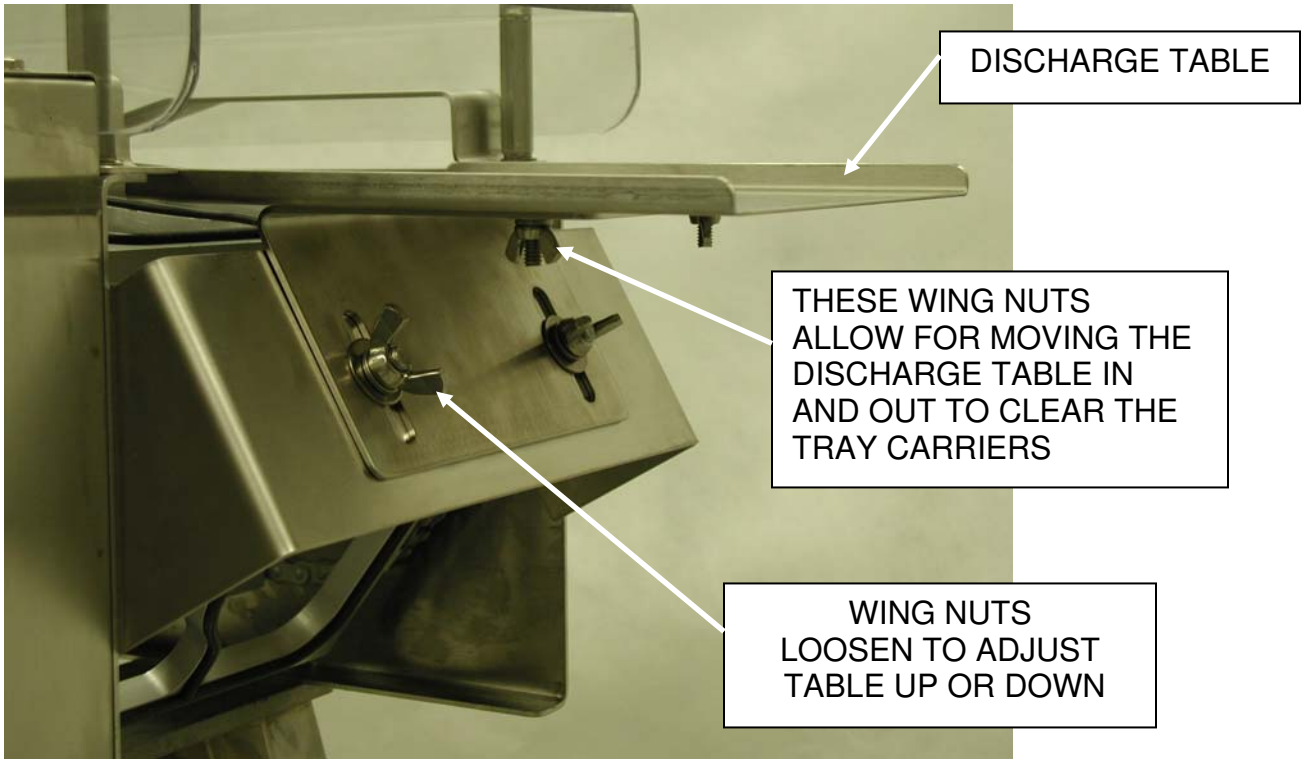

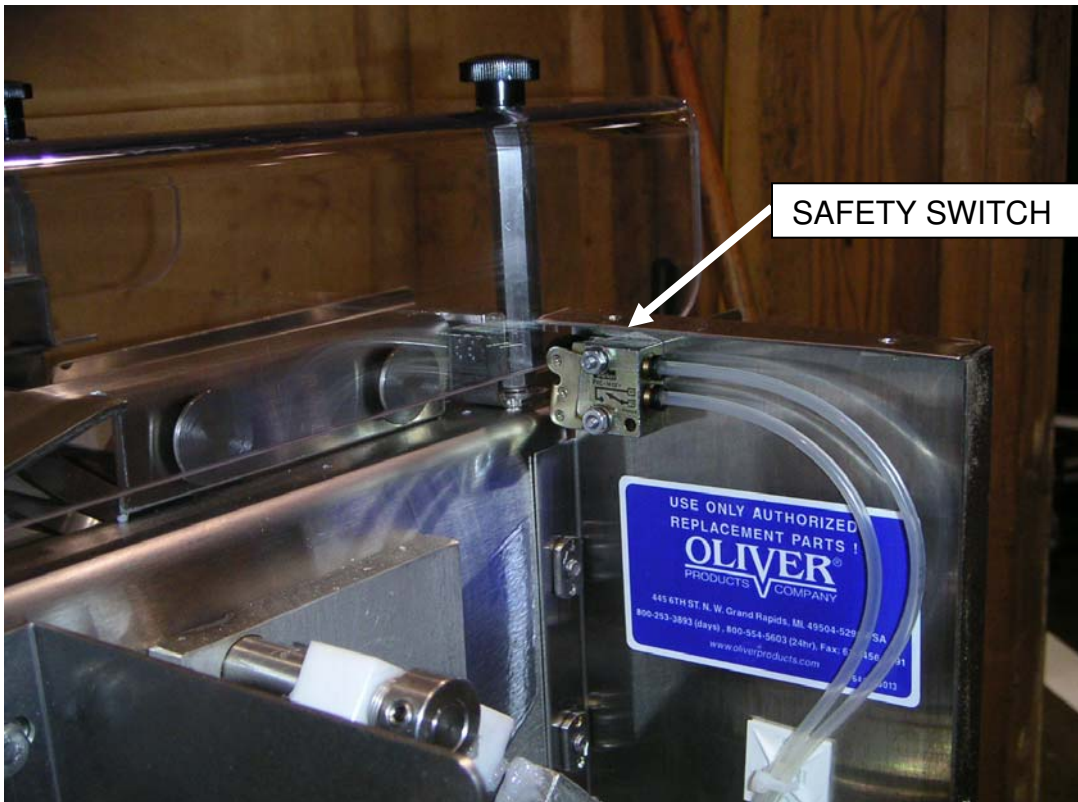



Air Compressor

Decide on a suitable location for the air compressor. It is best to locate it out of the way and preferably where the noise will not be a factor. The air compressor operates on 120 V.A.C., 60 Hz, 15 Amp electrical power. The air compressor is supplied with a 70 ft. length of 3/8" ID air hose that needs to be connected between the air compressor and the Model 1908-12/17. This air hose has quick-disconnect fittings at both ends for easy connection and disconnection. Pull the collar back on the female portion of the quick-disconnect fitting and then push the female portion onto the male portion and release your hand. Pull on the hose to make sure the connection is secure.

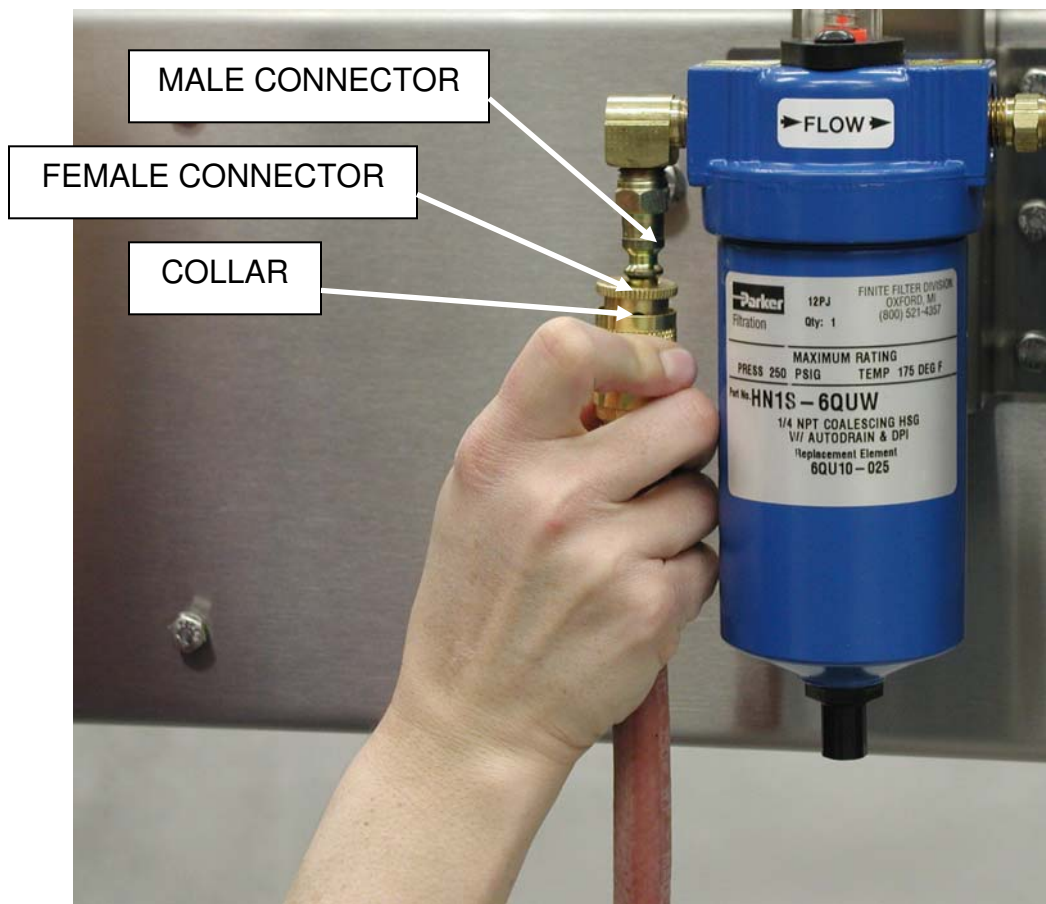

Continued



Air Compressor Continued

The air compressor has been factory set. If for some reason the settings are not correct, the following procedure should be followed to set the output pressure from the compressor.

The gage shown below should be set at 90 PSI. This is accomplished by turning the knob on the regulator clockwise to increase pressure or counter clockwise to decrease pressure. It is recommended that the air compressor be left with the switch in the "AUTO" position. The compressor will only run when there is a demand for air when it is set in the "AUTO" position. Leaving the switch in this position assures that the compressor will be ready when it is needed.

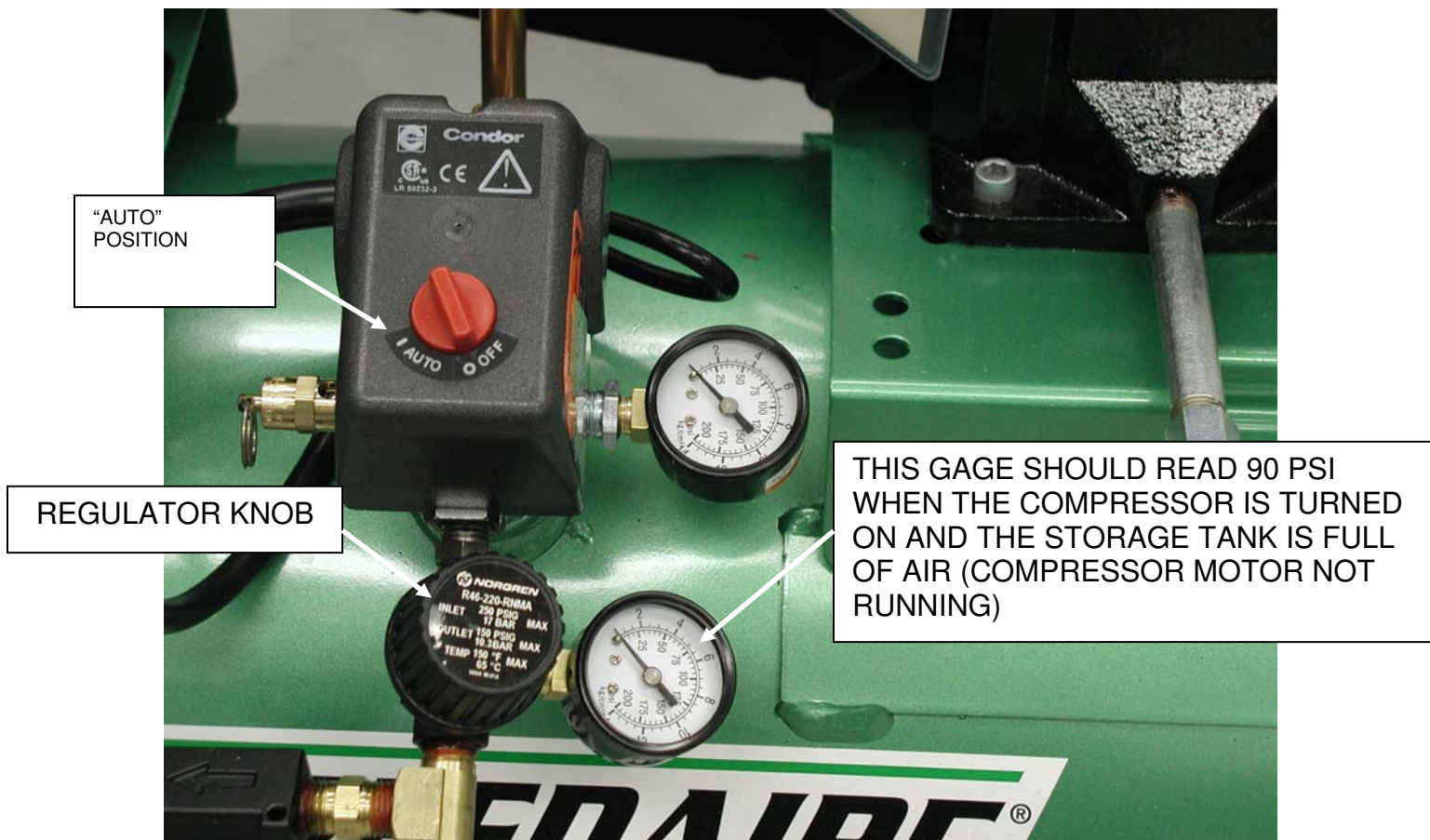



START-UP

To turn the machine on, plug in the power cord. Wait 30 minutes to allow the heated platen to reach operating temperature. At this time, turn on the air compressor so it can fill the storage tank with compressed air.

Depending on your production rates, you may need to speed up or slow down the tray sealer. This adjustment is explained in the “Machine Operation” section of the manual. First, run the machine without trays and film to make sure everything is cycling properly.

NOTE

- Never run the machine with trays and no film. Doing so can possibly cause a jam because the trays can stick to the heated platen and be pulled out of the tray carriers.

Load the film on the film stand as shown on the film-threading diagram located on the side of the machine and also shown in the diagram below.

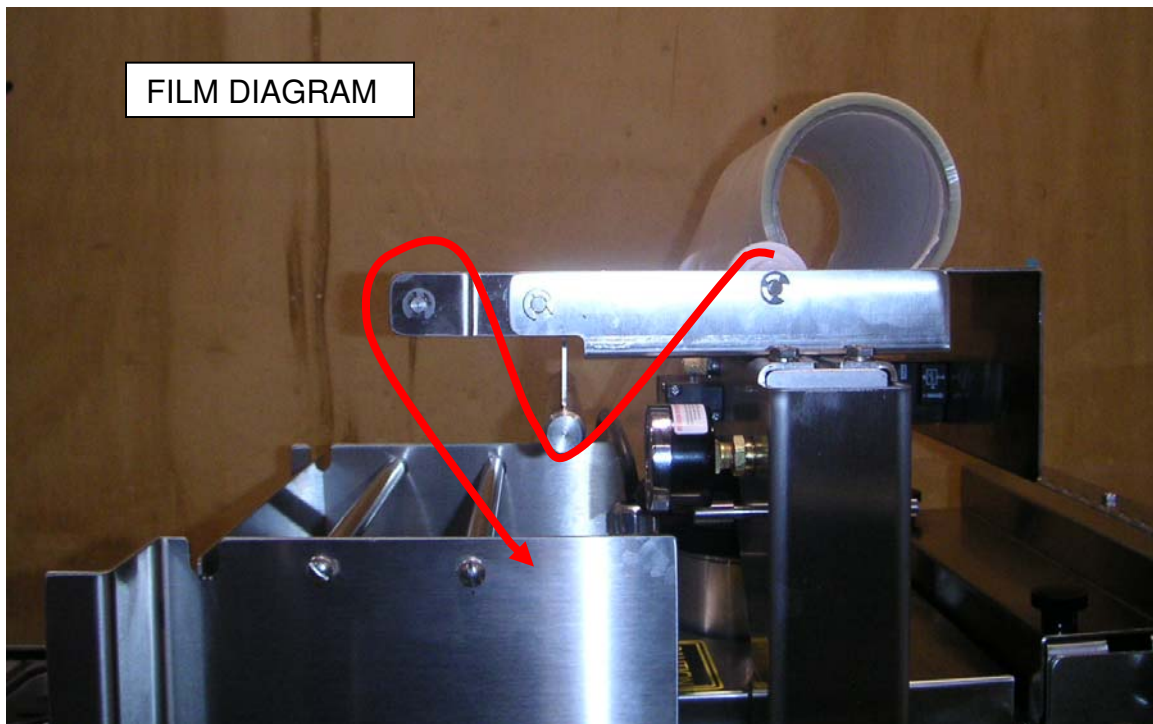



NOTE

1. The adhesive side of the film can be determined by pinching a fold and rubbing the lid material against itself. Test both sides of the lid. The rough or tacky side of the lid will be the adhesive side. The film supplied by Oliver Products Company is wound with the adhesive side toward the inside of the roll. If the film is loaded in accordance with the **“FILM FEED”** diagram it will be positioned properly for applying the adhesive side of the film to the flange of the tray. If the film is loaded improperly, it can cause the adhesive side to come in contact with the heated platen and the film to stick to the heated platen. If this happens, the platen will need to be cleaned.
2. To thread the film remove safety door then thread the film through the machine, pull enough film off the roll so that you can insert it into the slot between the tray carrier that is partially under the film stand and the carrier that is upstream from that. After the film is hanging down underneath the tray carrier. Then insert a tray into the tray carrier next to the film and cycle the machine one time by pulling up on the **“Black Palm Button”** until the conveyor moves one index, then push the palm button down to stop the machine. This should seal the film to that tray and you can now fill the rest of the conveyor with filled trays and begin running.

Note: Film dancer bar must move freely up and down.

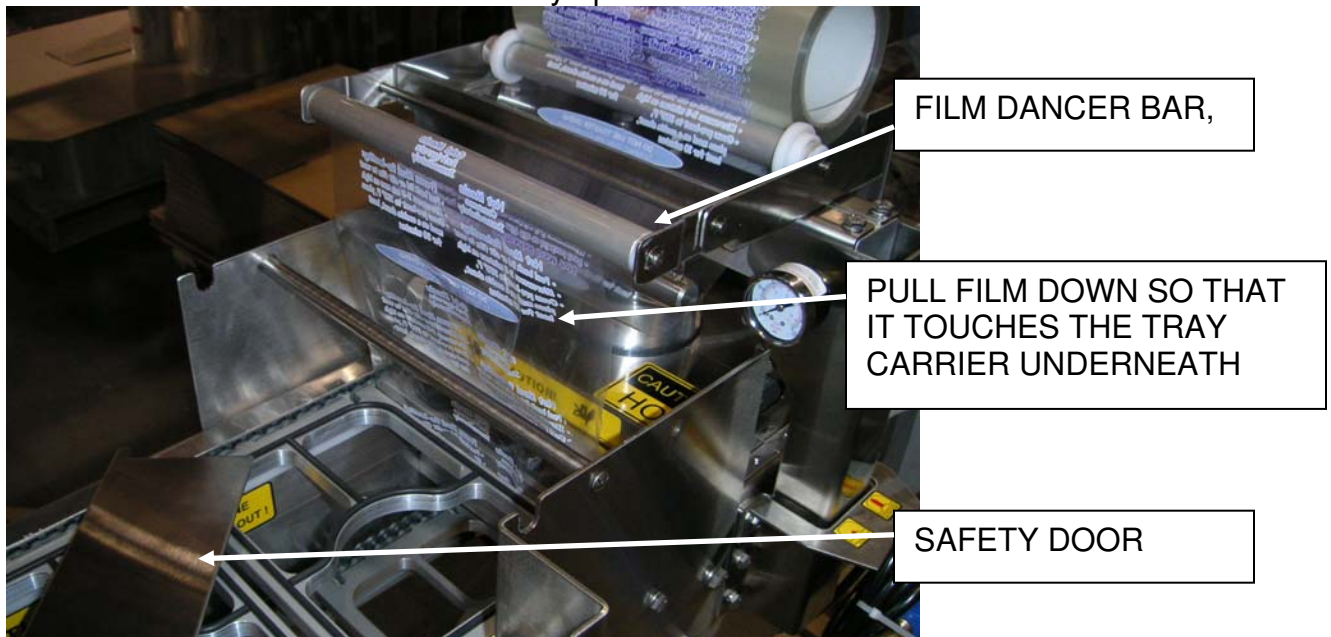

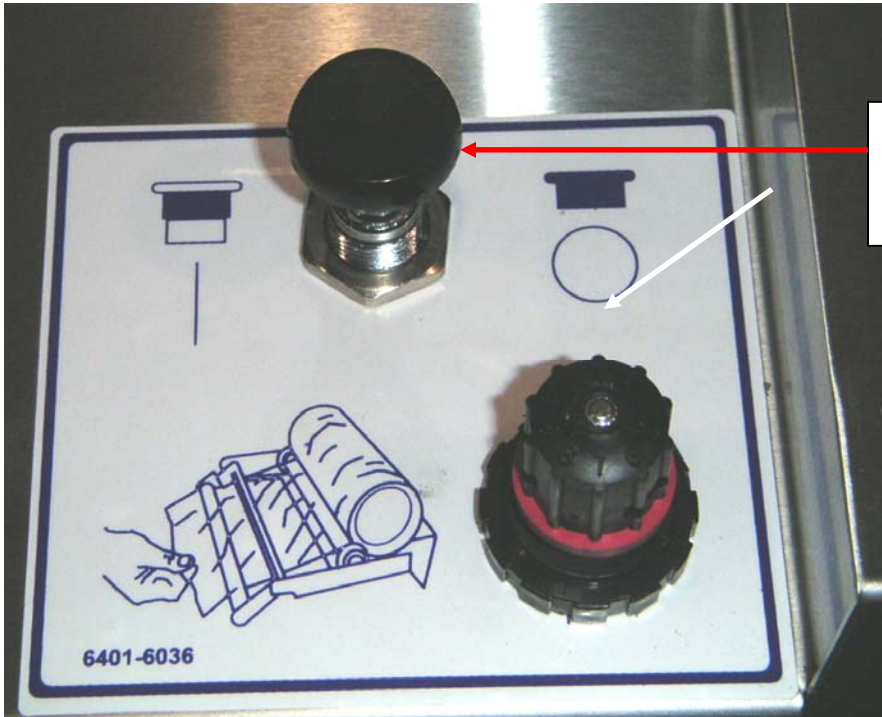

MAIN-ON/OFF KNOB
PULL UP TO START
PUSH DOWN TO STOP



2nd-ON/OFF KNOB
PULL UP TO START
PUSH DOWN TO STOP

Note: Both knobs must be in the up position to run. Which ever location that shuts the machine off must be the same location to start it back up.



OPERATING PROCEDURE

An abbreviated version of these operating procedures is attached to the Model 1908-12/17 for use as a daily reference.

If you miss putting a tray in the machine it will not cause any problems, but the film will be sealed to the top of the empty tray carrier. Let the machine continue to run until that tray carrier goes around the bottom of the conveyor and comes back up on top, then remove the piece of film.

Once you have settled into a fairly consistent production rate, adjust the machine speed to match your production rate as close as possible and lock the speed adjustment knob with the locknut.

To operate the Model 1908-12/17, plug in the power cord. Wait 30 minutes to allow the heated platen to reach operating temperature. Turn on the air compressor.

1. Load a roll of film onto the film support stand as shown on the "FILM FEED" diagram located on the side of the machine. It is important that the roll of film is centered on the conveyor. There are white plastic film guides on either side of the film roll. These guides can be adjusted from side-to-side by pushing them with your hand. If the film is not centered, move both guides toward the side that the film needs to go to. It may take a little bit of running time before you can tell if the film is in the correct position.
2. To get the film threaded through the machine, pull enough film off the roll so that you can insert it in the slot between the tray carrier that is partially under the film stand and the carrier that is upstream from that. After the film is hanging down underneath the tray carrier. Then insert a tray in the tray carrier next to the film and cycle the machine one time by pulling up on the "**Black Palm Button**" until the conveyor moves one index, then push the palm button down to stop the machine. This should seal the film to that tray and you can now fill the rest of the conveyor with the filled trays and begin running.
1. Place filled trays in tray carriers. Take care to avoid spilling food product on the flange of the tray. Contamination of the flange can result in poor heat seals.



NOTE

- Never run the machine with trays and no film. Doing so can possibly cause a jam because the trays can stick to the heated platen and be pulled out of the tray carriers.
2. Pull the black palm button up to start the machine running. After a few trays come out of the machine, stop and check to see that the seals are acceptable. Poor seals may be caused if the dwell time of heated platen is set too short. The machine was shipped from the factory with the dwell time set properly. However, it could have come out of adjustment during shipment. The 0.1-3 second dwell time adjustment knob should be set with indicator arrow between the letter “**B & C**” as shown in the illustration below. Do not turn the knob so that the indicator arrow goes past the letter “**F**” and before the letter “**A**”. The closer the indicator arrow is to the “**A**”, the shorter the dwell time.



3. Once you are running at a constant rate, set the speed of the machine to match your production rate. This is done by turning the “**Speed Adjustment**” knob clockwise to slow the machine down or



- counterclockwise to speed the machine up. A locking nut is provided on the speed adjustment knob that can be used to lock the speed adjustment after you have found the desired setting.
4. Make certain that the sealed trays are discharging off the end of the machine smoothly. If they are not, raise or lower your accumulating table or conveyor to allow for a smooth discharge of the trays. The discharge table on the Model 1908-12/17 has a height adjustment. The discharge table should be set at the proper height so that the bottoms of the trays are just slightly above it as they leave the tray carriers.

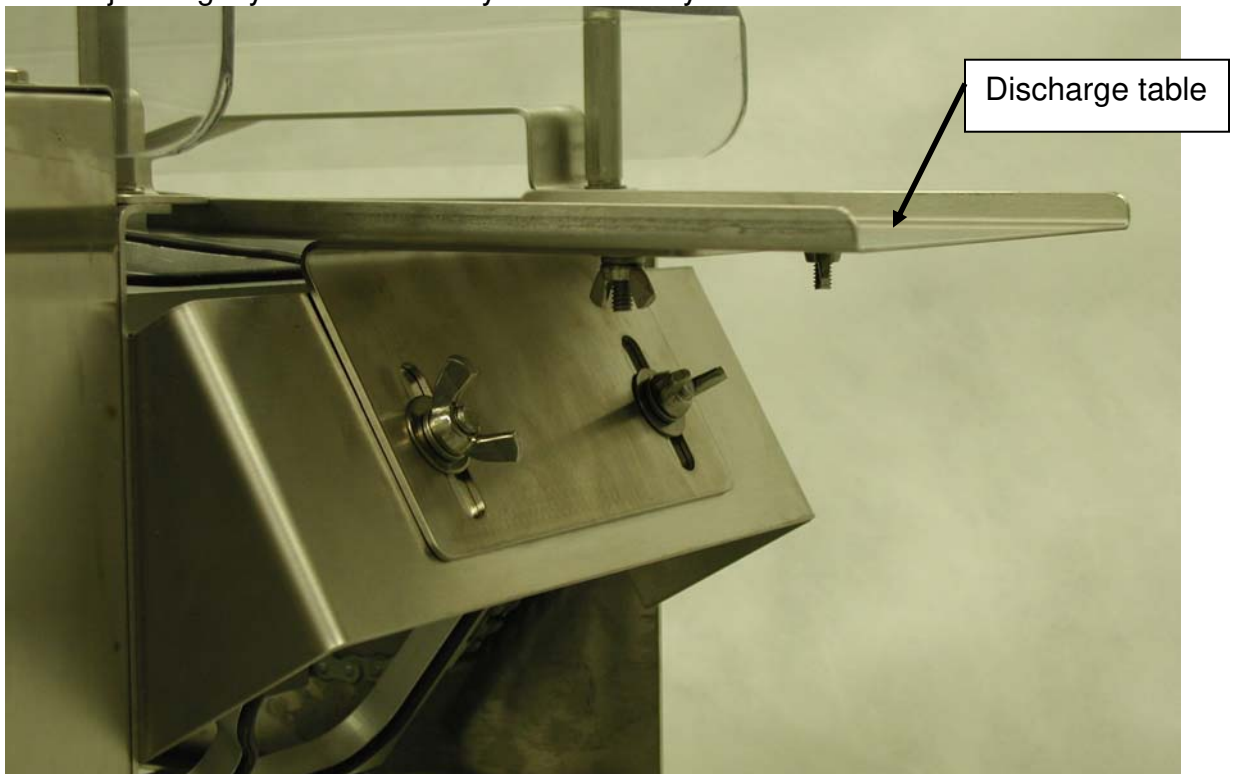

5. At the end of the day, unplug the Model 1908 from the wall outlet. This is the only way to turn off the machine.

NOTE

- **IT IS NOT RECOMMENDED TO LEAVE THE MACHINE PLUGGED IN WHEN IT IS GOING TO BE OUT OF OPERATION FOR AN EXTENDED PERIOD OF TIME.**



CLEANING AND MAINTENANCE

Disconnect the power from the Model 1908-12/17 and allow the unit to cool before cleaning. The tray carriers should be removed and cleaned daily. It is better to remove them for cleaning rather than trying to clean them in the machine. The tray carriers can be placed in your dishwasher for cleaning if you desire. Care should be taken so that the rubber gaskets do not become damaged.

CAUTION

- Do NOT run the machine with the tray carriers removed. Doing so could cause damage to the heat seal assembly.

The diagram on the next page shows how to remove the tray carriers. It is a simple process that just requires lifting up on the tray carrier and shifting it over to one side while pulling the carrier next to it to the other side to disengage the pins on the opposite side and then completely removing the carrier as shown. The carriers should be removed in the middle of the in-feed area on the top of the conveyor. As the carriers are removed, the conveyor must be pulled forward to keep getting to the remaining carriers. To move the conveyor forward, grasp a tray carrier toward the infeed-end of the machine and pull the conveyor forward. This must be done with the air connected.

NOTE

- When replacing the tray carriers, it is extremely important to make sure that all four pins on the conveyor chains are fully engaged in the holes of the tray carrier. If the tray carriers are put in on an angle because the pins are not engaged on one side, it could cause damage to the cutter assembly.



REMOVING TRAY CARRIERS



NOTE

- These cleaning recommendations are not meant to replace or supersede plant-standard manufacturing procedures or regulatory requirements.
- If the machine has been operating, allow the unit to cool before cleaning.

CAUTION

- **CAUTION HOT:** The heater cover and upper platen are very **HOT!** Care must be taken to protect yourself and others.

WARNING

- Make sure the unit has been unplugged from power.

Clean the OLIVER Model 1908-12/17Lidder with a mild cleaner or sanitizing solution and a damp cloth. It is important that the surface of the heated platen be kept clean and smooth. If food product comes in contact with the surface of the platen it tends to burn on and become hard. This results in an irregular surface



on the face of the platen that can result in poor seals. If this happens, it will be necessary to remove this burnt on food material. When cleaning the surface of the platen care must take to avoid scratching or gouging the surface. **DO NOT SCRAPE THE SURFACE OF THE PLATEN WITH SHARP OBJECTS AND AVOID THE USE OF METAL TOOLS.** Instead use a plastic or soft-metal scouring pad such as Scotch Brite® or Chore Boy® brands provide a safe and effective means of cleaning the heated platen. Wipe all surfaces with a sanitizing agent after cleaning.

WARNING

- If the platen will be cleaned while it is still hot make sure hand protection is used to prevent skin contact with the platen.
- The heat seal platen needs to be cleaned to remove food deposits. This must be done while the tray carriers are removed from the machine.

WARNING

- Disconnect and Lock out air supply / Electrical cords before performing maintenance. The cutter assembly is very sharp!

Clean the cutter assembly with a mild cleaner or sanitizing solution and a damp cloth

NOTE

- The use of plastic or soft-metal scouring pads such as Scotch Brite® or Chore Boy® brands provide a safe and effective means of cleaning the cutter assembly. Wipe all surfaces with a sanitizing agent after cleaning.

Once a month the conveyor chains should be lubricated with vegetable oil. If you use hose-down cleaning, this should be done twice a month.



Once a month the conveyor chains should be checked for proper tension. The tension can be checked by lifting the lower tray carriers 4 ft from the adjustment end. If you can easily lift them up more than 4 inches, the chains are too loose and should be tightened by adjusting the chain tensioner units at the infeed-end of the machine. Loosen the locking nuts and turn the adjusting screws clockwise to tighten the chains then retighten the locking nut. It is important to adjust both sides equally. The easiest way to do this is to count the turns that you tighten one side and then do the same on the other side. The best method is to adjust each side in $\frac{1}{4}$ turn increments and then recheck the chain tension.

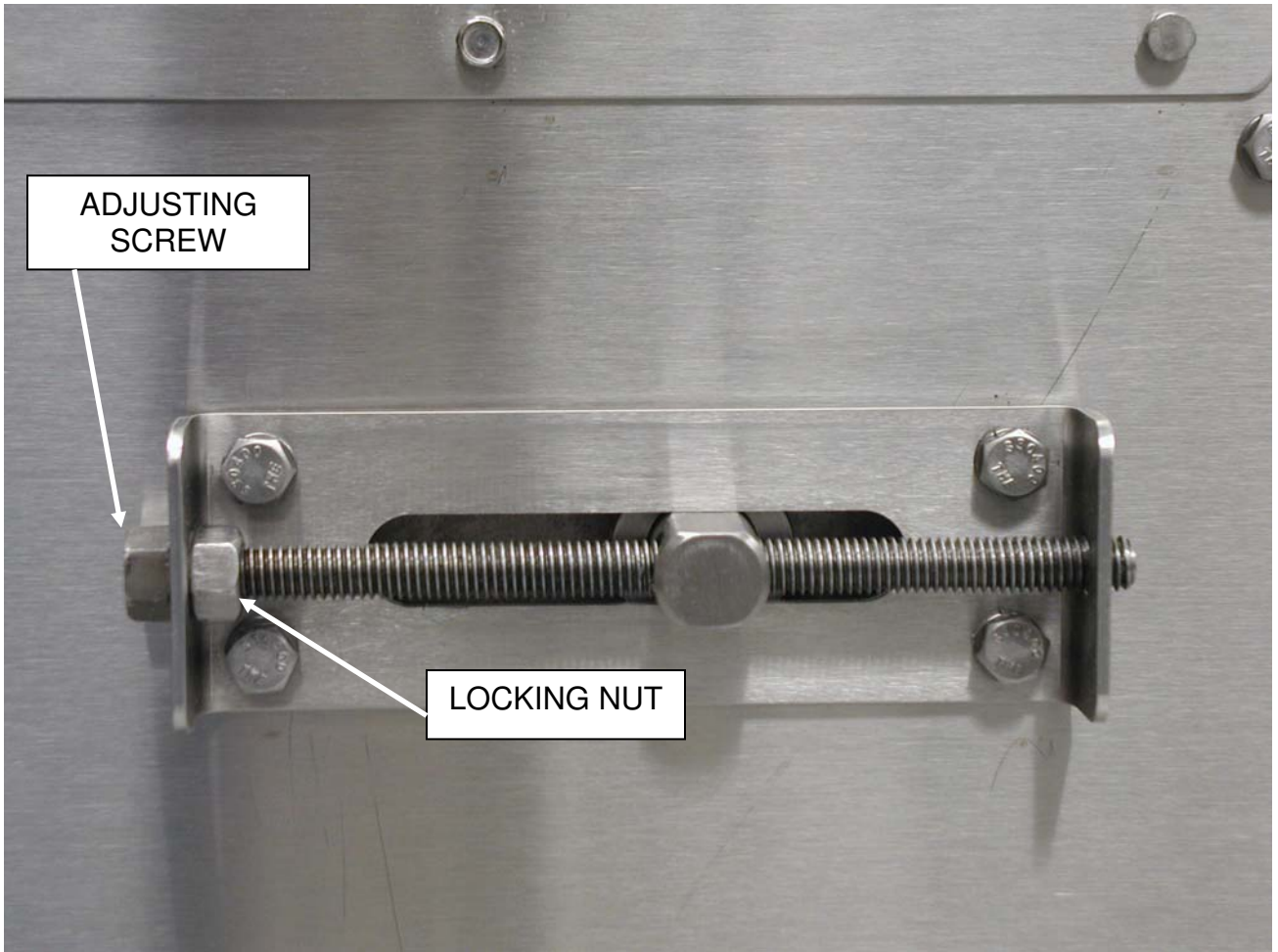



TROUBLESHOOTING

Should you experience problems with your machine call the **Oliver Products Company 24 Hour Emergency Service number @ 1 800-253-3893. Please have the serial number of your machine available to give to the Customer Service representative.**

Before calling for assistance please check the list below to see if the problem you are experiencing is listed. If it is, try the corrective action items listed for that problem before calling for assistance.

<u>SYMPTOM</u>	<u>CORRECTIVE ACTION</u>
Machine does not cycle:	Make sure that the compressor is plugged in and there is power at the outlet
	Make sure that the airline is connected to the compressor and the Model 1908-12
	Make sure the air compressor is turned on
	Check the air regulator to see that it is set between 85 and 90 PSI - If not, adjust it to this setting - Turning the knob counterclockwise lowers the pressure and clockwise raises the pressure
	Check to see that dwell setting knob is between "A" and "B"
	Check to see if that conveyor chain tension is not overly tight
	Check to make certain that a tray carrier is not installed improperly where the pins on the conveyor chains are not engaged in the holes of the tray carrier
	Check to see that film has not wound around the cutter mechanism to the point that it is bound up on the tray carriers



Make sure the safety switches are not tripped

Lower latch spring is not broken

SYMPTOM

CORRECTIVE ACTION

Poor seal quality

Verify that the platen is heated by placing your hand near the platen and try to detect if there is heat radiating out from it-DO NOT TOUCH THE PLATEN

Check to see if the platen is dirty

Check rubber gasket on tray carriers for damaged or missing pieces

Check to see that the film is centered on the tray

Check to see that the heat seal dwell is set properly

Make sure that the tray flanges are not contaminated with product

Platen does not heat up

Verify that the power cord is plugged into outlet

Verify that there is power at the outlet

Film does not cut

Check to see if there is film wrapped around the cutter blade-You must remove the cutter guard to do this and if there is film wrapped around it the film must be cut away and pulled off- THE CUTTER BLADE IS SHARP, DO NOT TOUCH-REMOVE AIR AND ELECTRICAL POWER PRIOR TO REMOVING GUARD

Check to see if cutter blade is missing



Oliver Packaging & Equipment Company
3236 WISON DR NW WALKER MI. 49534

(800) 253-3893
www.oliverquality.com

Check to see if cutter blade is dull

Check to see if the cutter blade is dirty

Film is not centered on tray

**Adjust the plastic guides on the film holder
so that the film is centered over the trays**



PARTS LIST

<u>PART NUMBER</u>	<u>PART DESCRIPTION</u>
1908-0033	PLATEN SNIOR MEAL HEATER 275F
5730-1574	HEATER-CARTRIDGE 1/2"DIA X 8"L
5148-5531	VALVE-4WAY, PANEL MTD SPL UPER
5148-6511	TIMER PNEUM. 1-3 SEC UPPER
5143-2002	SPRING-AIR ACTUATOR 1B5-500
5757-9733	THERMOSWITCH SURFACE MOUNT
7024-4104	SPRING-TENS.750OD X2 1/2"T302
5114-9597	FILTER-COALESING W/AUTO DRAIN
5108-6603	CYLINDER-AIR 2"B X 6"-STROKE
5148-5527	4-WAY VALVE PILOT OPERATED
5130-7070	SPEED CONTROL MUFFLER 1/8 PIPE
5115-8451	SOCKET-BANJO 1/4 PORT SIZE
5141-9950	SENSOR PNEUMATIC-THRESHOLDS
5148-5815	VALVE-FLOW CONTROL 1/4 F NPT
1908-0034-1	LATCH UPPER STOP (17FT)
4605-1000-0034	TORSION SPRING RIGHTHAND LWR
1908-0035-1	LATCH LOWER STOP (17FT)
4605-1000-0036	TORSION SPRING LEFTHAND UPR
5144-3001	MEMORY MODULE PLMA12
5148-5533	5-PORTS MECHANICAL AIR VALVE
5148-6506	TIMER PNEUM. 1-3 SEC LOWER
1908-0199	MAIN-CHAIN (532 PITCHES)
1908-0139	STRIP-WEAR DRIVE



ELECTRICAL

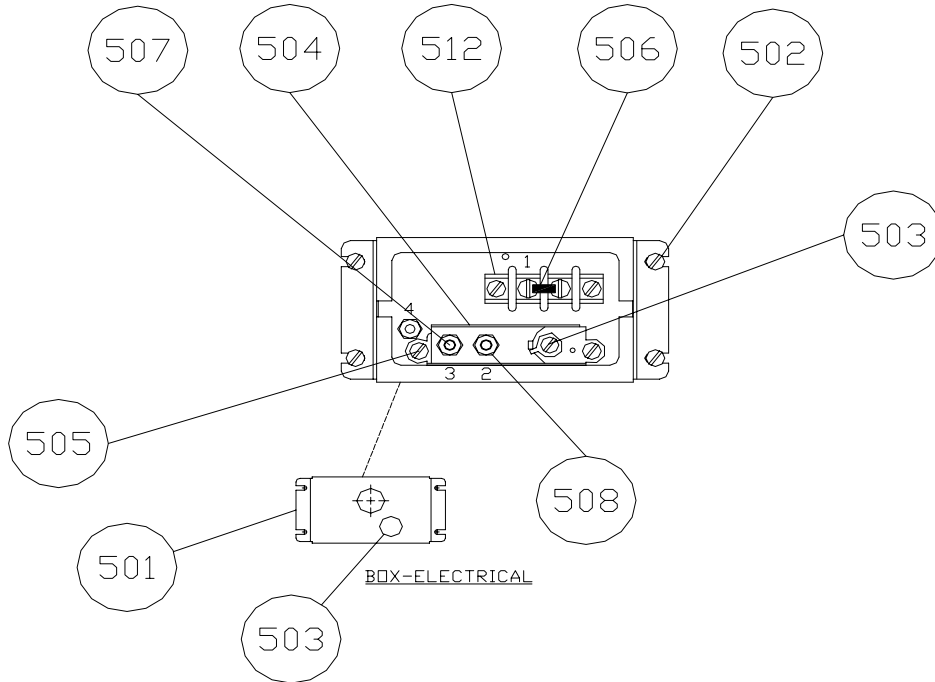

**ELECTRICAL DIAGRAM
 1/60/115**

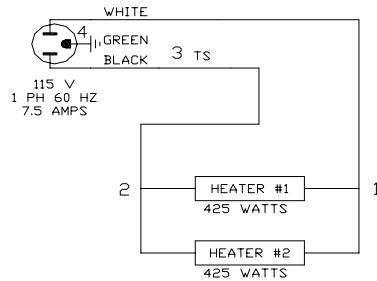

501	1508-0013-1	BOX-ELECTRICAL	1
502	5843-5210	SCREW-ROUND HD 6-32 X 1/4 STST	4
503	5765-4732	PLUG SNAP BUTTON 1/2" HOLE N/P	1
504	5757-9733	THERMONSWITCH-SURFACE MOUNT	1
505	5843-5211	SCREW-ROUND HD 6-32 X 3/8 STST	2
506	5770-7461	JUMPER-TERMINAL BLOCK	1
507	5843-5215	SCREW-MACH 6-32X 5/8" RDHD STST	2
508	5851-9353	WASHER-#6 STST MED SPRING LOCK	2
511	5766-7750	NUT-LOCK APPLETON#BL-50	1

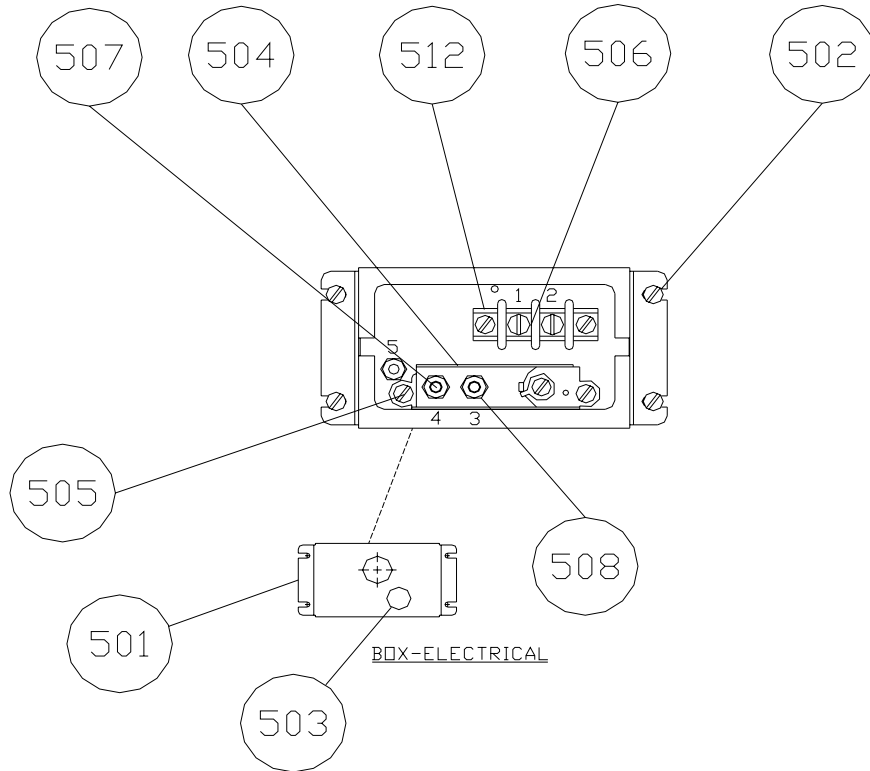

ELECTRICAL DIAGRAM
1/60/240

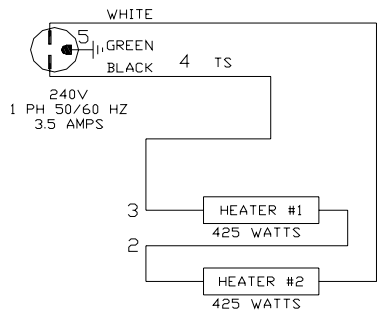

501	1508-0013-1	BOX-ELECTRICAL	1
502	5843-5210	SCREW-ROUND HD 6-32 X 1/4 STST	4
503	5765-4732	PLUG SNAP BUTTON 1/2" HOLE N/P	1
504	5757-9733	THERMONSWITCH-SURFACE MOUNT	1
505	5843-5211	SCREW-ROUND HD 6-32 X 3/8 STST	2
507	5843-5215	SCREW-MACH 6-32X 5/8" RDHD STST	2
508	5851-9353	WASHER-#6 STST MED SPRING LOCK	2
511	5766-7750	NUT-LOCK APPLETON#BL-50	1



WARRANTY

PARTS

Oliver Packaging & Equipment Company warrants that if any part of the equipment (other than a part not manufactured by Oliver Packaging & Equipment) proves to be defective (as defined below) within one year after shipment, and if Buyer returns the defective part to Oliver Packaging & Equipment within one year, Freight Prepaid to Oliver Packaging & Equipment's plant in Grand Rapids, MI, then Oliver Packaging & Equipment, shall, at Oliver Packaging & Equipment's option, either repair or replace the defective part, at Oliver Packaging & Equipment's expense.

LABOR

Oliver Packaging & Equipment further warrants that equipment properly installed in accordance with our special instructions, which proves to be defective in material or workmanship under normal use within one (1) year from installation or one (1) year and three (3) months from actual shipment date, whichever date comes first, will be repaired by Oliver Packaging & Equipment or an Oliver Packaging & Equipment Authorized Service Dealer, in accordance with Oliver Packaging & Equipment's published Service Schedule.

For purposes of this warranty, a defective part or defective equipment is a part or equipment which is found by Oliver Packaging & Equipment to have been defective in materials workmanship, if the defect materially impairs the value of the equipment to Buyer. Oliver Packaging & Equipment has no obligation as to parts or components not manufactured by Oliver Packaging & Equipment, but Oliver Packaging & Equipment assigns to Buyer any warranties made to Oliver Packaging & Equipment by the manufacturer thereof.

This warranty **does not** apply to:

1. Damage caused by shipping or accident.
2. Damage resulting from improper installation or alteration.
3. Equipment misused, abused, altered, not maintained on a regular basis, operated carelessly, or used in abnormal conditions.
4. Equipment used in conjunction with products of other manufacturers unless such use is approved by Oliver Packaging & Equipment in writing.
5. Periodic maintenance of equipment, including but not limited to lubrication, replacement of wear items, and other adjustments required due to installation, set up, or normal wear.
6. Losses or damage resulting from malfunction.

The foregoing warranty is in lieu of all other warranties expressed or implied AND OLIVER PACKAGING & EQUIPMENT MAKES NO WARRANTY OF MERCHANTABILITY OR FITNESS FOR PURPOSE REGARDING THE EQUIPMENT COVERED BY THIS WARRANTY. Oliver Packaging & Equipment neither assumes nor authorizes any person to assume for it any other obligations or liability in connection with said equipment. OLIVER PACKAGING & EQUIPMENT SHALL NOT BE LIABLE FOR LOSS OF TIME, INCONVENIENCE, COMMERCIAL LOSS, INCIDENTAL OR CONSEQUENTIAL DAMAGES.



Oliver Packaging & Equipment Company
3236 WISON DR NW WALKER MI. 49534

(800) 253-3893
www.oliverquality.com

WARRANTY PROCEDURE

1. If a problem should occur, either the dealer or the end user must contact the Customer Service Department and explain the problem.
2. The Customer Service Manager will determine if the warranty will apply to this particular problem.
3. If the Customer Service Manager approves, a Work Authorization Number will be generated, and the appropriate service agency will perform the service.
4. The service dealer will then complete an invoice and send it to the Customer Service Department at Oliver Packaging & Equipment Company.
5. The Customer Service Manager of Oliver Packaging & Equipment Company will review the invoice and returned parts, if applicable, and approve for payment.



Oliver Packaging & Equipment Company
3236 WISON DR NW WALKER MI. 49534

(800) 253-3893
www.oliverquality.com

RETURNED PARTS POLICY

This policy applies to all parts returned to the factory whether for warranted credit, replacement, repair or re-stocking.

Oliver Packaging & Equipment Company requires that the customer obtain a Return Material Authorization (RMA) number before returning any part. This number should appear on the shipping label and inside the shipping carton as well. All parts are to be returned prepaid. Following this procedure will insure prompt handling of all returned parts.

To obtain an RMA number contact the Repair Parts Department toll free at (800) 253-3893.

Parts returned for re-stocking are subject to a **RE-STOCKING CHARGE**.

Thank you for your cooperation,

Repair Parts Manager
Oliver Packaging & Equipment Company