



Walker, Michigan, U.S.A. 49534-7564

USER'S OPERATING AND INSTRUCTION MANUAL

MODEL 2005

VARIABLE SLICE THICKNESS
BREAD SLICER





2005 (UL) VARIABLE THICKNESS BREAD SLICER

INDEX

<u>Section Description</u>	<u>Document No.</u>	<u>Page No.</u>
SAFETY INSTRUCTIONS -----	2005S20021 -----	1-1
DESCRIPTION/SPECIFICATIONS -----	2005S20022 -----	2-1
Description -----		2-1
Physical Specifications -----		2-1
OPERATING INSTRUCTIONS -----	2005S20023 -----	3-1
MAINTENANCE -----	2005S20024 -----	4-1
Cleaning -----		4-1
Lubrication -----		4-1
Changing a Blade -----		4-1
TROUBLESHOOTING / SET-UP -----	2005S20025 -----	5-1
Nothing Happens When the Machine is Turned On -----		5-1
Slice Thicknesses Are Not Equal -----		5-1
Slices Are Being Pulled Up Or Pushed Down Between the Tables -----		5-1
The Blade is Crushing the Bread -----		5-2
Slicing Starts Before the Bread is Beneath the Blade -----		5-2
The Knife Vibrates Excessively -----		5-2
The Machine Makes a Loud Thumping Sound -----		5-2
Manual Diagnostic and Set-Up Mode -----		5-3
RECOMMENDED SPARE PARTS -----	2005S20026 -----	6-1
REPLACEMENT PARTS SECTION		
MAIN FRAME -----	2005S20027 -----	7-1
Drawing -----		7-1
Parts List -----		7-2
BLADE & CLUTCH DRIVE -----	2005S20028 -----	8-1
Drawing -----		8-1
Parts List -----		8-2
CUTOFF ARM -----	2005S20029 -----	9-1
Drawing -----		9-1
Parts List -----		9-2

Continued



2005 (UL) VARIABLE THICKNESS BREAD SLICER

INDEX (Continued)

REPLACEMENT PARTS SECTION (Continued)

<u>Section Description</u>	<u>Document No.</u>	<u>Page No.</u>
PUSHER WITH STEPPER -----	2005S20030 -----	10-1
Drawing -----		10-1
Parts List -----		10-2
TABLES & COVERS -----	2005S20031 -----	11-1
Drawing -----		11-1
Parts List -----		11-2
CLUTCH -----	2005S20032 -----	12-1
Drawing -----		12-1
Parts List -----		12-2
ELECTRICAL SUB-PANEL -----	2005S20033 -----	13-1
Drawing -----		13-1
Parts List -----		13-2
ELECTRICS 1-60-115 VAC -----	2005S20034 -----	14-1
Parts List -----		14-1
WIRING DIAGRAMS -----	2005S20035 -----	15-1
WARRANTY -----	GEN 040225	
WARRANTY PROCEDURE -----	GEN 040226	
RETURNED PARTS POLICY -----	GEN 040227	



2005 VARIABLE THICKNESS BREAD SLICER

SAFETY INSTRUCTIONS

Various safety devices and methods of guarding have been provided on this machine. It is essential; however, that machine operators and maintenance personnel observe the following safety precautions. Improper installation or operation of this equipment may cause injury to personnel or damage to equipment.

1. Read this manual before attempting to set-up and service your machine. Never allow an untrained person to service this machine.
2. Connect the machine to a properly grounded electrical supply that matches the requirements shown on the electrical specification plate and follow specifications of local electrical codes.
3. Disconnect and lock-out the machine from the power supply before cleaning or servicing.
4. Check and secure all guards before starting the machine.
5. Observe all caution and warning labels affixed to the machine.
6. Use only proper replacement parts.
7. Do not wear loose fitting clothing or unrestrained long hair. Shirt tails should be tucked in.
8. Wear proper personal safety equipment.
9. Keep Hands away from the moving parts of this machine while it is in operation.
10. In addition to these general safety instructions, also follow the more specific safety instructions given for the different areas of the machine in the operating instructions.

WARNING

DO NOT USE FOR OTHER THAN ORIGINALLY INTENDED PURPOSE



2005 VARIABLE THICKNESS BREAD SLICER

DESCRIPTION/SPECIFICATION

Description

The Oliver Model 2005 is a variable slice thickness bread slicer, which utilizes a new and innovative way to slice bread. The bread is moved past a circular blade, which is mounted to a moving arm, cutting each slice individually to whatever thickness is selected. The slicer is designed for on-demand slicing allowing your customers to choose a slice thickness to satisfy their needs. The 2005 slicer also has a multi-lingual digital display prompting the user with normal operating information.

The slicer employs a disc brake on the blade drive motor, which mechanically engages to stop the blade whenever the blade is exposed due to a door being opened, or after the slicing cycle is finished.

NOTE

THIS MACHINE IS NOT INTENDED TO BE USED TO SLICE WARM, STICKY, NUT AND/OR FRUIT BREADS.

Physical Specifications

Product Capacities:

The slicer will process loaves up to 9 inches by 4-1/4 inches by 15 inches long.

Overall Machine size:

- Width = 36 inches
- Height = 28-1/2 inches, Requiring a minimum of 38



2005 VARIABLE THICKNESS BREAD SLICER

OVERALL MACHINE DIMENSIONS

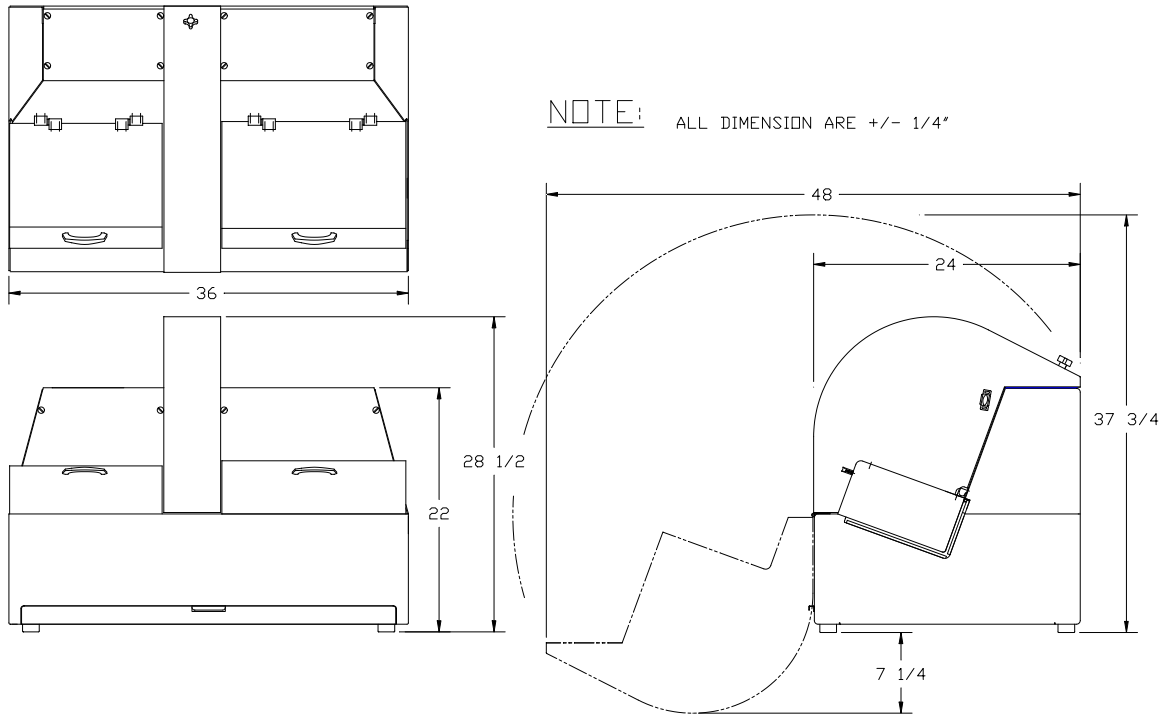



2005 VARIABLE THICKNESS BREAD SLICER

OPERATING INSTRUCTIONS

Start-up:

Close both doors. Turn the machine on. The pusher will move back to home if the machine has been turned off while the pusher is out of the home (farthest left) position. The display will display the Oliver logo and language selections.

Standard Operation:

- Hold open the left door with left your hand.
- Place a loaf of bread on the infeed (left hand) table.
- Slide the loaf onto the pins of the pusher so that pins penetrate the loaf, until it is firmly against the front of the pusher block.
- Close door(s).

NOTE

THE MACHINE WILL NOT OPERATE IF EITHER DOOR IS OPEN.

- Make a language selection on the touch screen.
- Select the appropriate slice thickness setting. The machine will begin slicing.
- Wait for the bread to be sliced. When the machine stops, the bread will be in the right hand compartment.
- Open the right hand door and remove the loaf.
- Close the door, allowing the pusher to return to the home position.
- Once the pusher has returned and stopped you may repeat the above procedure to slice additional loaves.

Stopping:

If a slice gets jammed, press **STOP**, to stop slicing, turn the power off, disconnect and lockout the slicer before trying to clear the machine.

CAUTION

**DO NOT OPEN THE DOORS WHILE THE SLICER IS OPERATING.
DOING SO WILL CAUSE SLICING TO STOP.**



2005 VARIABLE THICKNESS BREAD SLICER

MAINTENANCE

WARNING

DISCONNECT AND LOCK OUT THE MACHINE FROM THE POWER SUPPLY BEFORE CLEANING OR SERVICING.

REMEMBER TO USE CARE AND WEAR CUT RESISTANT GLOVES WHENEVER YOU ARE WORKING WITH OR NEAR THE BLADE.

Cleaning: (daily)

Use a mild detergent solution applied with a cloth or spray cleaner on all exterior and interior surfaces as necessary. Use brushes provided with machine to clean openings or recesses in and around in-feed and out-feed tables. Remove and empty contents of the crumb tray daily. Periodically (weekly) remove the blade and clean the blade compartment using the same methods as above.

IMPORTANT

The blade must be cleaned each day, you **Do Not** need to remove the blade to clean it. Use a mild detergent solution or spray cleaner. For harder deposits use a non scratch cleaning pad similar to Scotch-brite (tm).

Lubrication:

All motors and bearings are pre-lubricated and sealed: lubrication in not required. **Do Not** attempt to oil or grease the motor.

Removing the blade:

WARNING

DISCONNECT AND LOCK OUT THE MACHINE FROM THE POWER SUPPLY BEFORE CLEANING OR SERVICING.

REMEMBER TO USE CARE AND WEAR CUT RESISTANT GLOVES WHENEVER YOU ARE WORKING WITH OR NEAR THE BLADE.

- Tilt the blade guard forward after removing the knob, (located at the top of the guard), which secures it in place. Gently rest it all the way open.
- Remove the blade mounting screw using a 1/2 inch wrench.
- Remove the lock-washer, special washer, 2 inch diameter collar, and the circular knife.
- The blade can be replaced by reversing the above procedure.
- When reinstalling the blade, make sure the beveled side faces the outfeed (FLAT SIDE TOWARD INFEEED). Make sure the blade is centered and supported on the arbor.



2005 VARIABLE THICKNESS BREAD SLICER

TROUBLE SHOOTING/ SET-UP GUIDE

WARNING

DISCONNECT AND LOCK OUT THE MACHINE FROM THE POWER SUPPLY BEFORE CLEANING OR SERVICING.

WARNING

REMEMBER TO USE CARE AND WEAR CUT RESISTANT GLOVES WHENEVER YOU ARE WORKING WITH OR NEAR THE BLADE.

WARNING

TROUBLESHOOTING OF ELECTRICAL EQUIPMENT MUST BE PERFORMED BY QUALIFIED PERSONNEL ONLY.

Nothing Happens When The Machine Is Turned On.

- Check to see if the machine is plugged in.
- Check to see if there is power at the outlet.
- Check to see if any of the circuit breakers have tripped. They are located near the lower, right hand, rear corner of the machine.

Slice Thicknesses Are Not Equal.

- The bread is not being pressed completely onto the pins of the pusher block, therefore allowing the loaf to shift on the pins between cuts.
- Bread is getting caught in the gap between the infeed and outfeed tables preventing free movement of the product. Re-adjust the outfeed table for minimum gap, while still allowing free movement of the slicer blade. Do **NOT** adjust the infeed table.
- The slicer blade is loose. Check the blade mounting screw and tighten if necessary.

Slices Are Being Pulled Up Or Pushed Down Through The Gap Between The Tables.

- A build-up on the blade from slicing warm bread or sticky fruit breads can cause this type of product damage or malfunction.
- The gap between the tables is too large. Re-adjust the outfeed table so that the gap between the infeed and outfeed tables is minimized while still allowing a comfortable clearance for the spinning knife.
- The arms of the hold-down could be bent to far away from the blade so that they cannot maintain control over the slices or crusts and they are pulled between the blade and hold-down.



2005 VARIABLE THICKNESS BREAD SLICER

The Blade Is Crushing The Bread.

- The bread may be too warm for slicing.
- A build-up on the blade from slicing warm bread or sticky fruit breads can cause this type of product damage or malfunction.
- The slicer drive motor may not be running, (the slicer knife will not be rotating). The motor is protected by a circuit breaker, located on the back of the machine, which may need to be reset.
- The Knife has become extremely dull and needs to be replaced.

Slicing Begins Too Soon, The Knife Takes Several Strokes Before The Product Is Beneath The Knife.

- The reflector inside of the Knife Cover is dirty.
- The



2005 VARIABLE THICKNESS BREAD SLICER

Manual Diagnostic and Set-Up Mode:

The machine may be put into Manual Diagnostic Mode to check several functions of the machine. To enter this mode, simply do the following:

- Wait for the initial screen to come up (pusher must be in the home position, and may take up to a minute) or cycle the power switch to bring up the initial screen.
- Press on the *Varislice* logo on the touch screen for about 20 seconds until the screen changes.
- There are several rectangular buttons on the touch screen display to activate the different actuators and colored (red/green) circle indicators to verify the switch function on the machine as follows:



REVISED 10-23-13



2005 VARIABLE THICKNESS BREAD SLICER

1. FWD and REV buttons move the pusher back and forth. (The covers must be closed to allow movement).

Moving the pusher can verify the smoothness of the pusher travel and can be used to test the switches on each end of the travel by observing the



2005 VARIABLE THICKNESS BREAD SLICER

RECOMMENDED SPARE PARTS

<u>PART NUMBER</u>	<u>PART DESCRIPTION</u>	<u>NO. REQ'D.</u>
2005-25018K	Cleaning Kit	1
2003-0006	Plate-Pusher W/Pins	1
2005-0115	Eye-Photo W/Harness	1
5757-7540	Switch-Reed W/ connectors	6
5250-0386	Bearing-Ball 1/2 X 1-1/8	1
5250-0387	Bearing-Ball 5/8 X 1-3/8	8
5251-3420	Bearing-Ball 4B Flange	2
5254-3190	Bearing-Bronze Flange	1
5254-3507	Bearing-Thrust	1
5601-1033	Belt-V 3L230	2
5601-3341	Belt-Timing 300L075	1
5601-3420	Belt-Timing 510L050	1
5601-3450	Belt-Timing 165L050	1
5711-9011	Reflector-3" Round	1
5840-1020	Ring-Retaining N5000-112	2
5840-1026	Ring-Retaining N5000-137	2
5840-1125	Ring-Retaining #5100-50	1
5840-1128	Ring-Retaining #5100-62	5
6309-6014	Resistor-Control (Plug-In)	1
5749-8027	Relay-Power	1
5757-4125	Breaker-Circuit 2.5A	1
5757-4279	Breaker-Circuit 5.0A	1
5757-4358	Breaker-Circuit 15.0A	1
4560-2508-1106	Knob-Screw	1

OPTIONAL SPARE PARTS

2001-0019	Shaft-Clutch Drive	1
5746-5672	Power Supply AC/DC	1
6309-6000	Control-DC Drive	1
6300-0017	Motor-Stepping	1
5604-5257	Clutch-CB-5	1
2005-0118-004	PLC (pre-programmed)	1
2005-0119-005	Touch Screen (pre-programmed)	1
6301-5611	Motor-Brake 3/4 HP (115/230 VAC)	1
6310-0008	Gearmotor (1/8 HP 90 VDC)	1
7107-7056	Knife-Scalloped Circular	1



2005 VARIABLE THICKNESS BREAD SLICER

MAIN FRAME ASSEMBLY

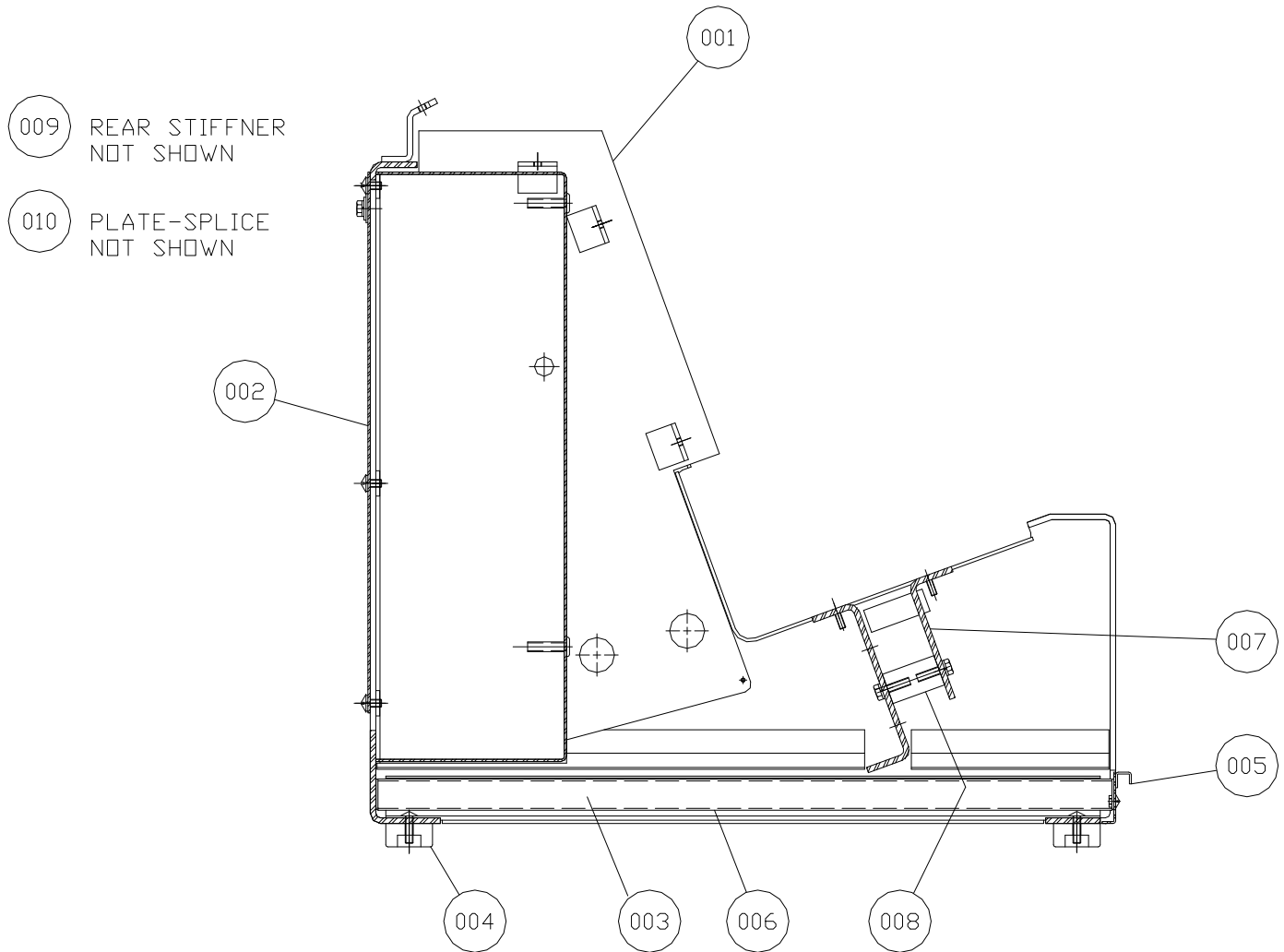



2005 VARIABLE THICKNESS BREAD SLICER

MAIN FRAME PARTS LIST

<u>ITEM NO.</u>	<u>PART DESCRIPTION</u>	<u>PART NUMBER</u>
001	Main Frame	2005-0054
002	Cover-Electrical	2003-0021
003	Track-Crumb Tray	2003-0038
004	Bumper-Rubber	5902-0021
005	Plate-Face	2003-0003
006	Tray-Crumb	2003-0037
007	Angle-Table Support	2003-0011-1
008	Spacer-Angle	2003-0034
*009	Stiffener	2003-0054-1
*010	Plate-splice	2005-0058

***Not shown on drawing**

Rev. 1/25/05



2005 VARIABLE THICKNESS BREAD SLICER

BLADE & CLUTCH DRIVE ASSEMBLY

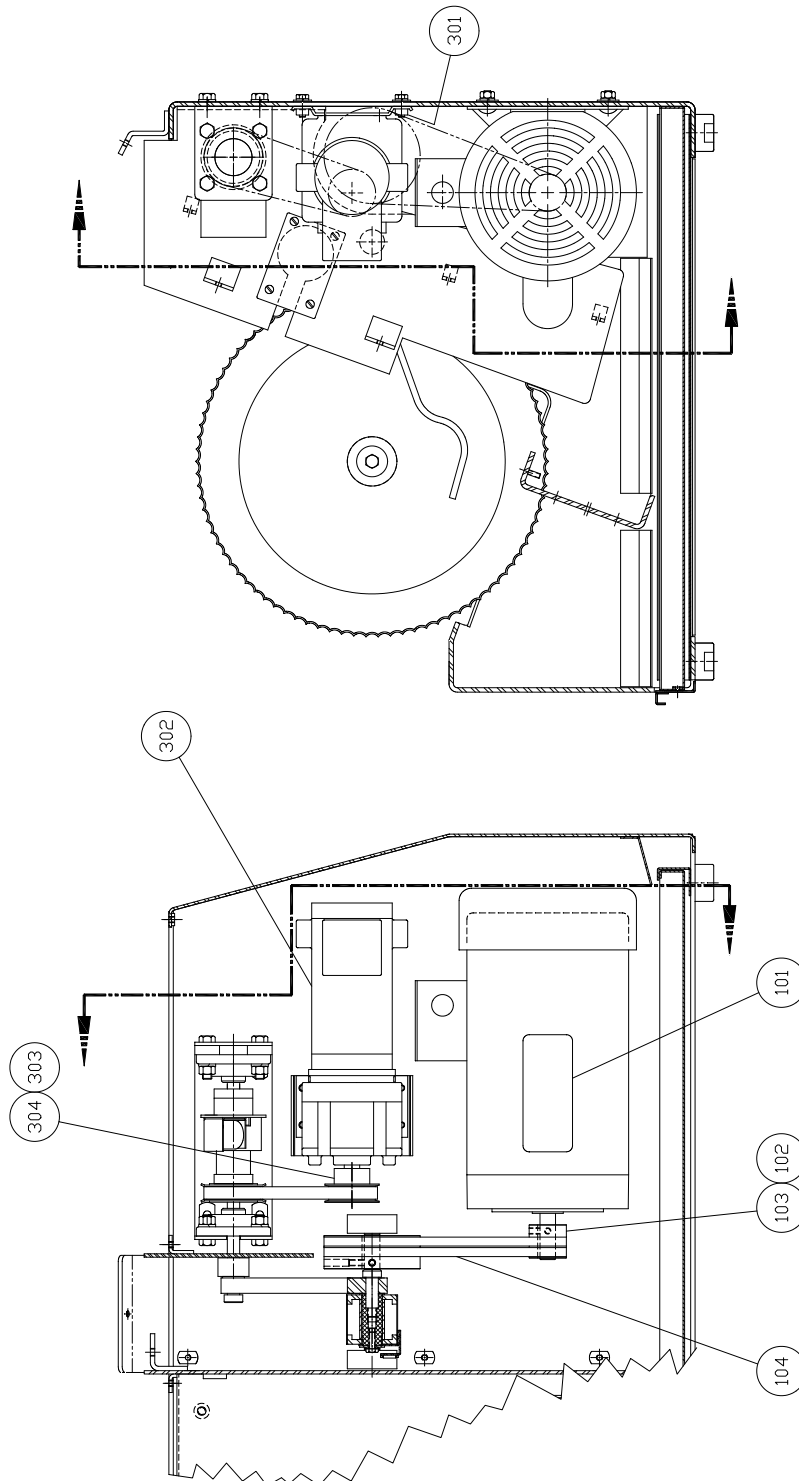



2005 VARIABLE THICKNESS BREAD SLICER

BLADE & CLUTCH DRIVE PARTS LIST

<u>ITEM NO.</u>	<u>PART DESCRIPTION</u>	<u>PART NUMBER</u>
101	Motor-Brake 3/4 HP	6301-5611
103	Sheave 3L, 2-Grooves 1.5 OD	2003-0070
104	Belt-V 3L230	5601-1033
301	Nutbar	2001-0015
302	Gearmotor 1/8 HP DC (115 VAC)	6310-0008
304	Pulley-Timing Belt	4495-2816-2001



2005 VARIABLE THICKNESS BREAD SLICER

CUTOFF ARM ASSEMBLY

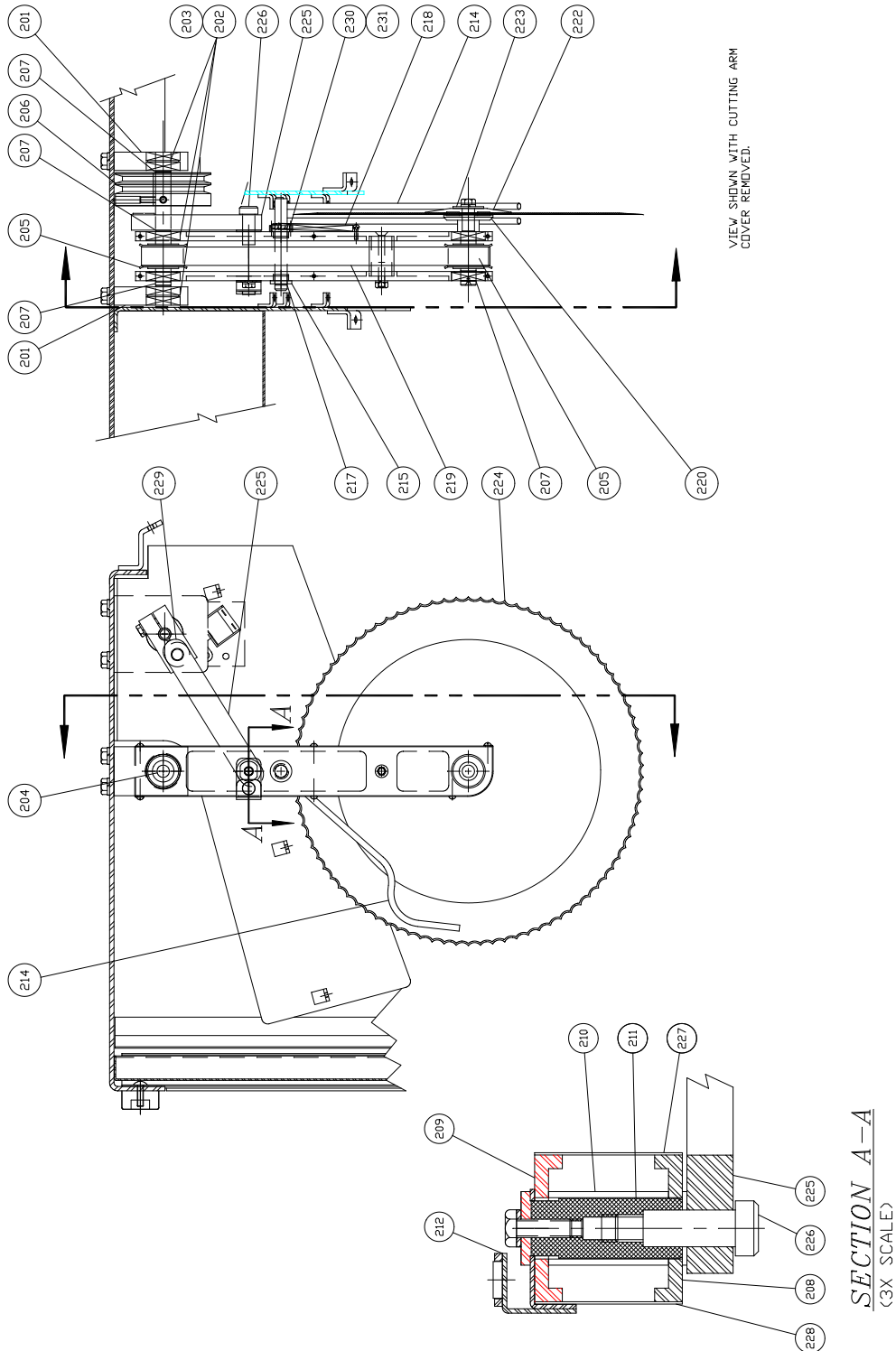



2005 VARIABLE THICKNESS BREAD SLICER

CUTOFF ARM PARTS LIST

<u>ITEM NO.</u>	<u>PART DESCRIPTION</u>	<u>PART NUMBER</u>
201	Block-Pivot Outside	2001-0041
202	Bearing-Ball	5250-0387
203	Ring-Retaining #N5000-137	5840-1026
204	Shaft-Drive	2001-0047-1
205	Pulley-Timing Belt	2003-0044
206	Sheave-3L, 2-Grooves 3.882 OD	2003-0071
207	Ring-Retaining #5100-62	5840-1128
208	Side-RH Arm	2003-0046-1
209	Side-LH Arm	2003-0047
210	Spacer-Aluminum Tube	2003-0050
211	Trunnion	2003-0052
212	Flag	2005-0036
214	Holddown	2003-0064
215	Bearing-Bronze Flange	5254-3190
217	Ring-Retaining #5100-50	5840-1125
218	Spring-Extension	7021-4005
219	Belt-Timing 300L075	5601-3341
220	Spindle-Blade	2001-0072-101
222	Disk/Collar	2001-0073-001
223	Washer-Special	2001-0074
224	Knife-Scalloped	7107-7056
225	Rod-Connecting	2003-0027
226	Screw-Shoulder 1/2 X 1-1/4	5842-8545
227	Cover-Top	2003-0048
228	Cover-Bottom	2003-0049
229	Bearing-Bronze Thrust	5254-3507
230	Bushing-Stop	2003-0065
231	Pin-Coiled	5835-7625



2005 VARIABLE THICKNESS BREAD SLICER

PUSHER WITH STEPPER ASSEMBLY

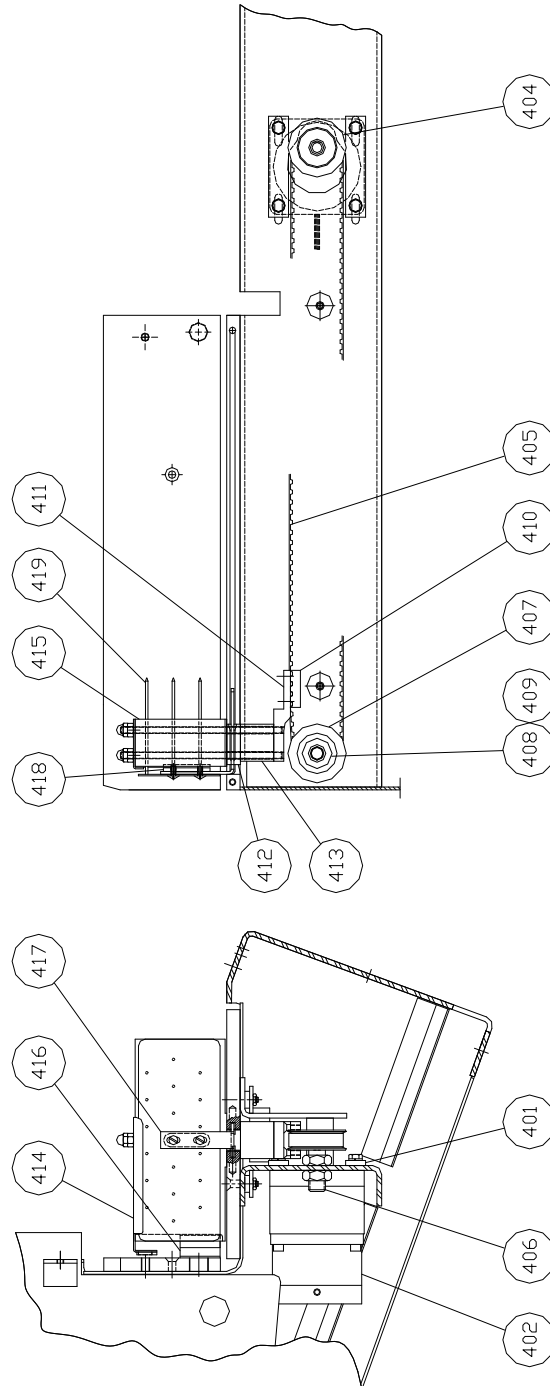

Rev. 10-8-03



2005 VARIABLE THICKNESS BREAD SLICER

PUSHER WITH STEPPER PARTS LIST

<u>ITEM NO.</u>	<u>PART DESCRIPTION</u>	<u>PART NUMBER</u>
401	Bar-Motor	2005-0049
402	Motor-Stepper	6300-0017
404	Pulley-Timing Belt	2005-0039
405	Belt-Timing # 510L050	5601-3420
406	Spindle-Idler	2001-0051
407	Pulley-Idler Timing	2001-0050
408	Bearing-Ball	5250-0386
409	Ring-Retaining # N5000-112	5840-1020
410	Clamp-Belt	2001-0034
411	Hitch-Pusher	2003-0007
412	Block-Center Wear	2001-0046
413	Pad-Bottom Wear	2003-0010
414	Bracket-Magnet	2005-0047-1
415	Block-Pusher	2003-0005
416	Wiper Blade Assembly	2003-0009
417	Bracket-Pusher	2001-0035
418	Nutbar-Pusher	2001-0089
419	Plate-Pusher W/Pins	2003-0006

Rev. 10-8-03



2005 VARIABLE THICKNESS BREAD SLICER

TABLE & COVER ASSEMBLY

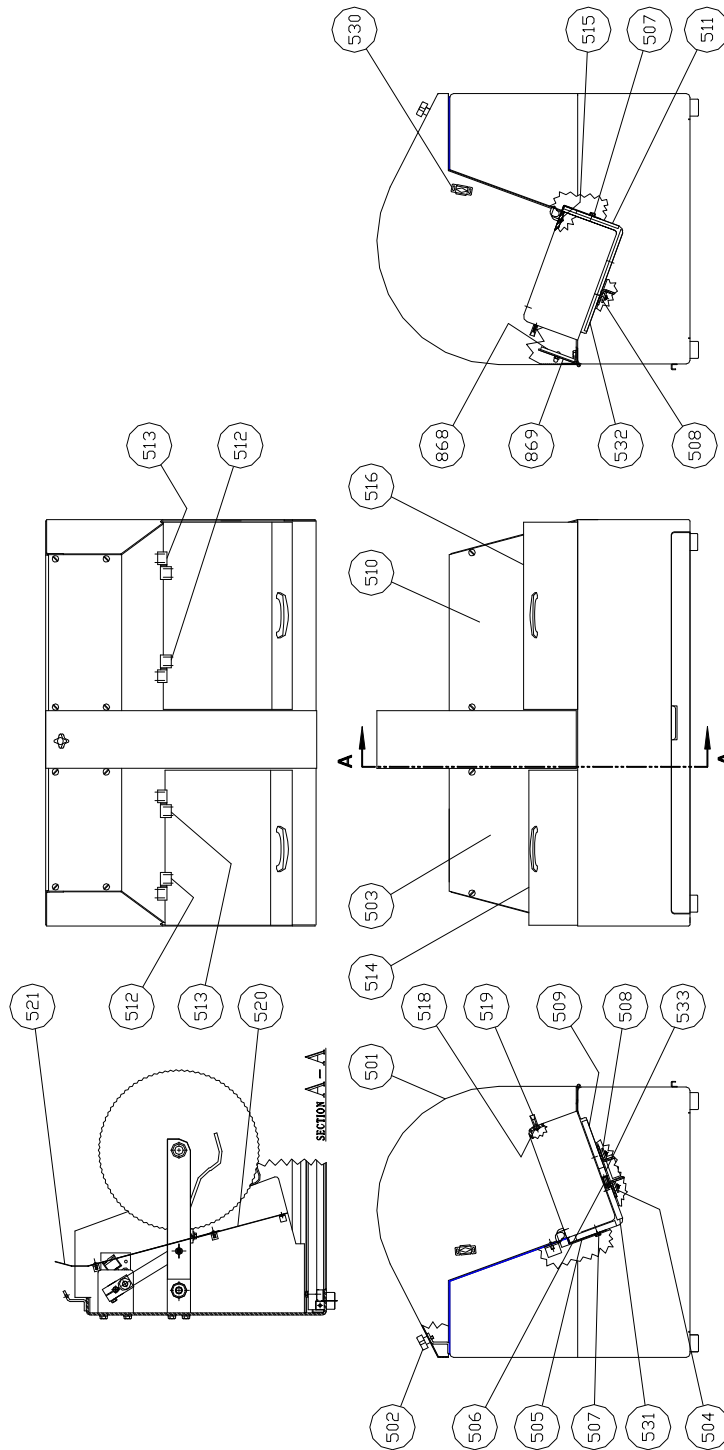



2005 VARIABLE THICKNESS BREAD SLICER

TABLE & COVER PARTS LIST

<u>ITEM NO.</u>	<u>PART DESCRIPTION</u>	<u>PART NUMBER</u>
501	Guard-Blade	2005-0014-001
502	Knob-Screw	4560-2508-1106
503	Panel-Infeed	2005-0043-003
504	Nutbar-Infeed	2001-0102-001
505	Table-Rear Adj. Infeed	2005-0050-1
506	Pin 1/4 Diameter X 3/4	4475-0516-075
507	Nut-Cage 1/4-20	5832-0425
508	Nutbar-Outfeed	2001-0103-001
509	Table-Front Adj. Infeed	2005-0048-1
510	Panel-Outfeed	2005-0044-001
511	Table-Rear Adj. Outfeed	2005-0052
512	Hinge-Type "A"	5908-9845
513	Hinge-Type "B"	5908-9846
514	Cover-Infeed	2005-0041
515	Plate-Hinge Backer	2005-0046
516	Cover-Outfeed	2005-0040
518	Strip-Handle Backer	2000-0087
519	Handle-Pull	5908-5100
520	Chute-Lower Crumb	2003-0030
521	Chute-Upper Crumb	2005-0012
530	Catch-Magnetic W/Strike	5805-2503
531	Table-Bottom Adj. Infeed	2005-0051-2
532	Table-Bottom Adj. Outfeed	2005-0053
533	Spacer-Table	2005-0061
868	Reflector-3" Round	5711-9011
869	Bracket-Reflector	2005-0019

Rev. 1-20-20



2005 VARIABLE THICKNESS BREAD SLICER

CLUTCH ASSEMBLY

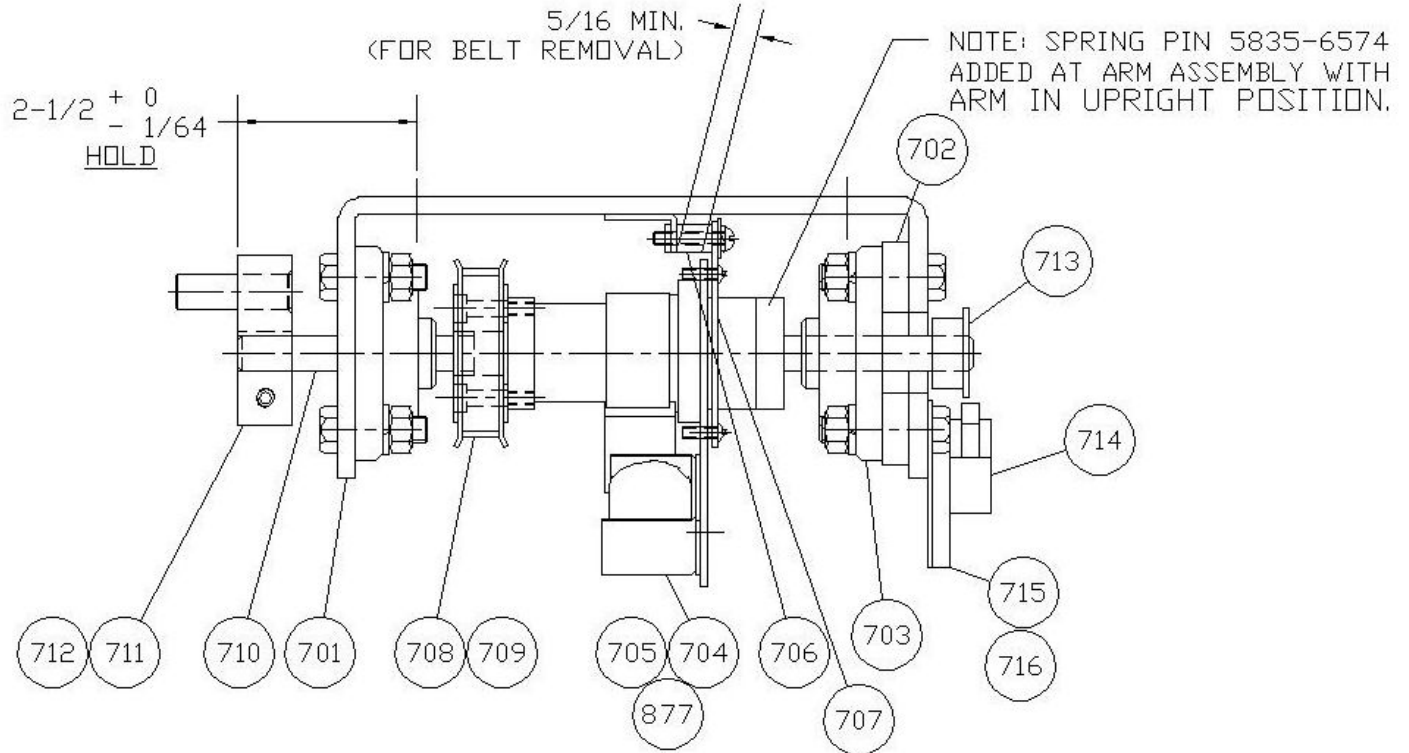

Rev. 12/13/12

CLUTCH ASSEMBLY PARTS LIST

<u>ITEM NO.</u>	<u>PART DESCRIPTION</u>	<u>PART NUMBER</u>
701	Bracket-Clutch	2005-0124
702	Spacer	2001-0032
703	Bearing-Flange Ball	5251-3420
704	Clutch	5604-5257
705	Cover-Clutch	5604-5518
706	Spacer-Anchor	2001-0017
707	Plate-Anchor	2001-0033
708	Pulley-Timing Belt	2001-0001



2005 VARIABLE THICKNESS BREAD SLICER

709	Belt-Timing # 165L050	5601-3450
710	Shaft-Drive	2005-0123
711	Crank	2003-0028
712	Key	4384-0404-075
713	Cam, Arm Switch	2005-0120
714	Switch, Roller	5757-8002
715	Block, Limit Switch Spacer	1908-0408
716	Plate, Arm Switch	2005-0121

Rev. 12/13/12



2005 VARIABLE THICKNESS BREAD SLICER

ELECTRICAL SUB-PANEL ASSEMBLY

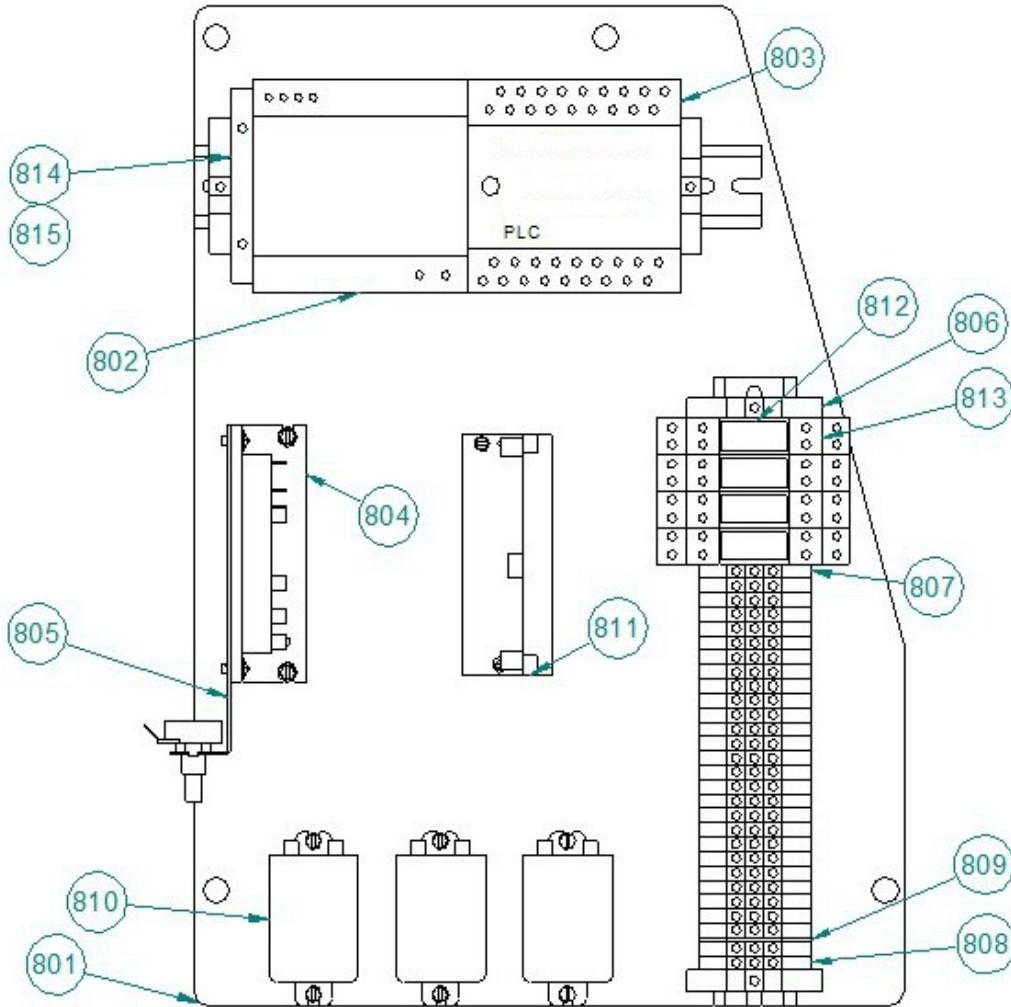



2005 VARIABLE THICKNESS BREAD SLICER

ELECTRICAL SUB-PANEL PARTS LIST

<u>ITEM NO.</u>	<u>PART DESCRIPTION</u>	<u>PART NUMBER</u>
801	Sub-panel	2005-0008-1
802	Power Supply-24VDC Class II	5746-5672
803	PLC-Control (Programmed)	2005-0118-004
804	Control- DC Drive w/wired Pot -----(Board only 6309-6000)	2005-0116
805	Bracket, Potentiometer Mnt.	2005-0117
806	Anchor Block- Terminal	5770-7475
807	Block- Terminal	5770-7472
808	Block-Ground Terminal Block	5770-7473
809	Barrier	5770-7474
810	Relay-Power	5749-8010
811	Driver, Stepper Motor	6309-8001
812	Relay, Control (Interlock)	5749-5674
813	Socket, for Relay	5770-2832
814	Fuse Holder	5726-1200
815	Fuse, 2 Amp Slow-Blow	5725-9272
820	Switch-Reed	5757-7540
821	Washer	8851-8466
822	Cord-Power 115V	2005-0102
823	Bushing-Strain Relief	5765-1079
824	Harness-Wire (Stepper)	2005-0100
825	Wire-Ground 6"	2005-0037
826	Harness-Wire 18" (Arm Sensor)	2005-0113
827	Harness-Wire (LT Door Switch)	2005-0112
828	Harness-Wire (RT Door Switch)	2005-0111
829	Eye-Photo	2005-0115
830	Harness-Wire (Drive Motor)	2005-0101
831	Harness-Wire (DC Motor)	2005-0029
832	Wire (Clutch)	2005-0107
833	Wire (Clutch)	2005-0108



2005 VARIABLE THICKNESS BREAD SLICER

ELECTRICAL SUB-PANEL PARTS LIST (continued)

834	Grommet (1/16" W/Groove)	5767-1208
835	Grommet (1/8" W/Groove)	5767-1206
836	Reflector-3" Round	5711-9011
837	Bracket-Reflector	2005-0019
838	Operator Interface (Programmed)	2005-0119-005
839	Cable- Operator Interface	5744-1003
840	Switch- Main Power Rocker	5757-3307
841	Duct-Wiring	5766-3301
842	Cover-Wiring Duct	5766-3325
843	Breaker-Circuit 2.5A	5757-4125
844	Breaker-Circuit 5.0A	5757-4279
845	Breaker-Circuit 15.0A	5757-4358
846	Resistor-DC Motor Control	6309-6014
847	Resistor- 2.2K Ohm	5750-2311

Rev. 1-20-20



2005 VARIABLE THICKNESS BREAD SLICER

WIRE DIAGRAM 1-60-115 PAGE 1 OF 3

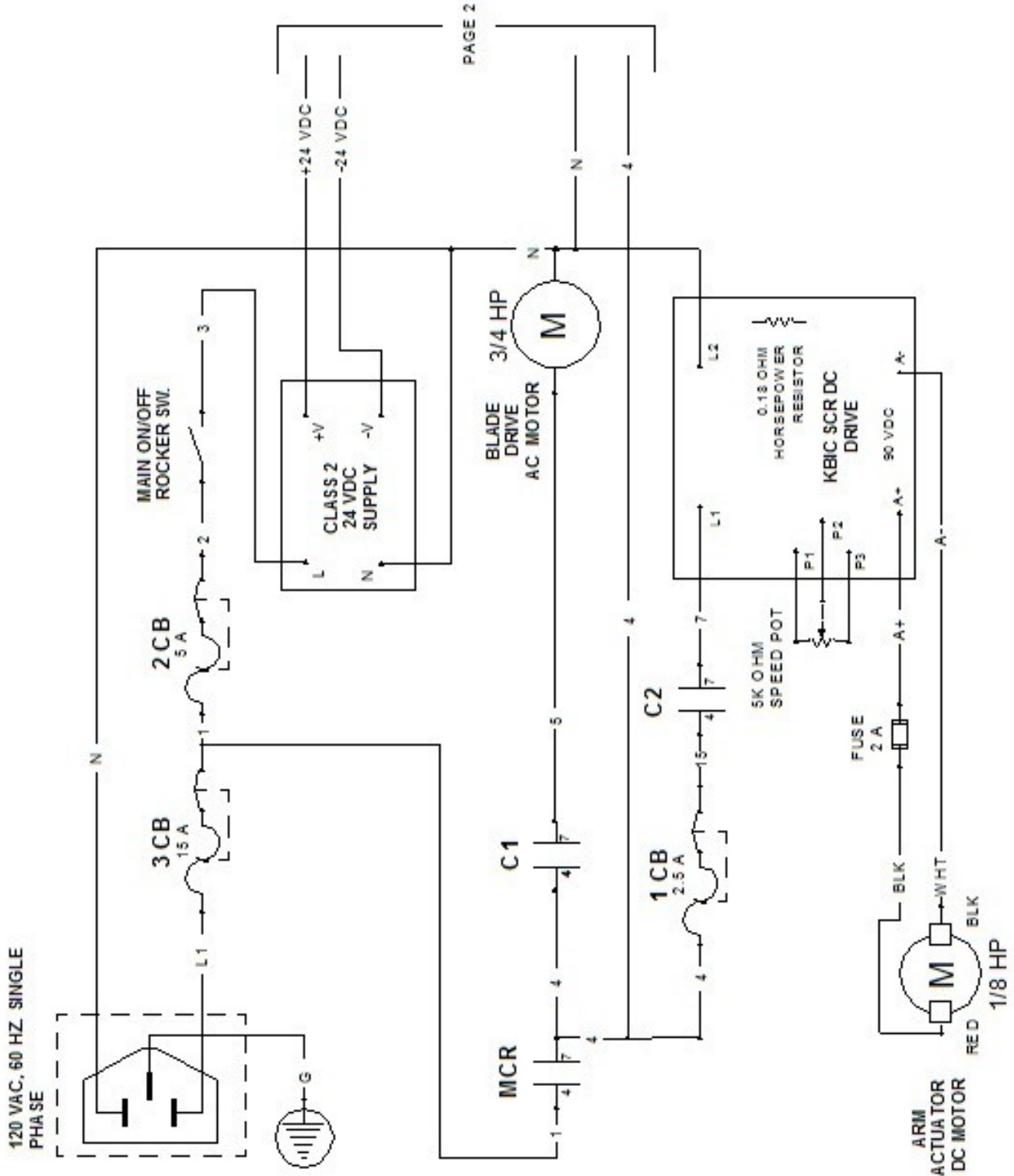

PAGE 2



2005 VARIABLE THICKNESS BREAD SLICER

WIRE DIAGRAM 1-60-115 PAGE 2 OF 3

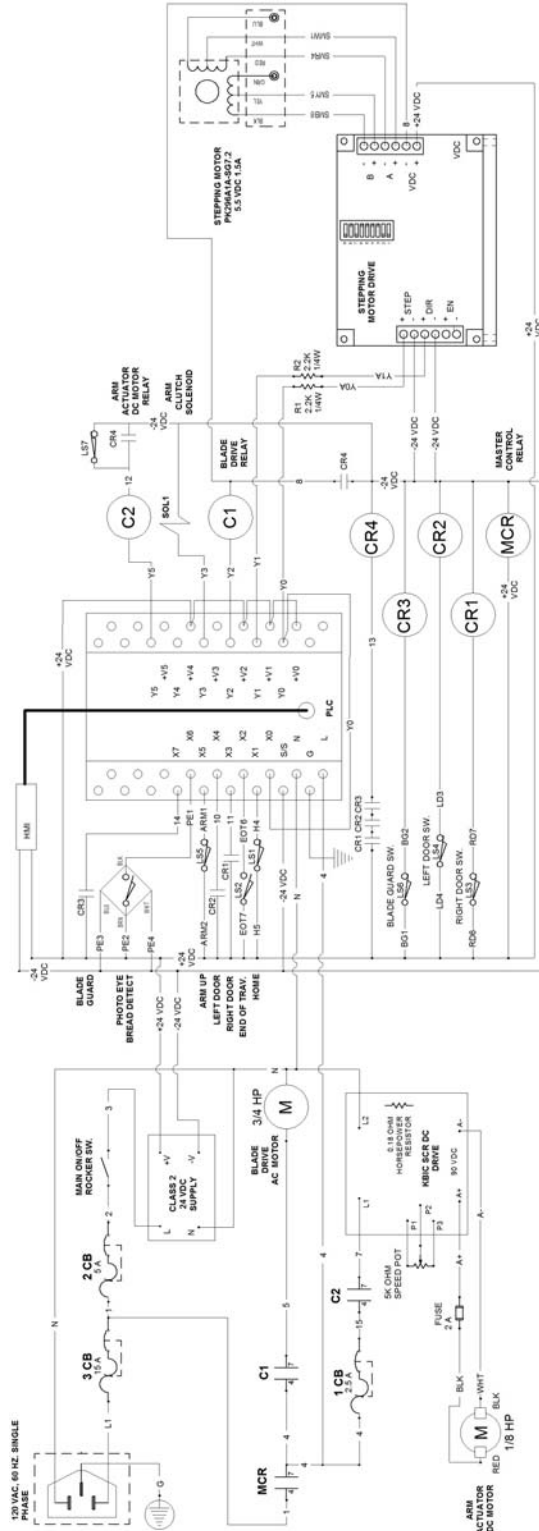



2005 VARIABLE THICKNESS BREAD SLICER

WIRE DIAGRAM 1-60-115 PAGE 3 OF 3

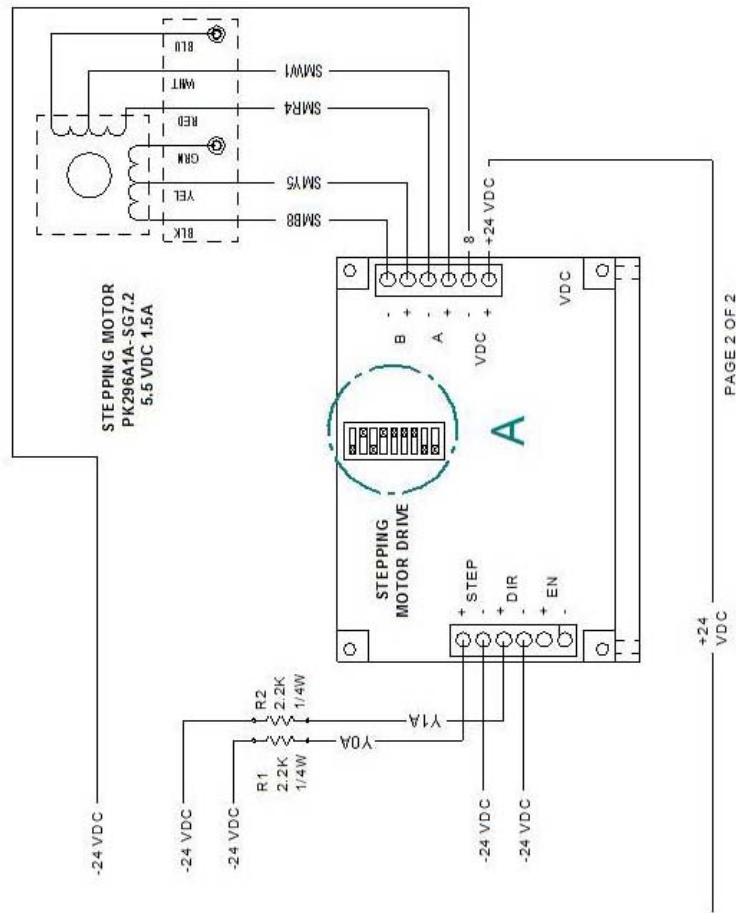
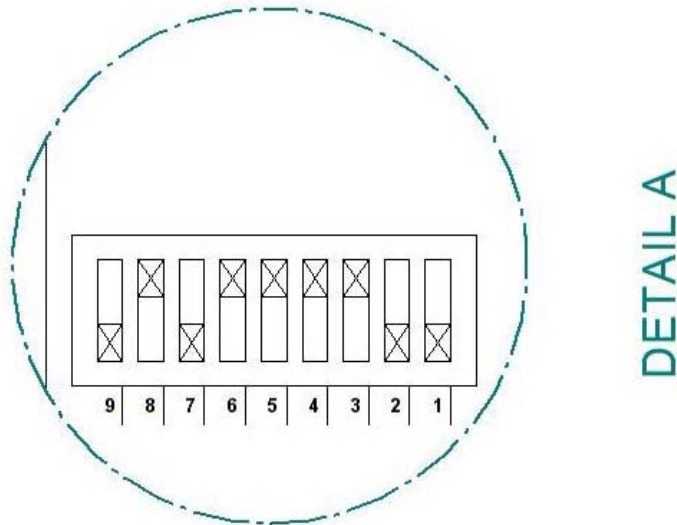

REV. 11-1-13



WARRANTY

PARTS

Oliver Packaging & Equipment Company warrants that if any part of the equipment (other than a part not manufactured by Oliver Packaging & Equipment) proves to be defective (as defined below) within one year after shipment, and if Buyer returns the defective part to Oliver Packaging & Equipment within one year, Freight Prepaid to Oliver Packaging & Equipment plant in Grand Rapids, MI, then Oliver Packaging & Equipment , shall, at Oliver Packaging & Equipment option, either repair or replace the defective part, at Oliver Packaging & Equipment expense.

LABOR

Oliver further warrants that equipment properly installed in accordance with our special instructions, which proves to be defective in material or workmanship under normal use within one (1) year from installation or one (1) year and three (3) months from actual shipment date, whichever date comes first, will be repaired by Oliver Packaging & Equipment or an Oliver Packaging & Equipment Authorized Service Dealer, in accordance with Oliver Packaging & Equipment published Service Schedule.

For purposes of this warranty, a defective part or defective equipment is a part or equipment which is found by Oliver Packaging & Equipment to have been defective in materials workmanship, if the defect materially impairs the value of the equipment to Buyer. Oliver Packaging & Equipment has no obligation as to parts or components not manufactured by Oliver Packaging & Equipment, but Oliver Packaging & Equipment assigns to Buyer any warranties made to Oliver Packaging & Equipment by the manufacturer thereof.

This warranty **does not** apply to:

1. Damage caused by shipping or accident.
2. Damage resulting from improper installation or alteration.
3. Equipment misused, abused, altered, not maintained on a regular basis, operated carelessly, or used in abnormal conditions.
4. Equipment used in conjunction with products of other manufacturers unless such use is approved by Oliver Packaging & Equipment Company in writing.
5. Periodic maintenance of equipment, including but not limited to lubrication, replacement of wear items, and other adjustments required due to installation, set up, or normal wear.
6. Losses or damage resulting from malfunction.

The foregoing warranty is in lieu of all other warranties expressed or implied AND OLIVER PACKAGING & EQUIPMENT COMPANY MAKES NO WARRANTY OF MERCHANTABILITY OR FITNESS FOR PURPOSE REGARDING THE EQUIPMENT COVERED BY THIS WARRANTY. Oliver Packaging & Equipment Company neither assumes nor authorizes any person to assume for it any other obligations or liability in connection with said equipment. OLIVER PACKAGING & EQUIPMENT COMPANY SHALL NOT BE LIABLE FOR LOSS OF TIME, INCONVENIENCE, COMMERCIAL LOSS, INCIDENTAL OR CONSEQUENTIAL DAMAGES.



Oliver Packaging and Equipment Company
3236 Wilson DR NW Walker, MI 49534

(800) 253-3893
www.oliverquality.com

WARRANTY PROCEDURE

1. If a problem should occur, either the dealer or the end user must contact the Parts and Service Department and explain the problem.
2. The Parts and Service Manager will determine if the warranty will apply to this particular problem.
3. If the Parts and Service Manager approves, a Work Authorization Number will be generated, and the appropriate service agency will perform the service.
4. The service dealer will then complete an invoice and send it to the Parts and Service Department at Oliver Packaging & Equipment Company.
5. The Parts and Service Manager of Oliver Packaging and Equipment Company will review the invoice and returned parts, if applicable, and approve for payment.



Oliver Packaging and Equipment Company
3236 Wilson DR NW Walker, MI 49534

(800) 253-3893
www.oliverquality.com

RETURNED PARTS POLICY

This policy applies to all parts returned to the factory whether for warranted credit, replacement, repair or re-stocking.

Oliver Packaging and Equipment Company requires that the customer obtain a Return Material Authorization (RMA) number before returning any part. This number should appear on the shipping label and inside the shipping carton as well. All parts are to be returned prepaid. Following this procedure will insure prompt handling of all returned parts.

To obtain an RMA number contact the Repair Parts Department toll free at (800) 253-3893.

Parts returned for re-stocking are subject to a **RE-STOCKING CHARGE**.

Thank you for your cooperation,

Repair Parts Manager
Oliver Packaging and Equipment Company