



Walker, Michigan, U.S.A. 49534-7564

**USER'S OPERATING AND INSTRUCTION MANUAL**

**MODEL 797-32, 797-48 & 797-PB**

BREAD SLICERS



## 797 Series of Slicers

### INDEX

<u>Section Description</u>	<u>Document No.</u>	<u>Page No.</u>
SAFETY INSTRUCTIONS -----	0797S20063 -----	1-1
DESCRIPTION/SPECIFICATIONS -----	0797S20064 -----	2-1
Description -----		2-1
Specifications -----		2-1
INSTALLATION INSTRUCTIONS -----	0797S20065 -----	3-1
Removing the Slicer from the Shipping Skid -----		3-1
Installing Optional Casters -----		3-2
OPERATING INSTRUCTIONS -----	0797S20067 -----	4-1
Adjusting the Gravity Feed Slicer		



**797 Series of Slicers**

**INDEX (Continued)**

REPLACEMENT PARTS SECTION (Continued)

<u>Section Description</u>	<u>Document No.</u>	<u>Page No.</u>
BASE/CASTER & FEET -----	0797S20072 -----	9-1
Drawing -----		9-1
Parts List -----		9-2
SLICE PARTS & HOLDDOWN -----	0797S20073 -----	10-1
Drawing -----		10-1
Parts List -----		10-2
32 & 48 INCH GRAVITY INFEED CHUTES -----	0797S20074 -----	11-1
Drawing -----		11-1
Parts List -----		11-2
GRAVITY INFEED CHUTES WITH GUARD -----	0797S20100 -----	12-1
Drawing -----		12-1
Parts List -----		12-2
Wiring Diagram -----		12-3
48 INCH POWERBELT INFEED CHUTE -----	0797S20075 -----	13-1
Drawing -----		13-1
Parts List -----		13-2
DRIVEN PULLEY -----	0797S20076 -----	14-1
Drawing -----		14-1
Parts List -----		14-2
STANDARD OUTFEED -----	0797S20077 -----	15-1
Drawing -----		15-1
Parts List -----		15-2
BAGGER OUTFEED -----	0797S20078 -----	16-1
Drawing -----		16-1
Parts List -----		16-2
CURVED OUTFEED -----	0797S20079 -----	17-1
Drawing -----		17-1
Parts List -----		17-2
SINGLE PHASE ELECTRICAL -----	0797S20080 -----	18-1
Wiring Diagram -----		18-1
Drawing -----		18-1
Parts Lists -----		18-2
Rev. 5-1-06		Continued



**797 Series of Slicers**

***INDEX (Continued)***

REPLACEMENT PARTS SECTION

<u>Section Description</u>	<u>Document No.</u>	<u>Page No.</u>
THREE PHASE ELECTRICAL -----	0797S20081 -----	19-1
Wiring Diagram -----		19-1
Drawing -----		19-1
Parts Lists -----		19-2
WARRANTY -----	GEN 040228	
WARRANTY PROCEDURE -----	GEN 040226	
RETURNED PARTS POLICY -----	GEN 040227	



---

---

## 797 Series of Slicers

---

---

### SAFETY INSTRUCTIONS

#### **WARNING**

**VARIOUS SAFETY DEVICES AND METHODS OF GUARDING HAVE BEEN PROVIDED ON THIS MACHINE. IT IS ESSENTIAL HOWEVER THAT THE MACHINE OPERATORS AND MAINTENANCE PERSONNEL OBSERVE THE FOLLOWING SAFETY PRECAUTIONS. IMPROPER INSTALLATION, MAINTENANCE, OR OPERATION OF THIS EQUIPMENT COULD CAUSE SERIOUS INJURY OR DEATH.**

1. Read this manual before attempting to operate your machine. Never allow an untrained person to operate or service this machine.
2. Connect the machine to a properly grounded electrical supply that matches the requirements shown on the electrical specification plate and follow all specifications of local electrical codes.
3. Disconnect and lock-out the machine from the power supply before cleaning or servicing.
4. Check and secure all guards before starting the machine.
5. Observe all caution and warning labels affixed to the machine.
6. Use only proper replacement parts.
7. Do not wear loose fitting clothing or loose hair when working near this machine. Shirt tails should be tucked in.
8. Wear proper, personal, protective, safety equipment.
9. Keep Hands away from the moving parts of this machine while it is in operation.
10. In addition to these general safety instructions, please follow the more specific safety instructions in the rest of this operating instruction manual.

#### **WARNING**

**DO NOT USE FOR OTHER THAN ORIGINALLY INTENDED PURPOSE.**



## 797 Series of Slicers

### DESCRIPTION/SPECIFICATIONS

#### Description

The Oliver Model 797 series of Bread Slicers are of a compact, sturdy, time tested design, which has been used in bakeries worldwide for many years. The machine is easy to operate, with its gravity fed infeed chute, allowing production slicing of product in quantities of up to 600 loaves per hour. Speed is of course dependent on condition of the machine, sharpness of its knives and the texture of the actual product being sliced. Its design will provide years of efficient, trouble-free operation requiring a minimum of maintenance.

The Model 797 series of Bread Slicers are of stainless, plated, and painted steel construction for easy cleaning and maintenance. Most operators will be able to replace the knives without the need of a service call.

Oliver Packaging and Equipment, who has a reputation of serving the Baking Industry for well over 60 years, backs these slicers.

#### Specifications

**Space Requirements: Model 797-32, (All Dimensions are Approximate)**

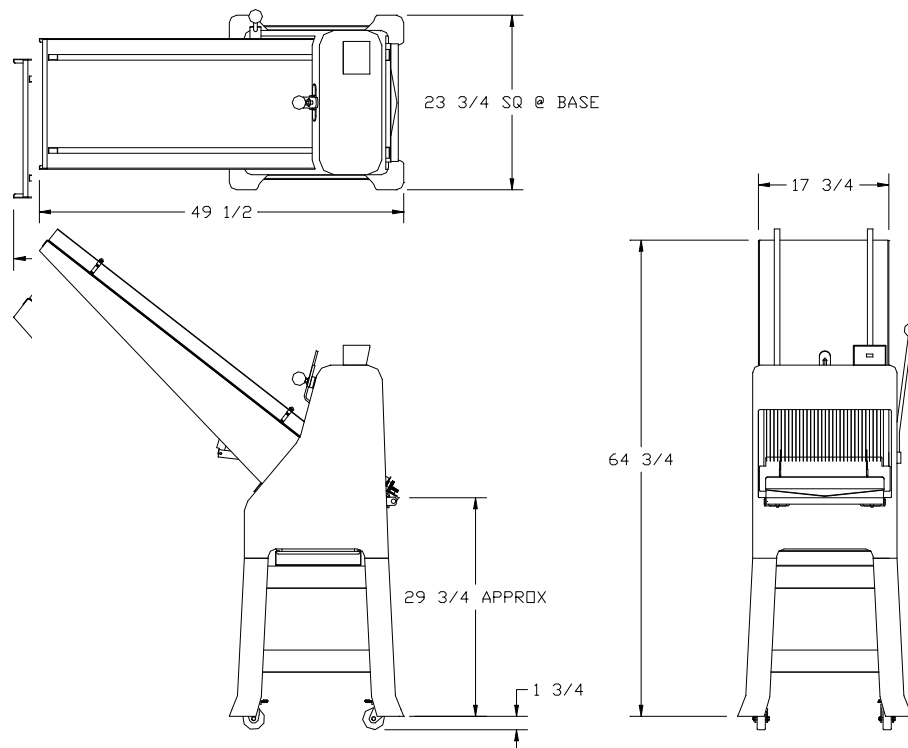



## 797 Series of Slicers

### DESCRIPTION/SPECIFICATIONS

#### Description

The Oliver Model 797 series of Bread Slicers are of a compact, sturdy, time tested design, which has been used in bakeries worldwide for many years. The machine is easy to operate, with its gravity fed infeed chute, allowing production slicing of product in quantities of up to 600 loaves per hour. Speed is of course dependent on condition of the machine, sharpness of its knives and the texture of the actual product being sliced. Its design will provide years of efficient, trouble-free operation requiring a minimum of maintenance.

The Model 797 series of Bread Slicers are of stainless, plated, and painted steel construction for easy cleaning and maintenance. Most operators will be able to replace the knives without the need of a service call.

Oliver Packaging and Equipment, who has a reputation of serving the Baking Industry for well over 60 years, backs these slicers.

#### Specifications

**Space Requirements: Model 797-32, (All Dimensions are Approximate)**

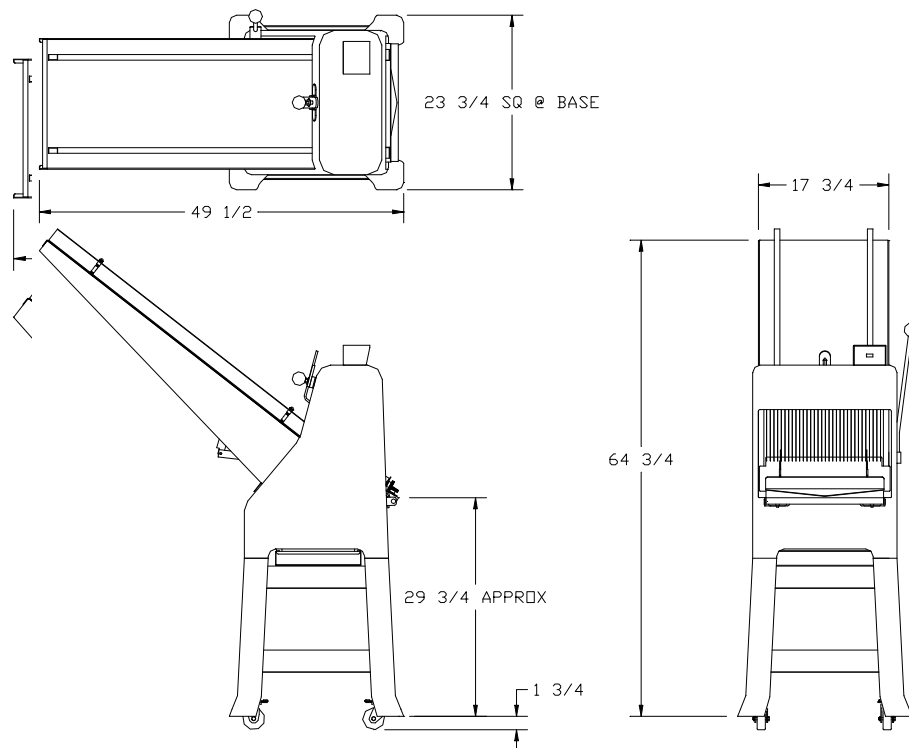



## 797 Series of Slicers

### Space Requirements: **Model 797-PB,**

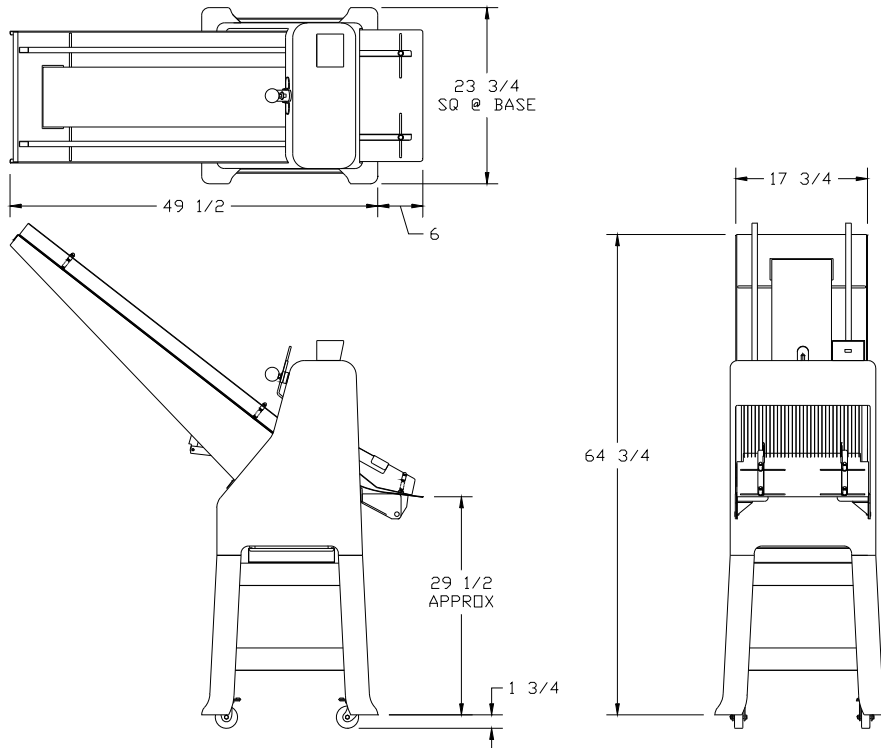

### Product Capacities:

Up to 16 inches long and in the range of 2 to 5 inches high.

*Standard Electrical Options: (Others available at additional cost -- consult factory).*

- 1 phase, 60 hz, 115VAC, 7 Amps.
- 1 phase, 60 hz, 230VAC, 3.5 Amps.

### Standard Slice Spacings

7/16, 1/2, 9/16 (inches)

*Optional Slice Spacings, (At additional cost). (Specials available -- consult factory).*

5/16, 3/8, 5/8, 11/16, 3/4, 13/16, 7/8, 1, 1-1/4 (inches)

### Shipping Weight, (All Weights are Approximate)

- 797-32 = 320 lbs.
- 797-48 = 380 lbs.
- 797-PB = 450 lbs.





## 797 Series of Slicers

### CASTER INSTALLATION INSTRUCTIONS

Place blocks on the floor approximately (8) and (38) inches from the discharge side of the slicer, see the illustration below. Lower the holddown to its lowest position and tighten the adjustment knob to prevent the outfeed table from swinging out. With one person on each side of the slicer, gently lower the slicer onto the blocks.

### CAUTION

**NEVER ATTEMPT TO LIFT THE SLICER BY ITS INFEED CHUTE AS DAMAGE TO THE MACHINE MAY RESULT.**

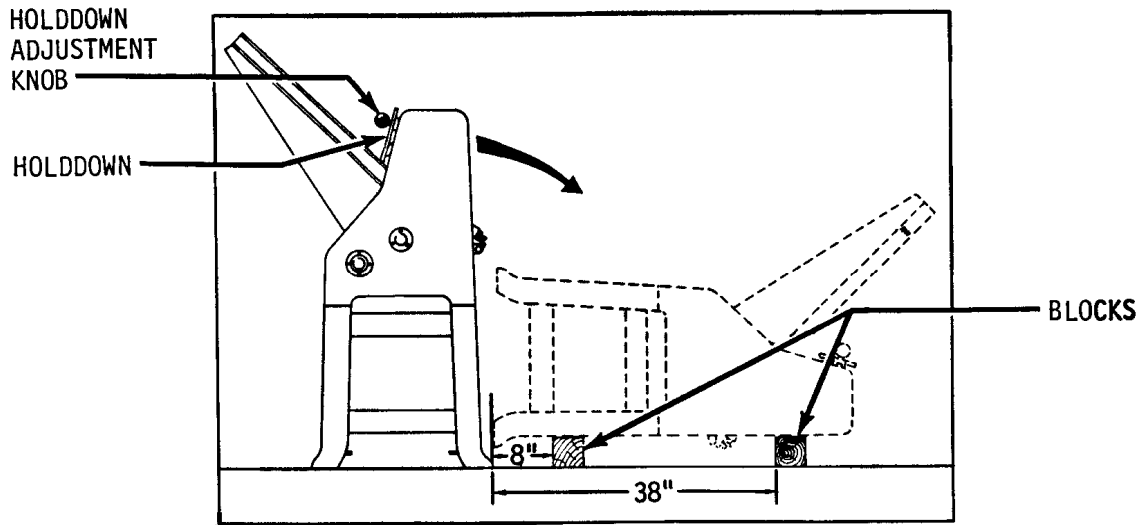

Locate the casters, 1/4-inch bolts, lock washers, and nuts in the option package. Install the casters using the furnished hardware as shown in the figure on the next page tighten the bolts and nuts securely using two wrenches. Install both locking casters on the discharge side of the machine. See the next illustration. Set the brakes tightly on both locking casters, (this will help to keep the wheels from rolling when lifting the slicer back to its upright position).

Install the two rigid casters in the same manner on the infeed side of the slicer.

Rev. 8/3/04



## 797 Series of Slicers

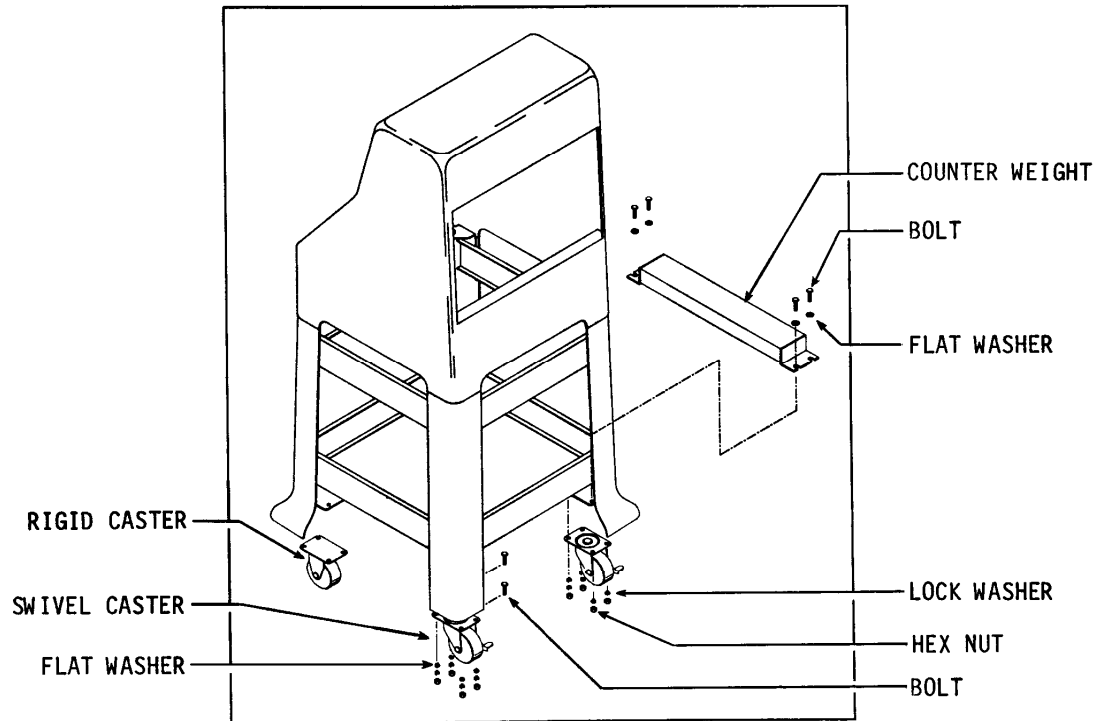

On all slicers equipped with either the Power Belt infeed chute option, or a Model 1179S bagger, a counter weight must be attached to the caster brackets on the right hand side of the machine, (as viewed from the outfeed side of the slicer). See the above illustration. This counter weight must not be removed. Use the same hardware used to secure the weight to attach the casters when both are used. Add additional bolts, washers and nuts on those caster plate holes not involved with the weight mounted as shown. Install one rigid caster and one swivel caster on the right hand side of the machine, (the weight side). Remember, the rigid casters must be installed on the infeed side of the machine.

Install the remaining two casters as previously described, setting their brakes tightly.

After completing the installation, chock the locked wheels using a 2 x 4 to ensure that they will not roll or skid when lifting the slicer back to the upright position. Once the machine is upright release the brakes and roll the slicer to its desired location.

Rev. 8/3/04



## 797 Series of Slicers

### OPERATING INSTRUCTIONS

#### **CAUTION**

**ALWAYS USE CARE WHENEVER WORKING NEAR THE CUTTING KNIVES.**

#### *Adjusting the Gravity Feed Slicer's Holddown*

Loosen the holddown adjustment knob. Adjust the holddown so that the product just clears the bottom edge of the holddown as it passes through the cutting knives. Tighten the holddown adjustment knob when the holddown is in the desired location. See the illustration below. Proper adjustment of the holddown will prevent the product from jumping as it passes through the cutting knives increasing cutting efficiency.

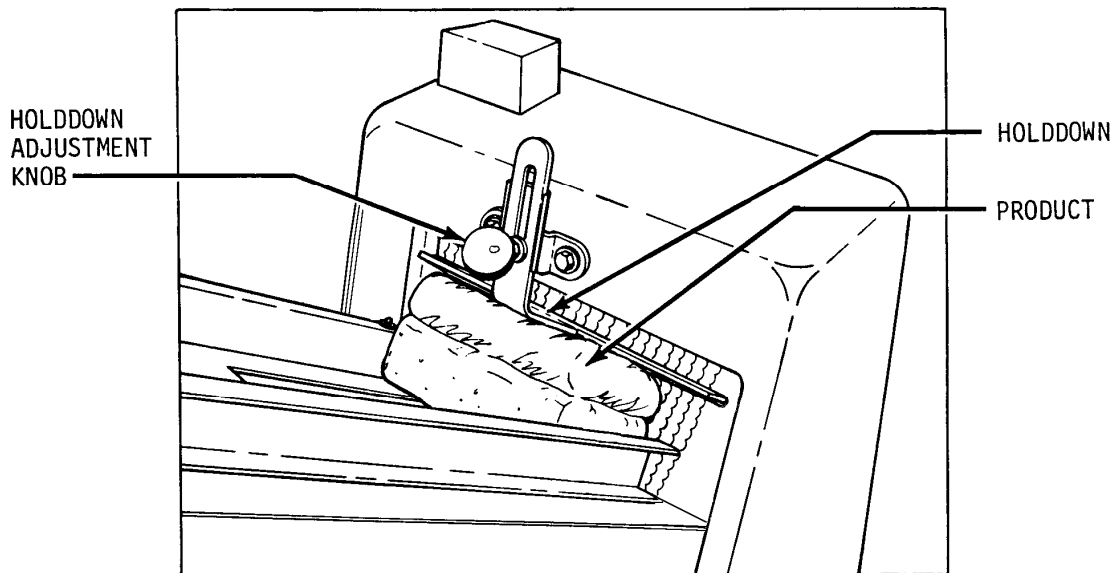



---

---

## 797 Series of Slicers

---

---

### *Adjusting the Slicer for Product Length*

Using a typical product, adjust the infeed chute side guides by applying hand pressure. See the next illustration. Set the side guides approximately 1/8 inch wider than the longest expected product.

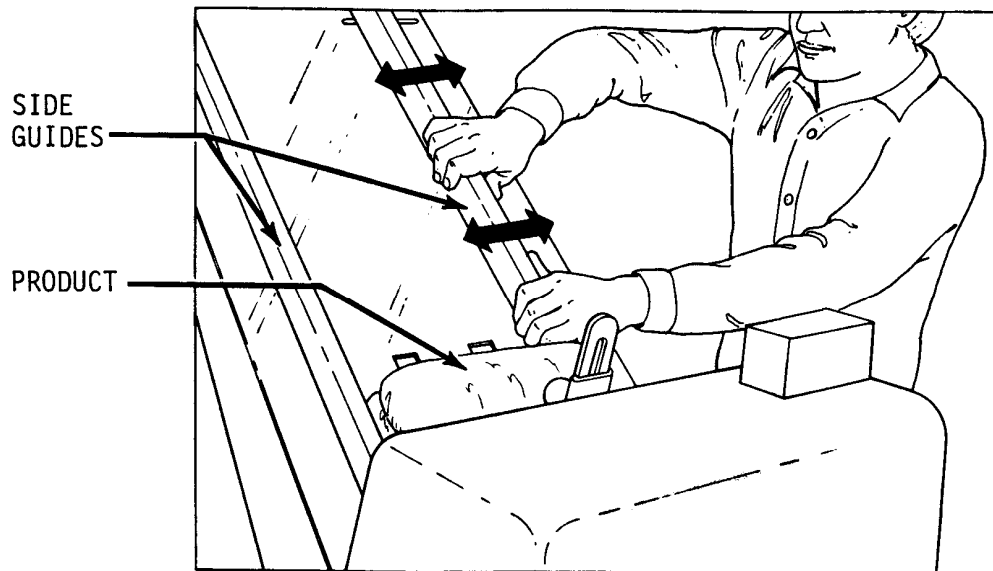

### *Adjusting the Outfeed Side Guides on a Standard Outfeed Table*

Adjust the side guide extensions so that they are approximately 1/4 inch from the cutting knives. Loosen the outfeed guide adjustment knobs. Adjust the outfeed side guides to align with the infeed guides. See the illustration, which follows. Once satisfied with the location re-tighten the side guide adjustment knobs. Proper adjustment of these guides will keep the end slices from falling over as the product exits the cutting knives.



## 797 Series of Slicers

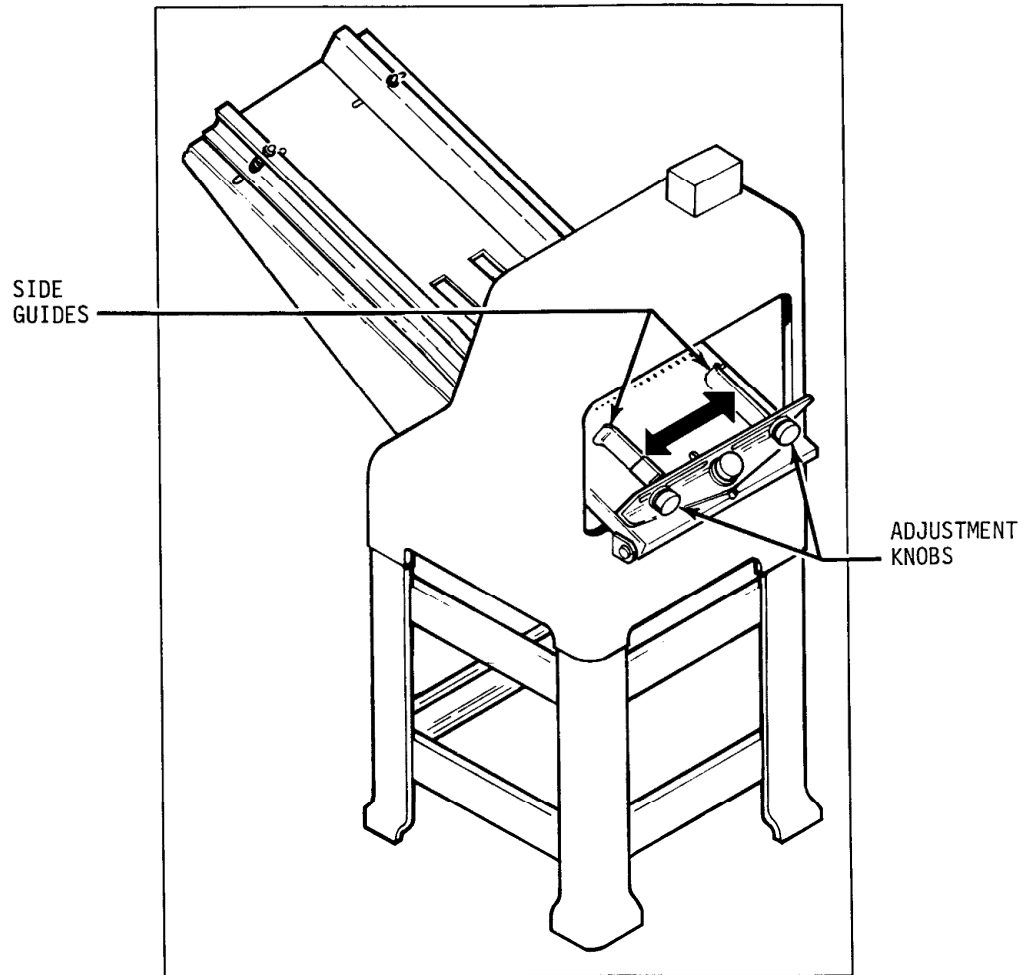

### NOTE

**OPTIONAL OUTFEED TABLE GUIDES ARE ADJUSTED WITH HAND PRESSURE IN A FASHION SIMILAR TO THAT OF THE INFEED GUIDES. AS WITH THE STANDARD OUTFEED TABLE ALIGN THE OUTFEED GUIDES WITH THE INFEED GUIDES.**

#### *Operating a Gravity Feed Slicer*

Once the slicer has been properly adjusted for product clearance, the infeed chute may be loaded with the product to be sliced. Flipping the starting switch to the **ON** position will begin operation. Remove each sliced product from the discharge table as it is sliced.



## 797 Series of Slicers

### **NOTE**

**THE GRAVITY FEED SLICER'S OPTIMUM OPERATING EFFICIENCY WILL BE MAINTAINED BY ENSURING THAT THE INFEED CHUTE IS KEPT FULLY LOADED. THE ACTUAL SPEED OF SLICING IS DEPENDENT ON THE NUMBER OF PRODUCTS IN POSITION ON THE INFEED CHUTE, SHARPNESS OF CUTTING KNIVES, AND TEXTURE OF THE PRODUCT.**

#### *Operating the Gravity Feed's Lever Actuated Last Loaf Pusher*

32 inch and 48 inch gravity feed slicers are often equipped with a lever actuated last loaf pusher; this pusher is used to assist in feeding the last product on the infeed chute into the cutting knives. To operate the last loaf pusher, slowly pull the last loaf pusher lever toward the discharge side of the slicer. See the next illustration. Return the lever to the upper position before reloading the infeed chute.

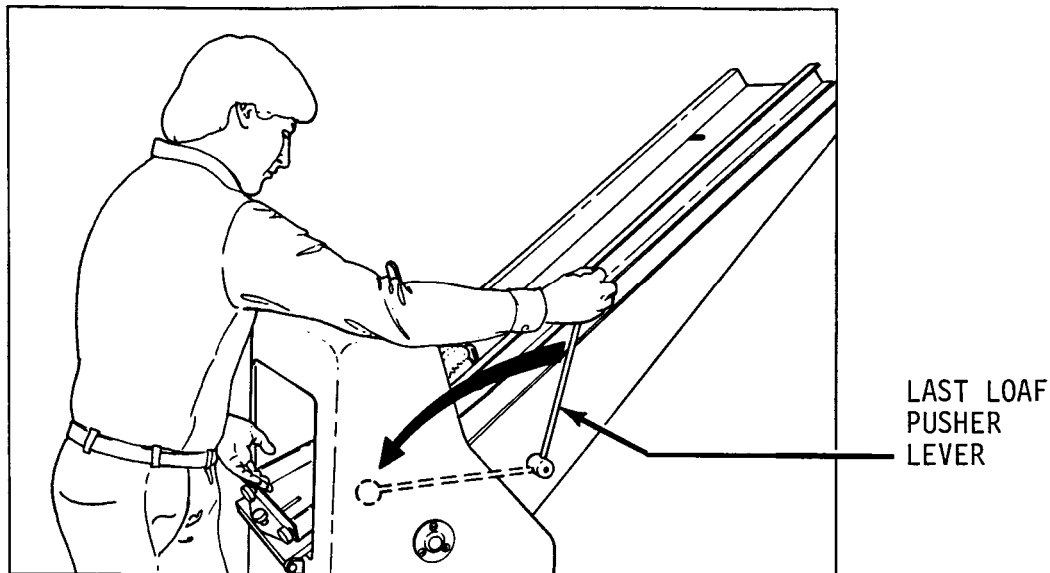

**Operating the Gravity Feed's Lever Actuated Last Loaf Pusher**

### **CAUTION**

**THE KNIVES ARE EXTREMELY SHARP.  
DO NOT TOUCH MOVING OR STATIONARY KNIVES.**

Once the last loaf pusher has fed the product into the cutting knives as far as it can, it may be necessary to pull the product the rest of the way through the knives by hand.



---

---

## 797 Series of Slicers

---

---

### TROUBLESHOOTING

#### **WARNING**

**ALWAYS DISCONNECT THE SLICER FROM THE POWER SUPPLY BEFORE ATTEMPTING ANY TYPE OF MAINTENANCE TASK, INCLUDING TROUBLESHOOTING.**

#### *The Slicer Will Not Start (Motor Is Not Humming)*

- The machine is not plugged in.
- There is no power at the outlet. (Check by plugging in a small working appliance, like a lamp. Check to see if a circuit breaker has tripped. If the circuit breaker has not tripped and the circuit is still not working have a qualified electrician check the circuit.)
- The motor switch overload has tripped. (To reset push firmly in the direction shown on the switch nameplate.)
- There are breadcrumbs in the motor starting switch. (Have a qualified electrician disassemble the switch and clean it.)
- The problem is somewhere in the electrical system of the machine. (Have a qualified electrician find and repair the problem.)

#### *The Slicer Will Not Start (Motor Is Humming)*

#### **CAUTION**

**DO NOT ALLOW THE MOTOR TO HUM WITHOUT STARTING.  
OVERHEATING CAN PERMANENTLY DAMAGE THE MOTOR.**

- The motor has failed. (Have it checked by a qualified electrician.)

#### **NOTE**

**A SPECIAL NON-VENTILATED MOTOR MUST BE USED WITH THIS SLICER.**

- The drive system is binding. (Have a qualified service agent check for defective bearings or other restrictions to free movement.)



Oliver Packaging & Equipment Company  
3236 WISON DR NW WALKER MI. 49534

(800) 253-3893  
www.oliverquality.com

---

---

### 797 Series of Slicers

---

---

- There is mechanical interference between other parts of the slicer. (Have a qualified service agent evaluate the machine for adjustment or replacement of defective parts.)

#### *Bread Slices Vary in Thickness*

- The blade frames are out of adjustment. (See the





---

---

## 797 Series of Slicers

---

---

### MAINTENANCE

### WARNING

**ALWAYS DISCONNECT THE SLICER FROM THE POWER SUPPLY BEFORE ATTEMPTING ANY TYPE OF MAINTENANCE TASK.**

#### *Cleaning*

Use a mild detergent solution to clean all exterior surfaces and empty the crumb tray daily or more often if necessary. Periodically swing out the discharge table to allow access to the drive area of the machine, then brush, blow, (if compressed air is available), or wipe all foreign material from all surfaces, especially from moving parts.

#### *Lubrication*

Once a month, more often during heavy use, put a drop of food approved lubricant on each of the pivot points, of the plastic links, at the top to the blade frames. All other bearings are either grease packed or sealed and seldom need attention.

### CAUTION

**NEVER OIL OR GREASE THE MOTOR.**



## 797 Series of Slicers

### Removing the Blade Frames

## **WARNING**

**ALWAYS DISCONNECT THE SLICER FROM THE POWER SUPPLY BEFORE ATTEMPTING ANY TYPE OF MAINTENANCE TASK.**

Swing out the discharge table from the slicer. See the next illustration.

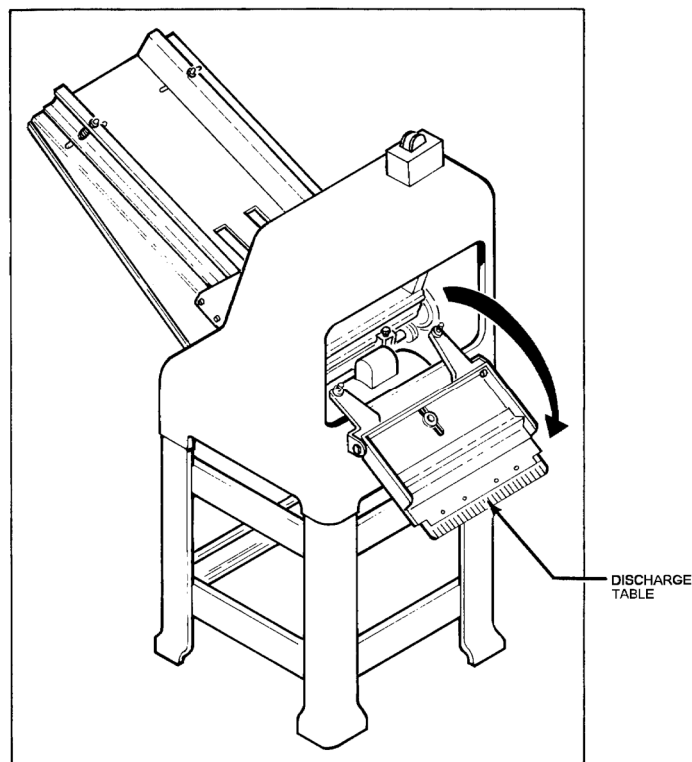

Always start by removing the discharge side blade frame first. Both blade frames should be removed from the discharge side of the machine, (see the note below). You should remove the discharge side blade frame completely from the machine before starting on the infeed side blade frame. However each is removed using similar procedures.

## **NOTE**

**ON MACHINES EQUIPPED WITH POWER BELT INFEEDS, THE INFEED SIDE BLADE FRAME IS NOT REMOVED. A SPECIAL BLADE CHANGING TOOL IS PROVIDED ON NEW MACHINES WHICH ALLOWS CHANGING OF THE BLADES, IN THE MACHINE.**



---

---

## 797 Series of Slicers

---

---

*Removing the Blade Frames (Continued)*

<b>NOTE</b>
-------------

**NEVER LOOSEN THE NUTS ON THE ECCENTRIC PINS OR ATTEMPT TO REMOVE THEM TO AID IN REMOVING THE BLADE FRAMES.**

Start by pulling the hairpin clip from the eccentric pin, located at the top of each blade frame, see illustration below, then slide the top link toward the eccentric pin



## 797 Series of Slicers

### Removing the Blade Frames (Continued)

## CAUTION

**THE BLADES ARE EXTREMELY SHARP.  
ALWAYS HANDLE BLADE FRAMES WITH CARE.**

The blade frame can now be carefully lifted from the slicer. See below.

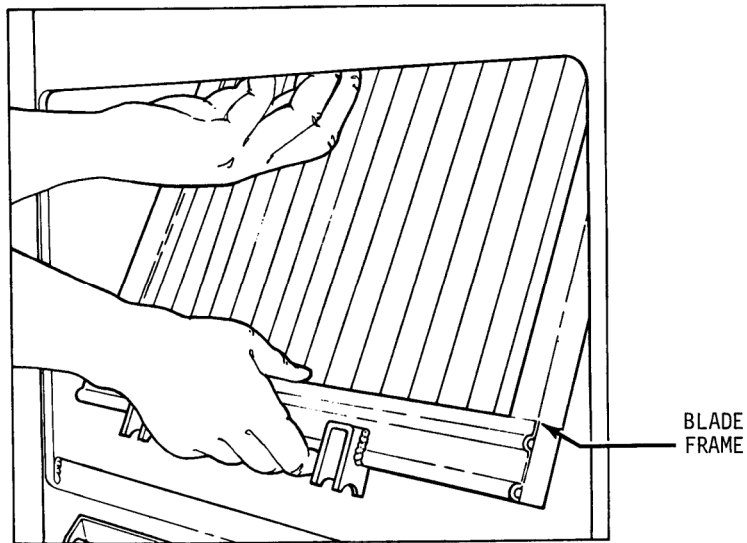

Removal of the infeed side blade frame is accomplished in a similar fashion. However the chute guard must first be removed by removing the four knobs which hold it in place this will allow access to the locking cams. See the illustration below.

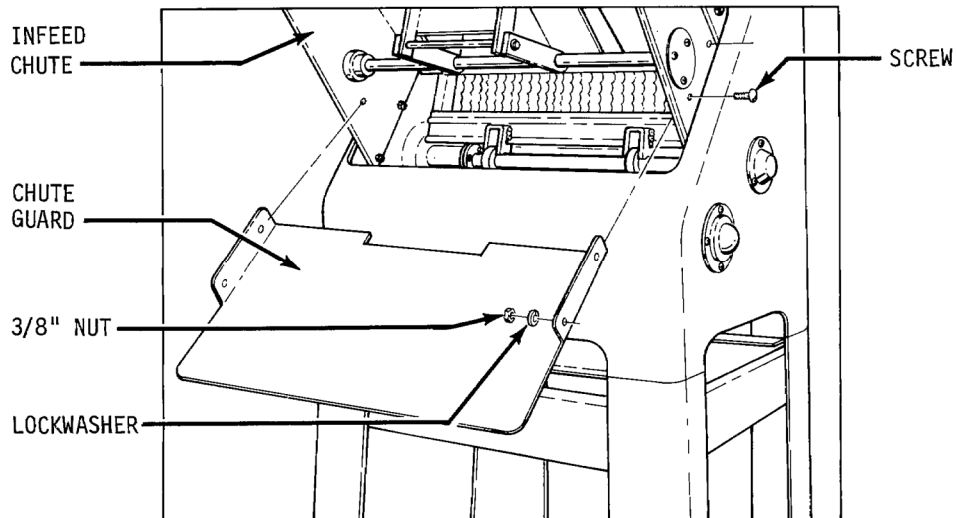



---

---

## 797 Series of Slicers

---

---

### *Changing the Blades*

#### **WARNING**

**ALWAYS DISCONNECT THE SLICER FROM THE POWER SUPPLY BEFORE ATTEMPTING ANY TYPE OF MAINTENANCE TASK.**

#### **CAUTION**

**THE BLADES ARE EXTREMELY SHARP. ALWAYS HANDLE THEM WITH CARE.**

#### **NOTE**

**DO NOT INTERCHANGE THE TWO BLADE FRAMES. REPLACE THE BLADE FRAME TO THE SAME SIDE OF THE MACHINE AS IT WAS TAKEN FROM**

#### **NOTE**

**WHEN CHANGING BLADES FIRST NOTE THE DIRECTION THE SHARPENED EDGES ARE FACING ON THE BLADE FRAME. THEY ARE FACING UP ON ONE FRAME AND DOWN ON THE OTHER. DO NOT CHANGE THIS DIRECTION.**

Place the blade frame on a flat surface. You may use the special knife tool, shown in the illustration on the next page, or use a common set of pliers to depress the spring-loaded pin holding each knife. This will reduce the tension on the knife so that it may be easily removed.

In the illustration on the next page you can see the use of the knife tool. It is inserted into the blade frame on the spring-loaded pin end and then by lifting up on the tool it will deflect the pin reducing the tension on the knife. Once this has been done the knife can be carefully removed.



## 797 Series of Slicers

### Changing the Blades (Continued)

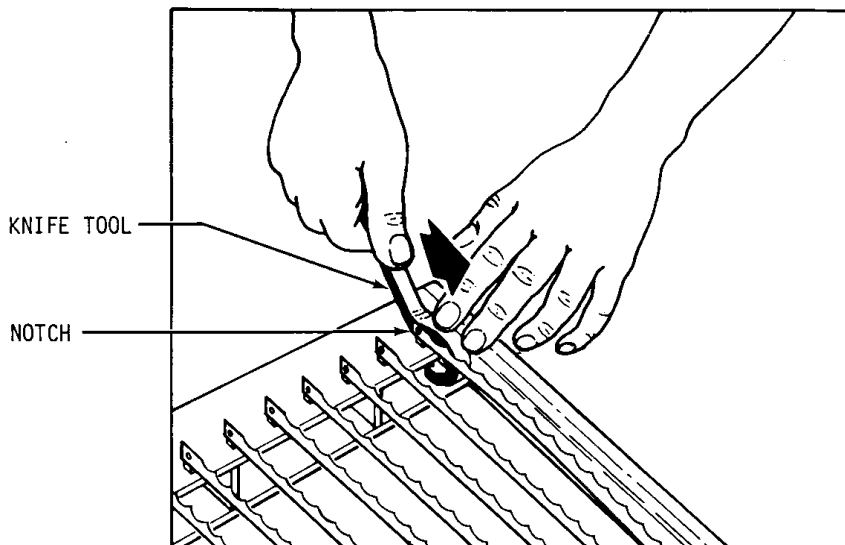

The new knife can be installed by reversing the removal procedure. A paper clip can be used to hold the knife in position on the lower pin to ease installation. See the illustration below.

### **NOTE**

**WHEN REPLACING ALL THE KNIVES, ALWAYS REMOVE THE CENTER KNIVES FIRST AND WORK TOWARD THE ENDS. INSTALL THE NEW KNIVES AT THE ENDS FIRST AND WORK ALTERNATELY TOWARD THE CENTER.**

### **CAUTION**

**NEVER PUT BLADE FRAMES IN THE SLICER WITHOUT KNIVES.**

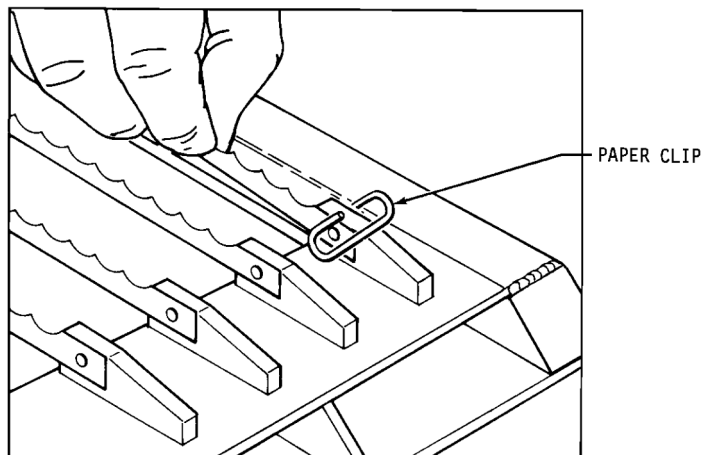



## 797 Series of Slicers

### Tightening the Belt

## WARNING

**ALWAYS DISCONNECT THE SLICER FROM THE POWER SUPPLY BEFORE ATTEMPTING ANY TYPE OF MAINTENANCE TASK.**

## CAUTION

**OVER-TIGHTENING THE DRIVE BELT  
MAY CAUSE BEARING OR MOTOR FAILURE.**

Remove the crumb tray from the slicer and swing out the discharge table. See the illustration below.

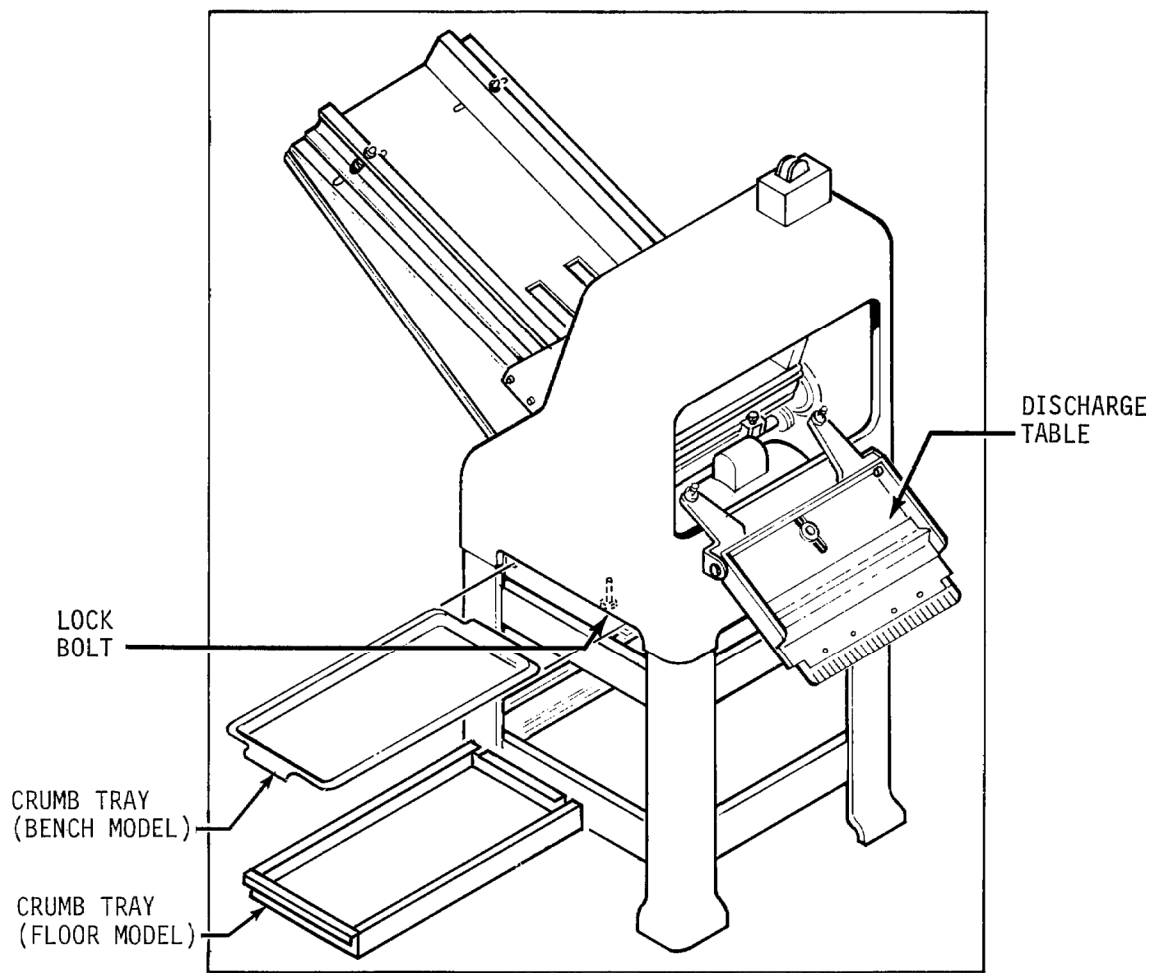



## 797 Series of Slicers

### *Tightening the Belt (Continued)*

Loosen the lockbolt located below the belt adjustment mechanism. See the next illustration. Locate the adjustment bolt below the belt and turn it counter clockwise with a wrench to increase tension on the belt or clockwise to reduce tension on the belt. The drive belt should be just tight enough that, using moderate finger pressure, it would deflect about 3/8 of an inch when pressed midway between the motor drive pulley and the driven pulley. Once the correct tension has been obtained retighten the lockbolt.

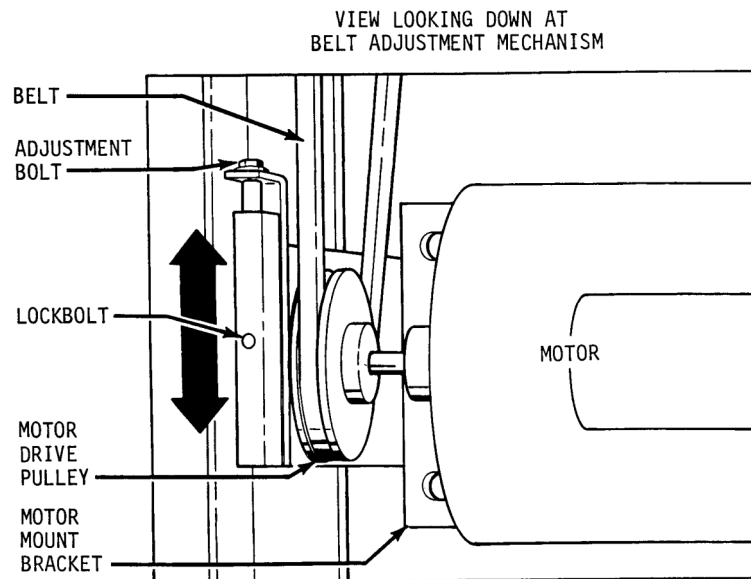





---

---

## 797 Series of Slicers

---

---

*Replacing the Belt*

<b><u>WARNING</u></b>
-----------------------

**ALWAYS DISCONNECT THE SLICER FROM THE POWER SUPPLY BEFORE  
ATTEMPTING ANY TYPE OF MAINTENANCE TASK.**

Referring to the



---

---

## 797 Series of Slicers

---

---

*Adjusting the Blade Frames When Slices Vary in Thickness*

<b><u>WARNING</u></b>
-----------------------

**ALWAYS DISCONNECT THE SLICER FROM THE POWER SUPPLY BEFORE ATTEMPTING ANY TYPE OF MAINTENANCE TASK.**

Swing out the discharge table of the slicer. Loosen, but do not remove the two capscrews which secure the blade frame to the swing shaft, (see below). Using an allen wrench, loosen; but do not remove, the set screw in the fixed collar. Using a ruler, (15



## 797 Series of Slicers

### *Adjusting the Clearance Between the Blade Frames*

## **WARNING**

**ALWAYS DISCONNECT THE SLICER FROM THE POWER SUPPLY BEFORE ATTEMPTING ANY TYPE OF MAINTENANCE TASK.**

The distance between the blade frames is adjusted by rotating the eccentric pins located above the blade frames. Two wrenches are used to do this. One wrench is used to keep the eccentric pin from rotating while the second is used to loosen the lock nut on the end of the pin. This nut secures the pin in position once its proper location is determined. See the illustration below.

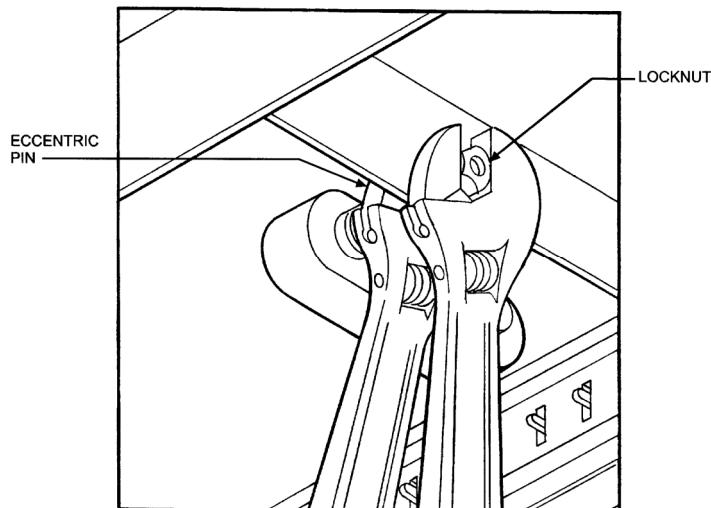

To adjust the eccentric, once the lock nut is loosened, rotate the pin using a wrench, rotating the pin, (it is possible that both pins will need adjustment at the same time), until the knives of the machine are in line, (alternating blades should not appear to be in front of or behind each other when viewed from the side). A straight edge may be used from the dull side of the knives to aid in determining if the knives are in line. When the eccentric pins are in the desired position tighten each of the locknuts to secure the position of the eccentrics. Check the blade frame clearance by turning the driven pulley by hand. Two things may happen if the knives are not inline, the blade frames may hit each other causing a loud knocking noise or the cutting efficiency of the machine may be greatly reduced.



### 797 Series of Slicers

---

---

#### RECOMMENDED SPARE PARTS

<u>PART NUMBER</u>	<u>PART DESCRIPTION</u>	<u>NO. REQ'D</u>
5835-7705	Clip-Hairpin	2
0777-0034	Pin-Eccentric	2
0797-0059-2	Pin-Blade Frame	2
0711-0002	Link-Top	2
5601-1966*	Belt-V 4L36-1/2 (60 Cycle Machines)	1
5709-1125*	Switch-Starter (1 Phase Machines)	1
5220-5001	Bearing-Driven Pulley (With Snap Ring)	1
5220-5040	Bearing-Driven Pulley	1
0797-0058-019	Stud-Driven Pulley	1
6904-6001	Gasket-Driven Pulley	1
0797-0071-4	Rod-Connecting	1
0797-0057-219	Stud-Swing	1
5220-4040	Bearing-Rocker Shaft	2
5220-0042	Bearing-Swing Shaft	4
6301-3609*	Motor-1/2 HP, 1-60-115/230	1
0797-0029-1	Knife-Type A	As Req



### 797 Series of Slicers

## MAIN FRAME/ROCKER ASSEMBLY

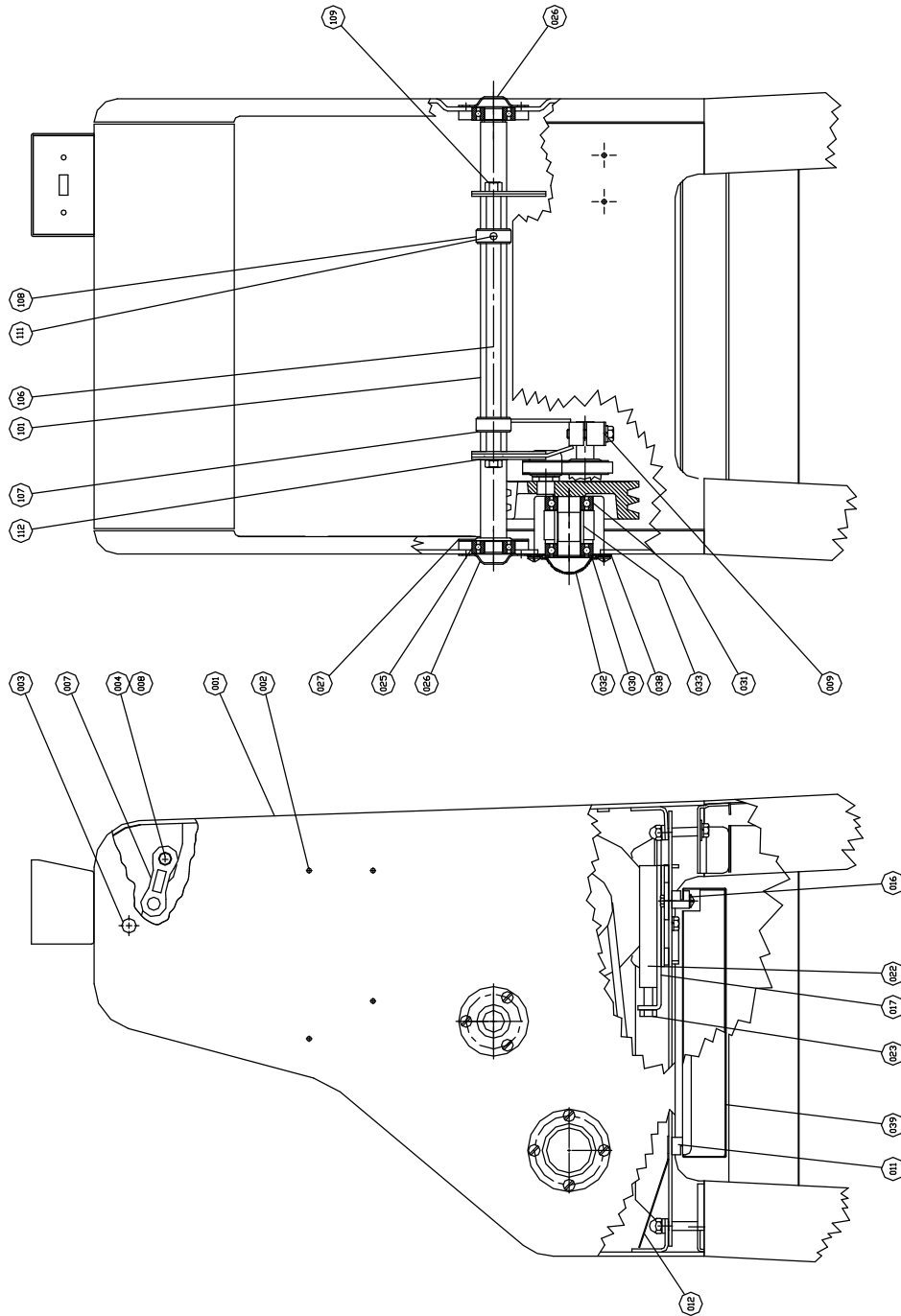

Rev. 4/2/09



## 797 Series of Slicers

### MAIN FRAME/ROCKER PARTS LIST

<u>ITEM NO</u>	<u>PART DESCRIPTION</u>	<u>PART NUMBER</u>
001	FRAME-MAIN	0797-3000
003	PLUG-5/8 HOLE	5769-3005
004	PIN-ECCENTRIC	0777-0034
007	LINK-BLADE FRAME	0711-0002
008	CLIP-HAIRPIN	5835-7705
009	CLAMP-ROCKER	0730-0023
011	SLIDE-DRAWER	0797-0053
012	BAFFLE-CRUMB	0797-0117
016	SLIDE-DRAWER (NOTCHED) (W/O BASE)	0797-0053-001
	SLIDE-DRAWER (NOTCHED) (W/BASE)	0797-0053-004
017	BRACKET-MOTOR	0797-0051-2
022	CLAMP-MOTOR BRACKET	0797-0078-2
023	BOLT-SPECIAL	5842-1532
025	BEARING-BALL	5220-4040
026	CAP-BALL BEARING (OUTSIDE)	4090-0233-0023
027	CAP-POWDER COAT WHITE	4090-0233-0044
030	RING-RETAINNG TRUARC	5840-1040
031	BEARING-BALL	5220-5040
032	CAP-BALL BEARING (DR PULLEY)	4090-0244-0005
038	GASKET-CORK	6904-6001
039	TRAY- CRUMB (W/O BASE)	0797-0054
	TRAY-EXTRA CAP. CRUMB (W/BASE)	0797-3079
101	ROCKER	0732-0012-001
106	SHAFT-SWING	0730-0024-001
107	COLLAR-HOLD DOWN	0797-0031-002
108	COLLAR-LOCATING	0797-0031-003
111	SCREW-SOCKET SET 3/8-16 X 1/4	5842-6156
112	BEARING-BALL	5220-0042

FOR SERVICE PARTS CALL OLIVER PRODUCTS @ 800-253-3893

Rev. 04/02/09



**797 Series of Slicers**

**BASE/CASTER& FEET ASSEMBLY**

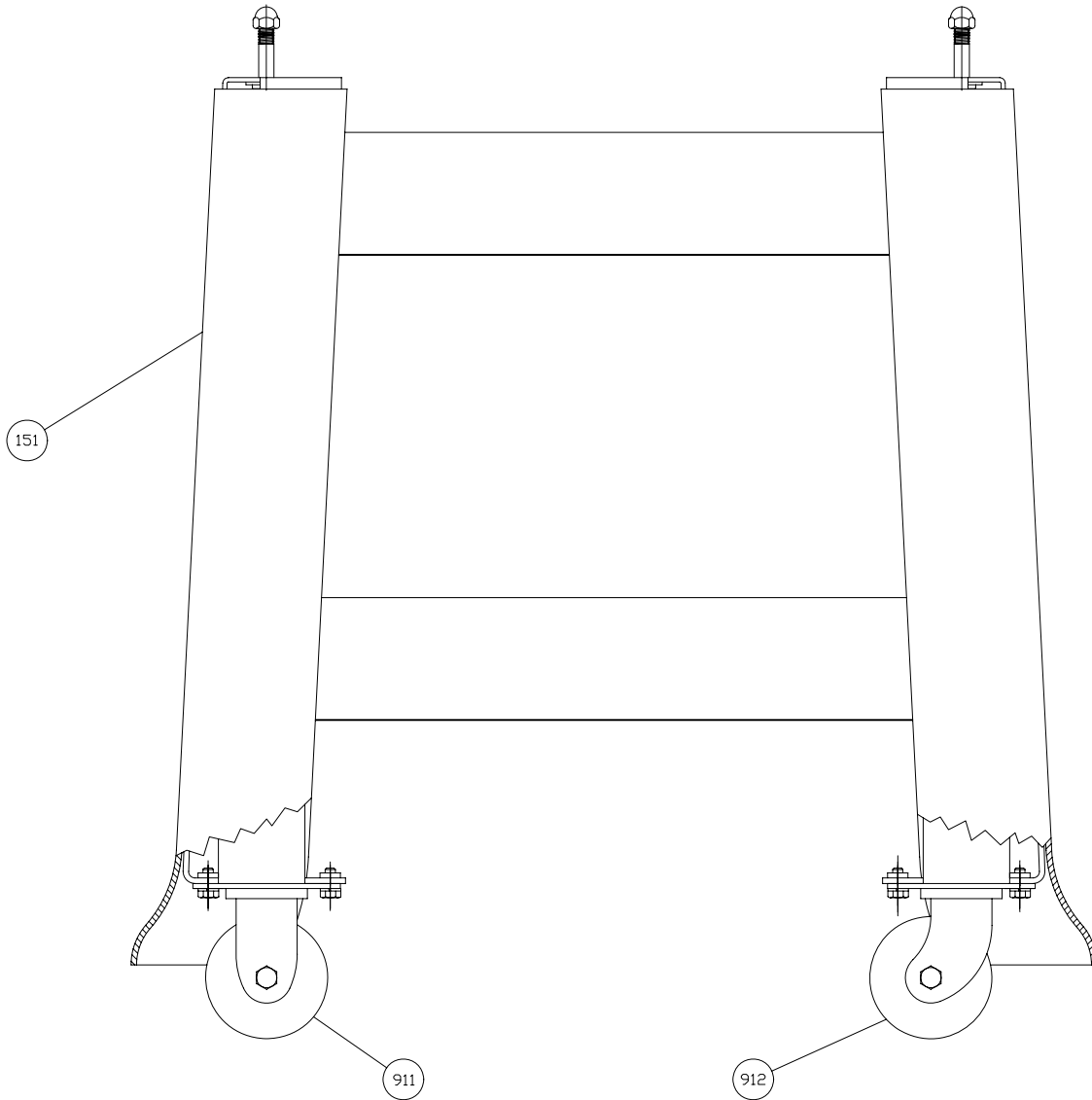



**797 Series of Slicers**

---

---

**BASE/CASTER PARTS LIST**

<b>ITEM NO</b>	<b>PART DESCRIPTION</b>	<b>PART NUMBER</b>
151	BASE-16" CASTER	0797-3068
152*	FOOT-RUBBER (UNITS W/O BASE)	0797-3257
911	CASTER-3" RIGID	5902-2363
912	CASTER-3" SWIVEL	5902-2364

\* Not Shown on Drawing

FOR SERVICE PARTS CALL OLIVER PRODUCTS @ 800-253-3893





### 797 Series of Slicers

## SLICE PARTS/HOLDDOWN

### ASSEMBLY

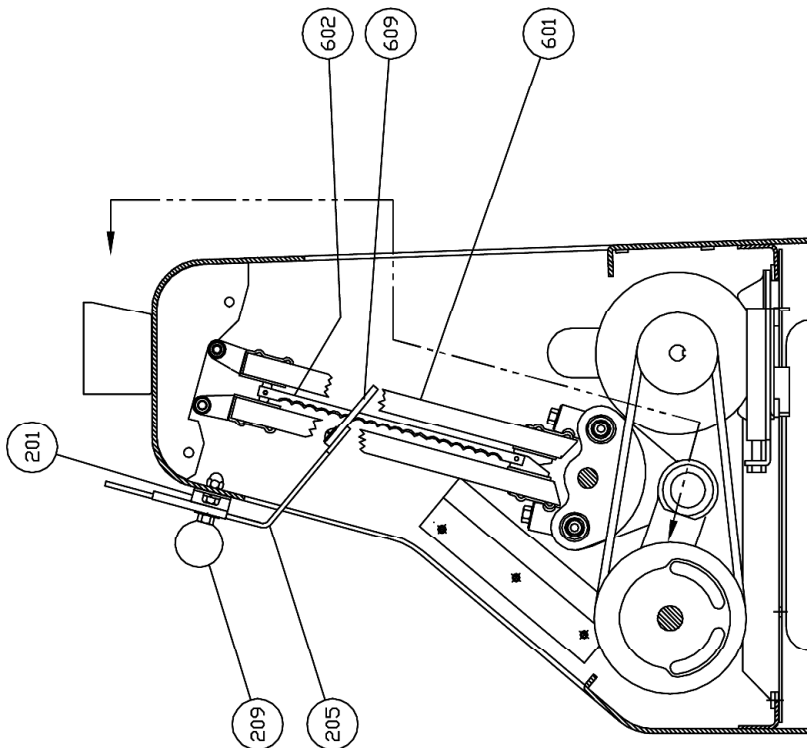
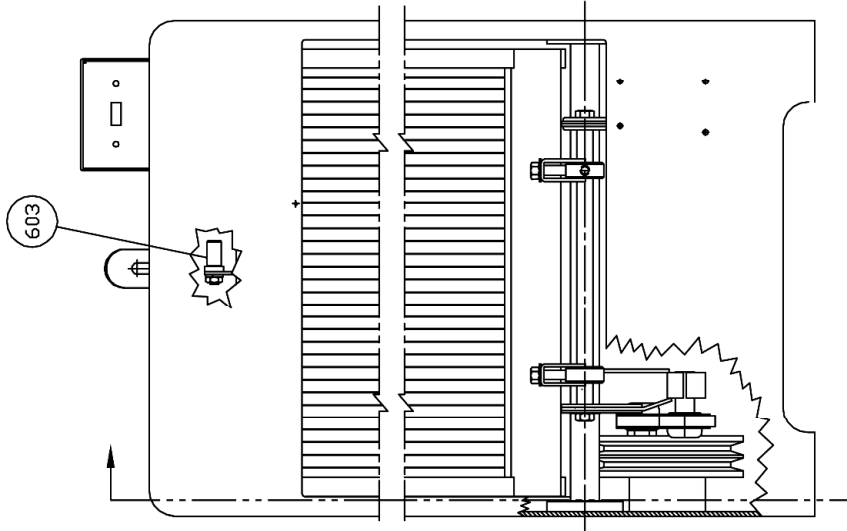



---

---

### 797 Series of Slicers

---

---

#### SLICE PARTS/HOLDDOWN PARTS LIST

<u>ITEM NO</u>	<u>PART DESCRIPTION</u>	<u>PART NUMBER</u>
201	BRACKET-HOLDDOWN	0797-3012
205	HOLDDOWN	0797-0358-201
209	KNOB	5911-7001
601*	FRAME-BLADE	0797-0300-5XX
602	KNIFE-TYPE A	0797-0029-1
603	PIN-BLADE FRAME	0797-0059-2
609*	GUIDE-KNIFE	0797-0092-0XX
612**	TOOL-BLADE CHANGING	0797-0183

\* Specify Slice Thickness

\*\* Not Shown on Drawing

FOR SERVICE PARTS CALL OLIVER PRODUCTS @ 800-253-3893

Rev. 4/29/13



### 797 Series of Slicers

## 32 & 48 INCH GRAVITY INFED CHUTE ASSEMBLY

### GRAVITY CHUTE

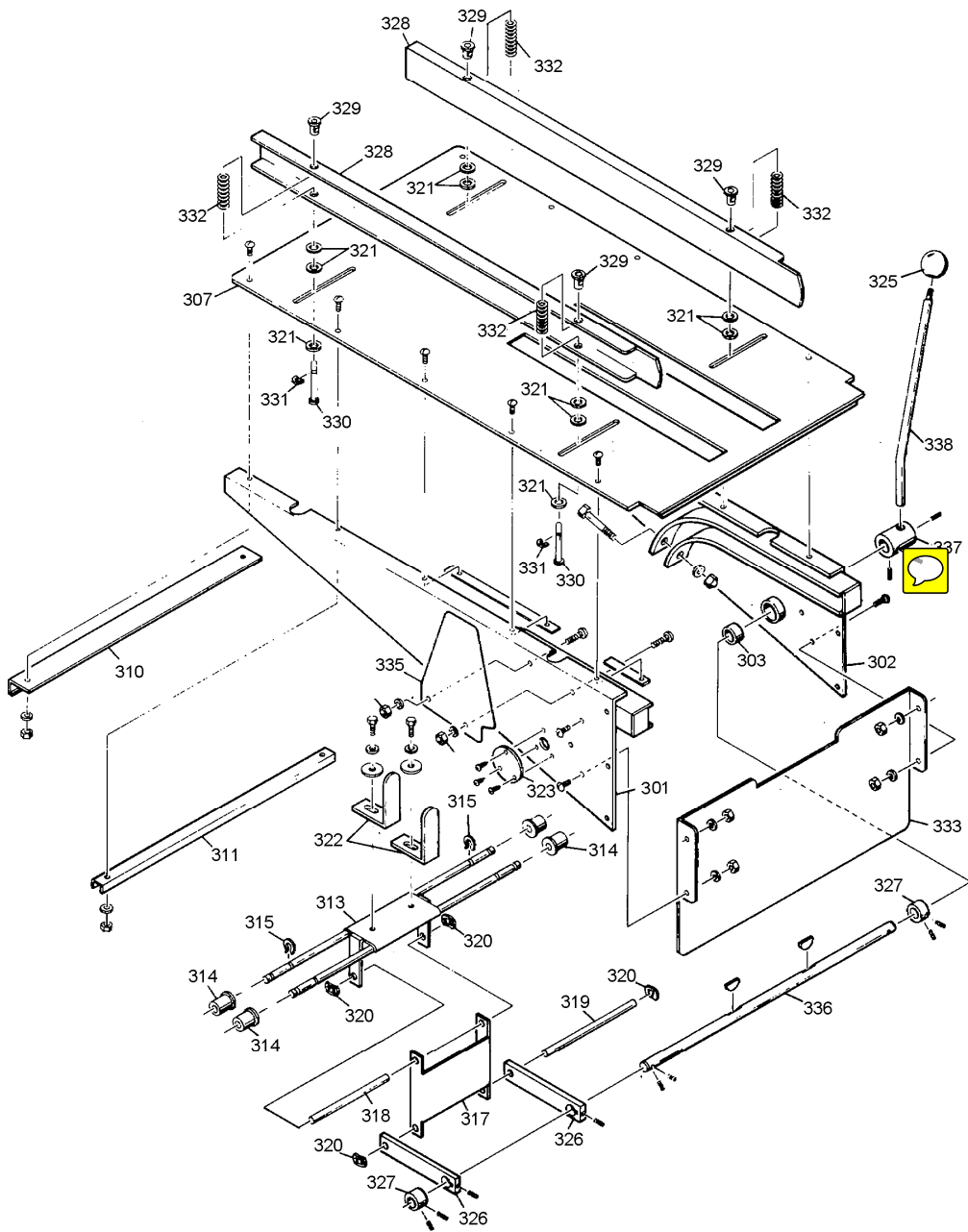

REV. 11/7/05



### 797 Series of Slicers

## 32 & 48 INCH GRAVITY INFEED CHUTE PARTS LIST

ITEM NO	PART DESCRIPTION	PART NUMBER
301	BRACE-RH 32" CHUTE	0797-2086-0011
301	BRACE-RH 48" CHUTE	0797-2088-0011
302	BRACE-LH 32" CHUTE	0797-2086-0012
302	BRACE-LH 48" CHUTE	0797-2088-0012
303	BEARING-BRONZE	5254-0300
307	TOP-32" GRAVITY CHUTE	0797-3004-001
307	TOP-48" GRAVITY CHUTE	0797-3008-007
310	BRACE-CHUTE TOP	0797-0237-1
311	BRACE-CHUTE END	0797-0377
313	CARRIAGE-PUSHER	0797-3063
314	WHEEL-CARRIAGE	5504-1700
315	RING-RETAINING	5840-1125
317	LINK	0797-3062
318	SHAFT-SHORT	4565-0508-0058
319	SHAFT- LONG	4565-0508-0063
320	CLIP-PUSH-ON	5831-8225
321	WASHER-NYLON	5851-8120
322	FINGER-PUSHER	0797-2077
323	CAP-CHUTE BRACE	0797-2080
325	KNOB	5911-7002
326	BAR-PUSHER	0797-3064
327	COLLAR-3/4" SET	5806-7012
328	GUIDE-32" SIDE	0797-3005-002
328	GUIDE-48" SIDE	0797-3010-001
329	BUSHING-SNAP	5765-1058
330	PIN-SIDE GUIDE	0797-3011-002
331	WASHER-HORSESHOE	0793-0084
332	SPRING-COMPRESSION	7012-3102
333	GUARD-CHUTE	0797-0915-002
335	GUARD-CHUTE CROTCH	0797-0947
336	SHAFT-PUSHER CROSS	0797-2076-002
337	HUB-PUSHER LEVER	0797-3070-001
338	LEVER-PUSHER	0711-0024

FOR SERVICE PARTS CALL OLIVER PRODUCTS @ 800-253-3893

REV.11/7/05



### 797 Series of Slicers

## CHUTE GUARD ASSEMBLY

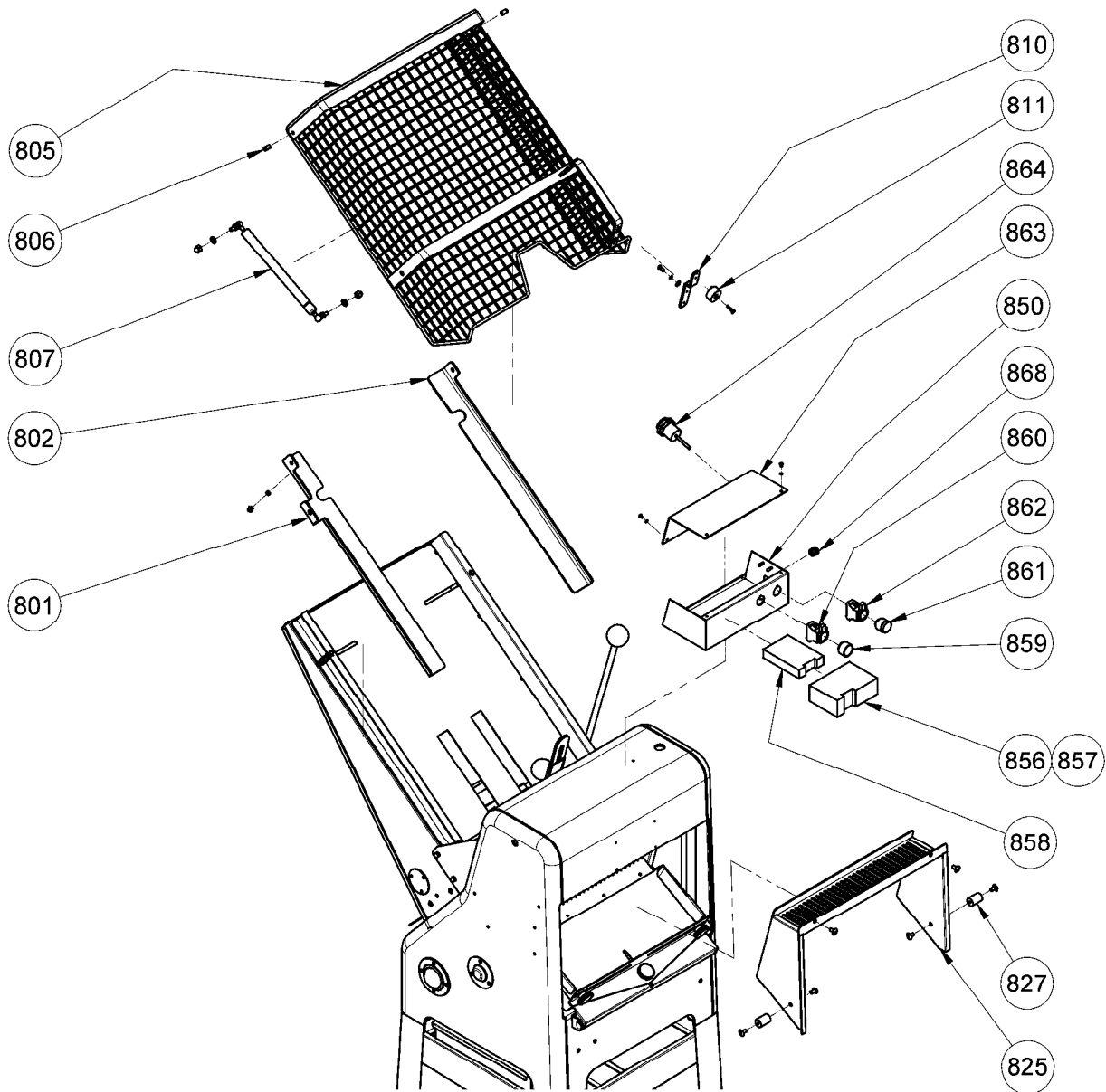

## CHUTE GUARD PARTS LIST



### 797 Series of Slicers

<b>ITEM NO</b>	<b>PART DESCRIPTION</b>	<b>PART NUMBER</b>
801	Bracket-RH 32" Mounting	0797-3444
802	Bracket-LH 32" Mounting	0797-3445
805	Guard-Wire Form	5501-4600
806	Stud-STST Pivot	0777-0067-001
807	Spring-Gas	6084-8707
810	Bracket-Magnet Mounting	0797-3446
811	Actuator-Safety Coded Magnet	5757-9397
825	Cover-Outfeed	0797-3449
827	Spacer-Threaded	0797-3450
850	Enclosure-Electrical	0797-3447
856	Contacto-3 pole, 600v, 12A	5749-8268
857	Relay-Overload 7-10 Amp (115V units)	5750-1281
858	Control-Safety	5712-5200
859	Operator-Green Push Button	5708-7900
860	Base-Mounting Block N.O. Contact	5708-7930
861	Operator-Red Extended Push Button	5708-7908
862	Base-Mounting Block N.C. Contact	5708-7931
863	Cover-Electrical Enclosure	0797-3448
864	Switch-Safety Coded Magnet	5757-9396
867*	Cord-Power (115V units)	0797-3451
868	Bushing-Strain Relief	5765-1076

\* Not Shown on Drawing

FOR SERVICE PARTS CALL OLIVER PRODUCTS @ 800-253-3893



### 797 Series of Slicers

## CHUTE GUARD WIRING DIAGRAM

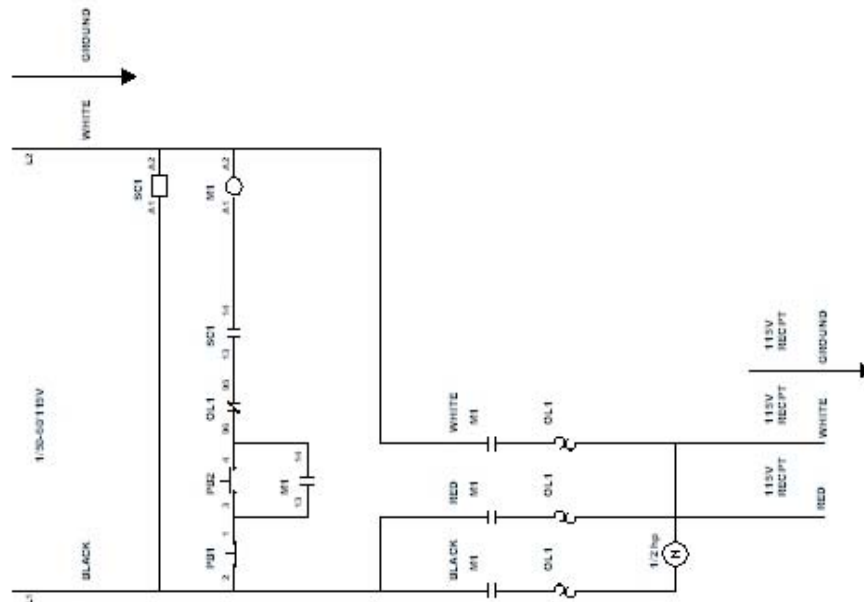
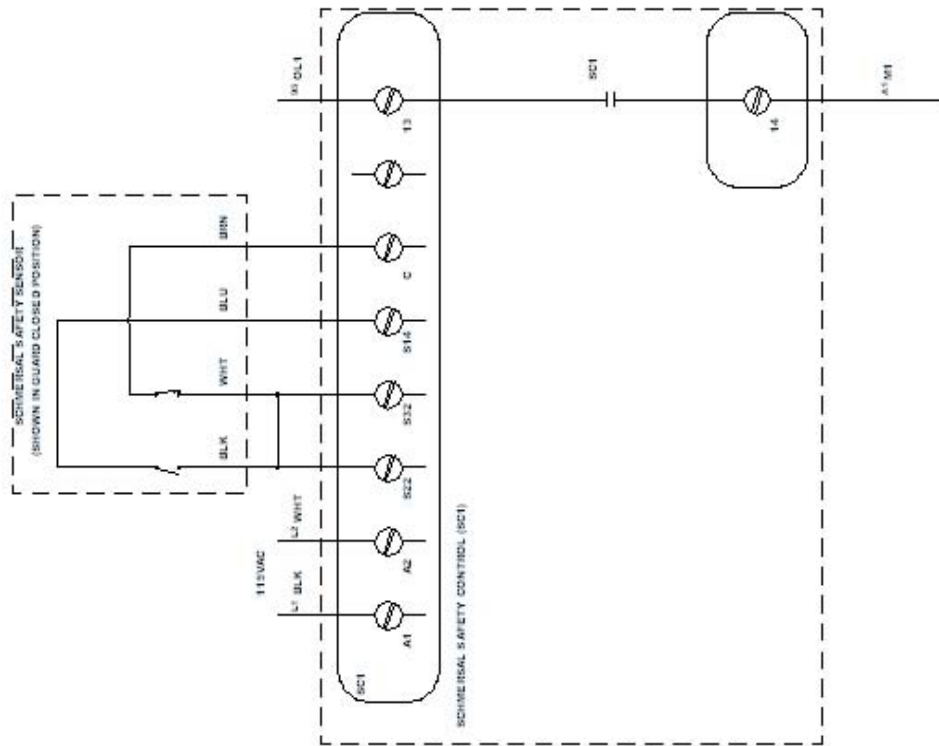

THIS PAGE WAS INTENTIONALLY  
LEFT BLANK.





### 797 Series of Slicers

## 48 INCH POWERBELT INFEEED ASSEMBLY

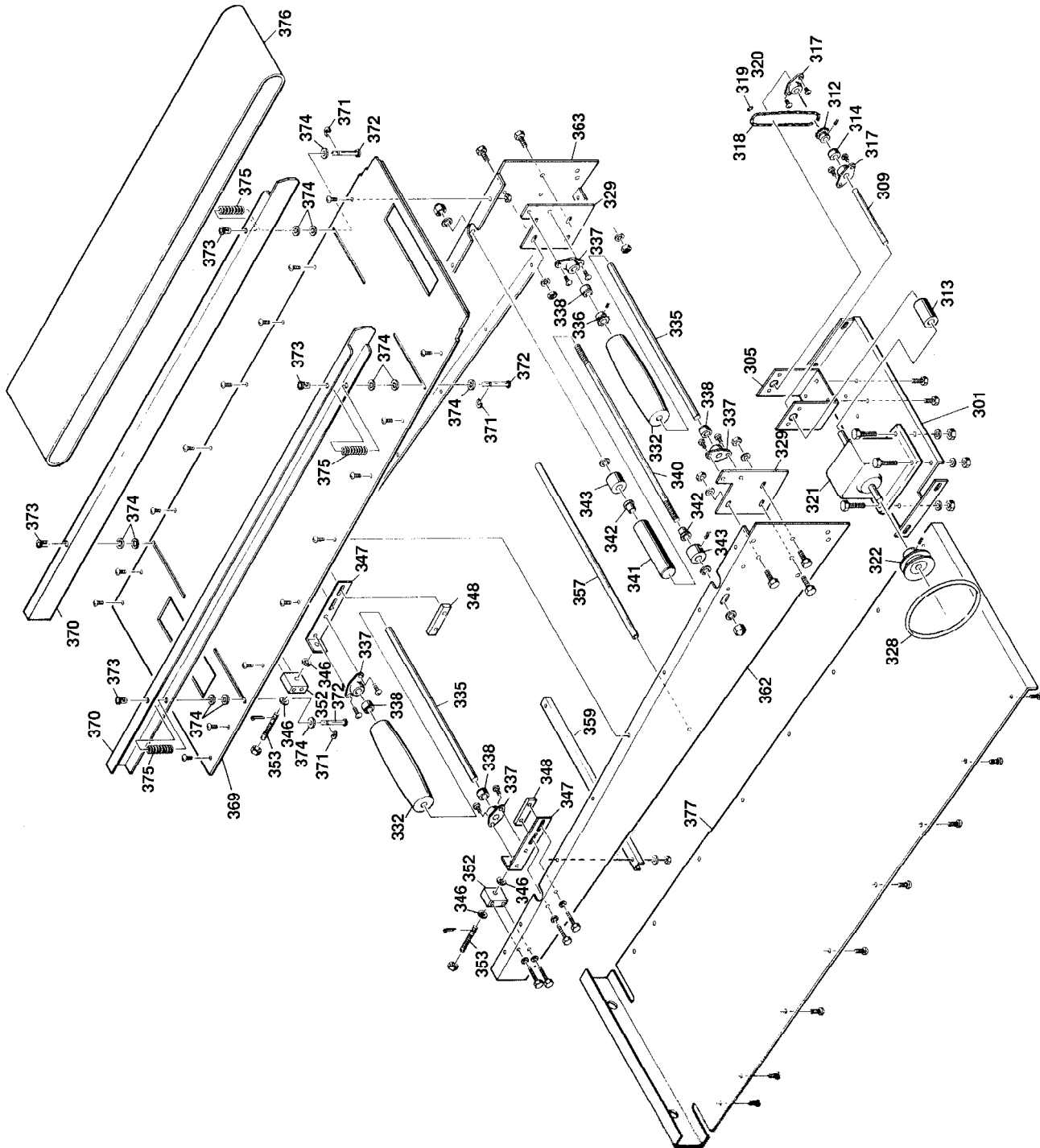



## 797 Series of Slicers

### 48 INCH POWERBELT INFEED PARTS LIST

ITEM NO	PART DESCRIPTION	PART NUMBER
301	CHANNEL-REDUCER	0797-3044-1
305	CHANNEL-SHAFT	0797-3027
309	SHAFT-DRIVE 1/2 DIA. X 5-5/8	0797-3375
312	SPROCKET-35B10 1/2" FB	5616-6041
313	COUPLING-FLEX JAW	5604-6956
314	COLLAR-1/2" SET	5806-7008
317	BEARING-1/2" FLANGE	5251-8045
318	CHAIN-INFEED DR. 12" (32P)	0797-3397
319	LINK-SPRING CLIP	5604-0100
320	LINK-OFFSET	5604-0104
321	UNIT-GEAR	5607-3238
322	SHEAVE-4L, 2.75 PD, 1/2 FB	0797-3460
328	BELT-ORANGE URETHANE	0797-3045
329	PLATE-BEARING	0797-3037
332	PULLEY-CONVEYOR	0797-3402
335	SHAFT-PULLEY	0797-3373
336	SPROCKET-35B10 5/8" FB	4618-3510-2001
337	BEARING-5/8" FLANGE	5251-8046
338	COLLAR-5/8" SET	5806-7010
340	STUD-DOUBLE END	4625-1212-1166
341	ROLL	0883-0227-033
342	BEARING-ROLL END 3/8 BORE	5252-3030
343	COLLAR-3/8" SET	5806-7006
346	WASHER-FLAT (SPECIAL)	5251-8140
347	ANGLE-BEARING	0797-3036
348	NUT-BAR	4460-1008-2012
352	BLOCK-ADJUSTING	0797-3034
353	BOLT-ADJUSTING	0797-3035
357	ROD-BRACE	0797-0261
359	BRACE	0797-0377
362	BRACE-CHUTE RH	0797-3009-0011
363	BRACE-CHUTE LH	0797-3009-0012
369	CHUTE-TOP	0797-3008-003
370	GUIDE-SIDE 48"	0797-3010-001
371	WASHER-BRASS HORSESHOE	0793-0084
372	PIN-SIDE GUIDE	0797-3011-002
373	BUSHING-SNAP	5765-1058
374	WASHER-NYLON FLAT	5851-8120
375	SPRING-COMPRESSION	7012-3102
376	BELT-CONVEYOR	5600-9468
377	PAN-BOTTOM	0797-3026
378*	WEIGHT-COUNTER	0797-3080-001
379*	TOOL-KNIFE (POWERBELT)	0797-0183-004

Rev. 3-20-08

\* Not Shown on Drawing

FOR SERVICE PARTS CALL OLIVER PRODUCTS @ 800-253-3893



**797 Series of Slicers**

**DRIVEN PULLEY ASSEMBLY**

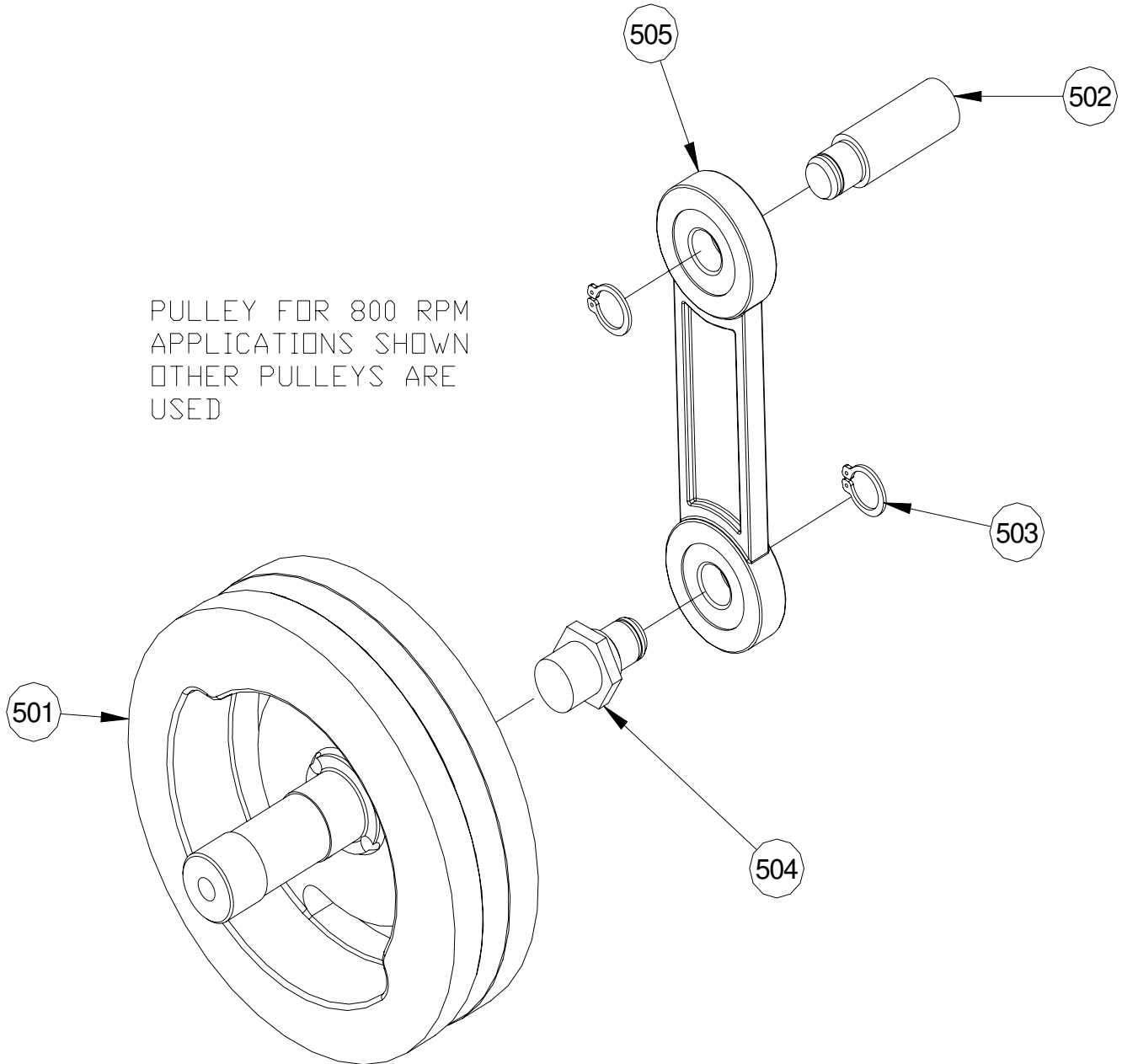

REV. 2/9/04



Oliver Packaging & Equipment Company  
3236 WISON DR NW WALKER MI. 49534

(800) 253-3893  
www.oliverquality.com

---

---

### 797 Series of Slicers

---

---

#### DRIVEN PULLEY PARTS LIST

<u>ITEM NO</u>	<u>PART DESCRIPTION</u>	<u>PART NUMBER</u>
501	PULLEY (32" CHUTES)	0730-0005
501	PULLEY (48" CHUTES)	0797-3370
502	STUD-SWING	0797-0057-219
503	RING-RETAINING	5840-2825
504	STUD	0797-0058-019
505	ROD-CONNECTING	0797-0071-4

FOR SERVICE PARTS CALL OLIVER PRODUCTS @ 800-253-3893  
REV. 2/12/09



### 797 Series of Slicers

#### STANDARD OUTFEED ASSEMBLY

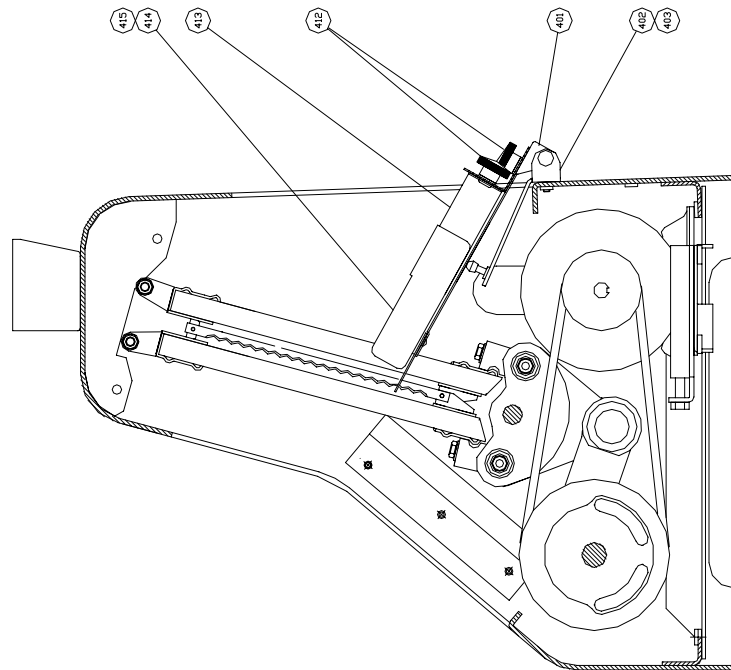
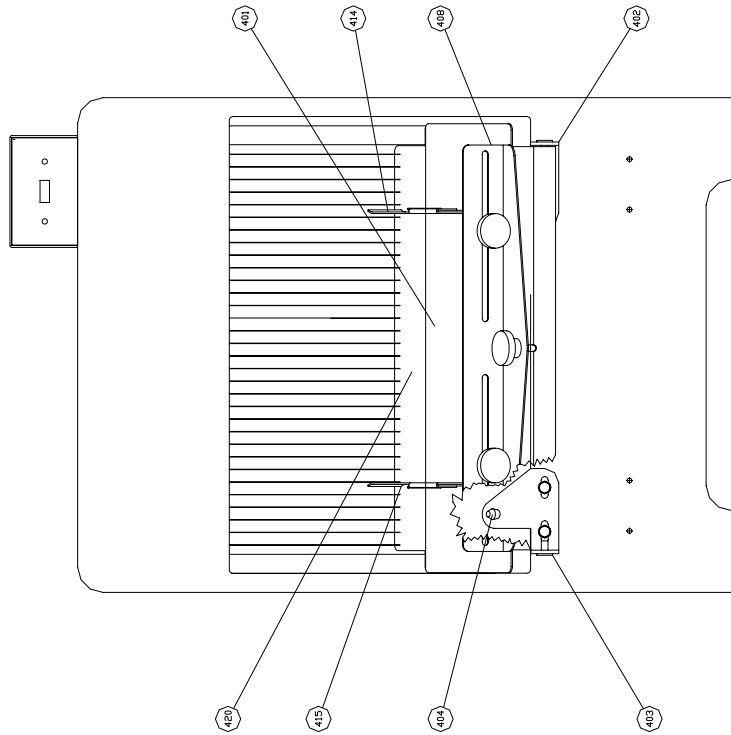



---

---

### 797 Series of Slicers

---

---

#### STANDARD OUTFEED PARTS LIST

<b>ITEM NO</b>	<b>PART DESCRIPTION</b>	<b>PART NUMBER</b>
401	TABLE-STANDARD OUTFEED	0797-0143-1
402	BRACKET- RH OUTFEED TABLE	0797-3013-0001
403	BRACKET- LH OUTFEED TABLE	0797-3013-0002
404	CAP-NEOPRENE	5106-8920
408	STOP-BREAD	0797-0141
412	KNOB	5911-7000
413	GUIDE-BREAD	0797-0284
414	EXTENSION-RH GUIDE	0797-0285-0001
415	EXTENSION-LH GUIDE	0797-0285-0002
420*	LIP-TABLE	0797-3001-0XX

\* Specify Slice Thickness

FOR SERVICE PARTS CALL OLIVER PRODUCTS @ 800-253-3893



797 Series of Slicers

BAGGER OUTFEED ASSEMBLY

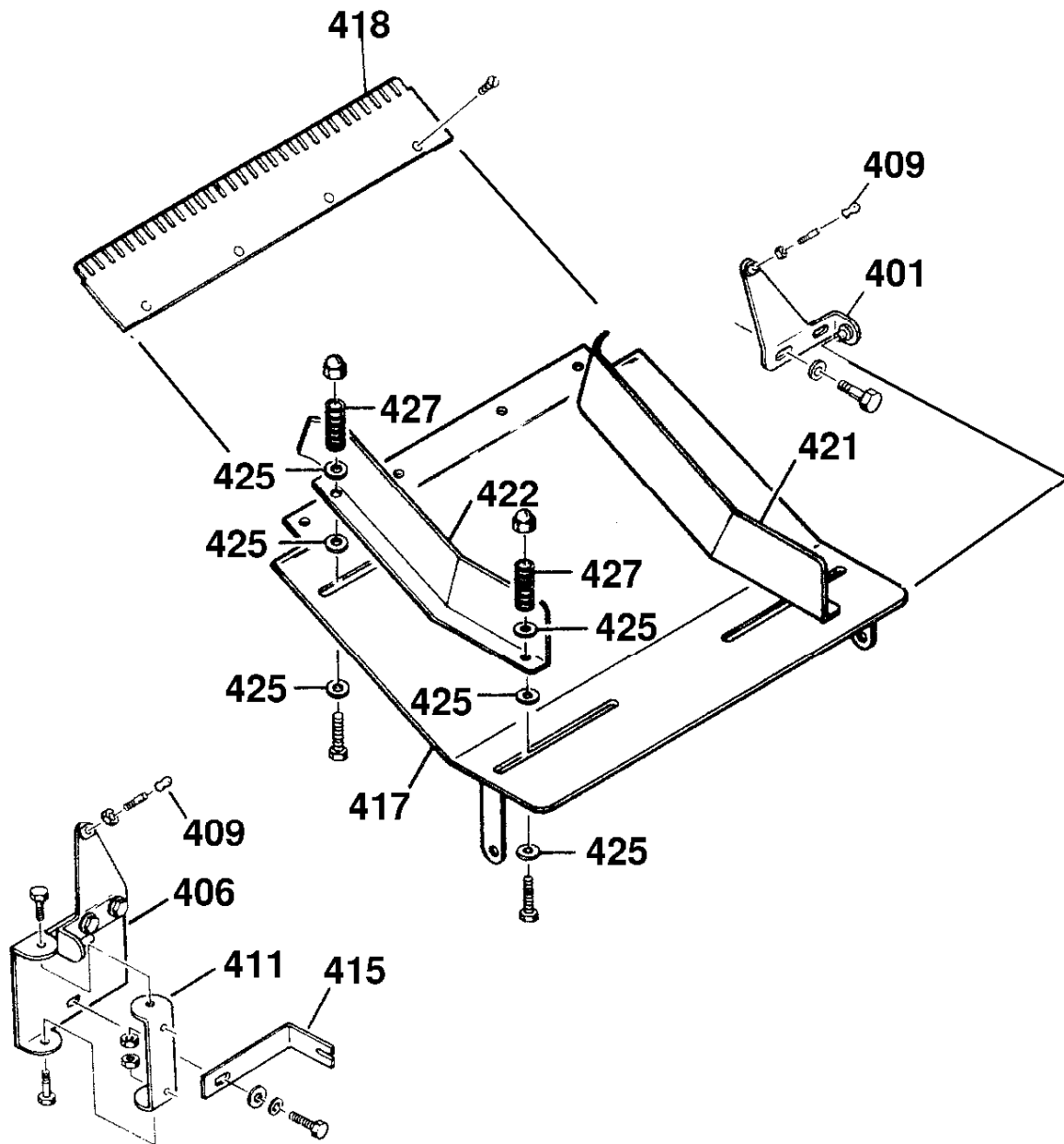



---

---

### 797 Series of Slicers

---

---

#### BAGGER OUTFEED PARTS LIST

<u>ITEM NO</u>	<u>PART DESCRIPTION</u>	<u>PART NUMBER</u>
401	BRACKET	0797-3013-0001
406	BRACKET-PIVOT RH	1179-0010-0001
409	CAP-NEOPRENE	5106-8920
411	BRACKET-CASE MOUNTING	1179-0011
415	BRACKET-CASE	1179-0012
417	TABLE-OUTFEED	1179-0008
418*	LIP-TABLE	0797-3001-0XX
421	GUIDE-SIDE RH	1179-0009-0001
422	GUIDE-SIDE LH	1179-0009-0002
425	WASHER-NYLON	5851-8120
427	SPRING-COMPRESSION	7013-2100
428**	WEIGHT-COUNTER	0797-3080-001

\* Specify Slice Thickness

\*\* Not Shown on Drawing

FOR SERVICE PARTS CALL OLIVER PRODUCTS @ 800-253-3893





797 Series of Slicers

CURVED OUTFEED ASSEMBLY

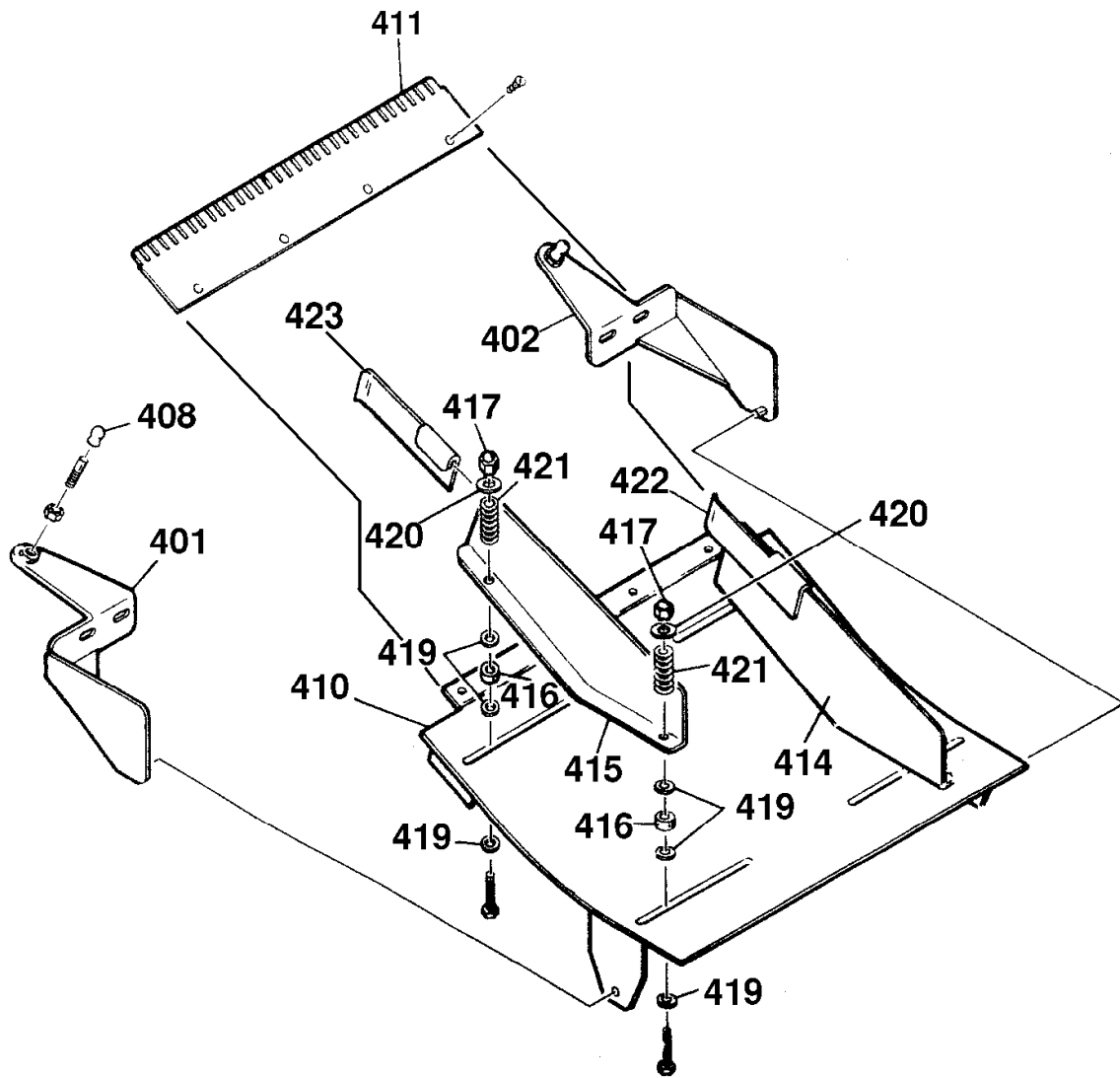



---

---

### 797 Series of Slicers

---

---

#### CURVED OUTFEED PARTS LIST

<u>ITEM NO</u>	<u>PART DESCRIPTION</u>	<u>PART NUMBER</u>
401	BRACKET-HINGE RH	0797-3040-1001
402	BRACKET-HINGE LH	0797-3040-1002
408	CAP-NEOPRENE	5106-8920
410	TABLE-CURVED	0797-3029-1
411*	LIP-TABLE	0797-3001-0XX
414	GUIDE-SIDE RH	0797-3030-1001
415	GUIDE-SIDE LH	0797-3030-1002
416	COLLAR-FILLING	4130-0708-0003
417	NUT-ACORN 1/4-20	5832-0590
419	WASHER-NYLON	5851-8120
420	WASHER-STAINLESS STEEL	5851-9304
421	SPRING-COMPRESSION	7013-2100
422	EXTENSION-RH	0797-0285-0001
423	EXTENSION-LH	0797-0285-0002

\* Specify Slice Thickness

FOR SERVICE PARTS CALL OLIVER PRODUCTS @ 800-253-3893



### 797 Series of Slicers

## SINGLE PHASE ELECTRICAL

### Wiring Diagram (Single Phase)

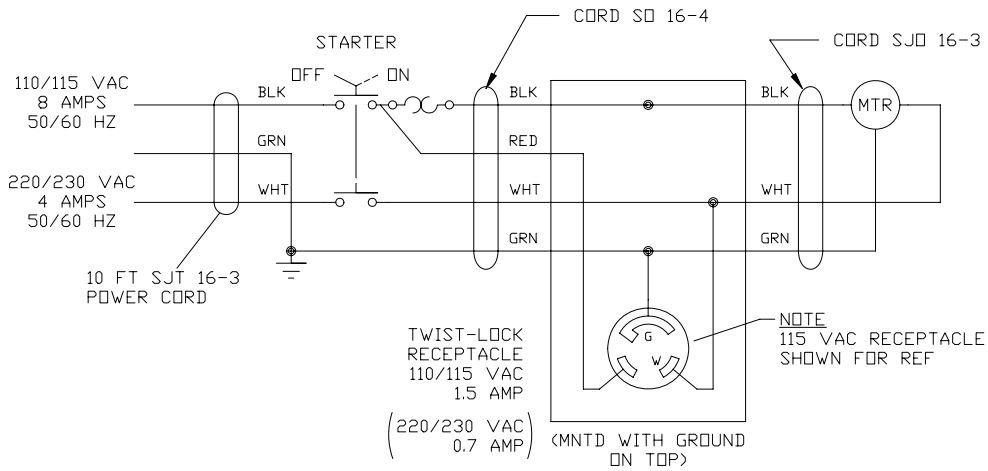

### Single Phase Electrical Assembly Drawing

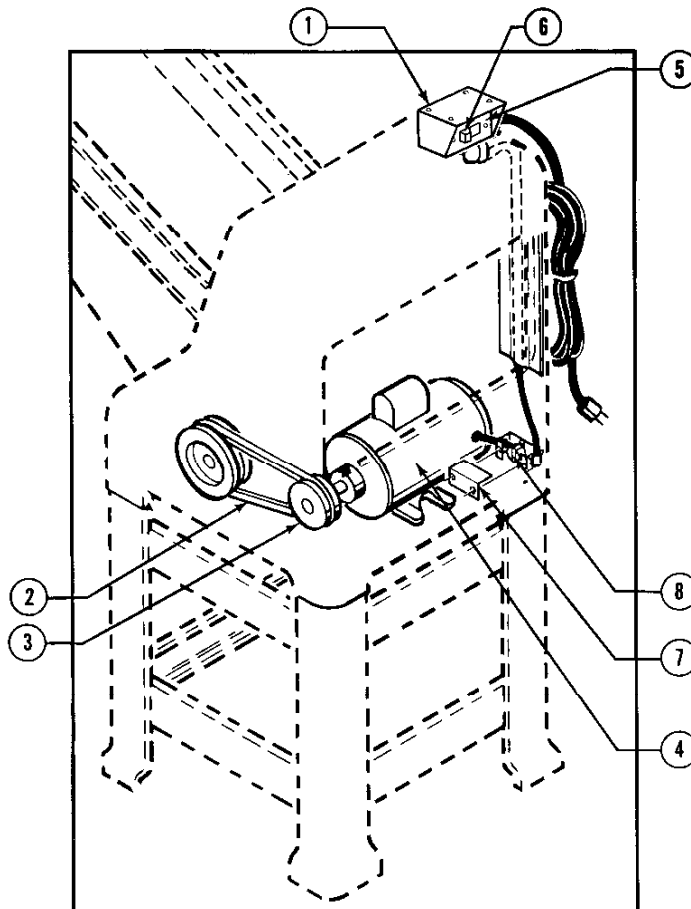



### 797 Series of Slicers

#### Parts List 1/2 HP, 115 VAC, 60 Hert , 1 Phase

<u>ITEM NO</u>	<u>PART DESCRIPTION</u>	<u>PART NUMBER</u>
1	ENCLOSURE-SWITCH	0797-3393-001
2	BELT-V (4L36-1/2)	5601-1966
3	PULLEY-MOTOR (32" CHUTES)	4575-7103-2001
3	PULLEY-MOTOR (48" CHUTES)	4575-7103-2004
4	MOTOR	6301-3609
5	COVER-SWITCH ENCLOSURE	0797-3394-001
6	SWITCH-STARTER	5709-1125
7	COVER-RECEPTACLE ENCLOSURE	0797-3385
8	RECEPTACLE-110/115 VAC	5769-0524

#### Parts List 1/2 HP, 230 VAC, 60 Hert , 1 Phase

<u>ITEM NO</u>	<u>PART DESCRIPTION</u>	<u>PART NUMBER</u>
1	ENCLOSURE-SWITCH	0797-3393-001
2	BELT-V (4L36-1/2)	5601-1966
3	PULLEY-MOTOR (32" CHUTES)	4575-7103-2001
3	PULLEY-MOTOR (48" CHUTES)	4575-7103-2004
4	MOTOR	6301-3609
5	COVER-SWITCH ENCLOSURE	0797-3394-001
6	SWITCH-STARTER	5709-1125
7	COVER-RECEPTACLE ENCLOSURE	0797-3385
8	RECEPTACLE-220/230 VAC	5769-0523

#### Parts List 1/2 HP, 110 VAC, 50 Hert , 1 Phase

<u>ITEM NO</u>	<u>PART DESCRIPTION</u>	<u>PART NUMBER</u>
1	ENCLOSURE-SWITCH	0797-3393-001
2	BELT-V (4L36-1/2) (32" CHUTES)	5601-1966
2	BELT-V (XDV48-380) (48" CHUTES)	5601-1969
3	PULLEY-MOTOR (32" CHUTES)	4575-7104-2002
3	PULLEY-MOTOR (48" CHUTES)	4575-7104-2005
4	MOTOR	6301-3940
5	COVER-SWITCH ENCLOSURE	0797-3394-001
6	SWITCH-STARTER	5709-1125
7	COVER-RECEPTACLE ENCLOSURE	0797-3385
8	RECEPTACLE-110/115 VAC	5769-0524

#### Parts List 1/2 HP, 220 VAC, 50 Hert , 1 Phase

<u>ITEM NO</u>	<u>PART DESCRIPTION</u>	<u>PART NUMBER</u>
1	ENCLOSURE-SWITCH	0797-3393-001
2	BELT-V (4L36-1/2) (32" CHUTES)	5601-1966
2	BELT-V (XDV48-380) (48" CHUTES)	5601-1969
3	PULLEY-MOTOR (32" CHUTES)	4575-7104-2002
3	PULLEY-MOTOR (48" CHUTES)	4575-7104-2005
4	MOTOR	6301-3940
5	COVER-SWITCH ENCLOSURE	0797-3394-001
6	SWITCH-STARTER	5709-1125
7	COVER-RECEPTACLE ENCLOSURE	0797-3385
8	RECEPTACLE-220/230 VAC	5769-0523

For Service Parts Call Oliver Products @ 800-253-3893

Rev 10-13-04



### 797 Series of Slicers

## THREE PHASE ELECTRICAL

### Wiring Diagram (Three Phase)

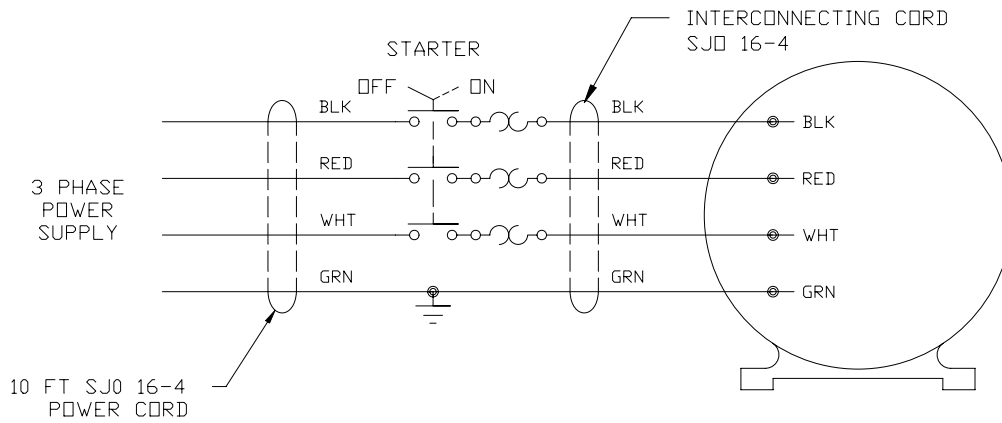

### Three Phase Electrical Assembly Drawing

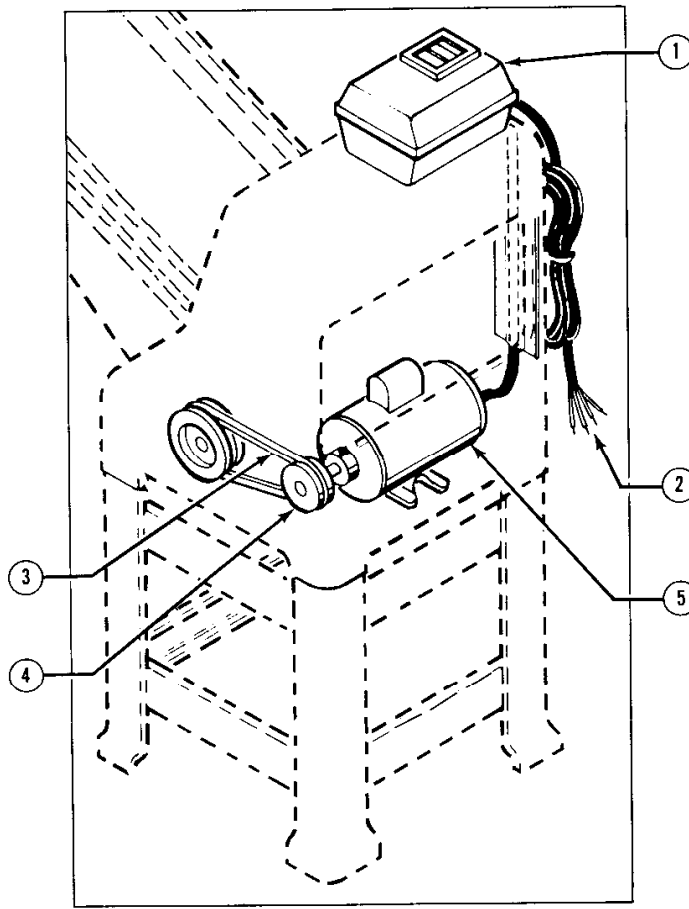



### 797 Series of Slicers

#### Parts List 1/2 HP, 208 VAC, 60 Hertz, 3 Phase

<b>ITEM NO</b>	<b>PART DESCRIPTION</b>	<b>PART NUMBER</b>
1	STARTER	5709-3034
2	CORD-POWER	0797-3426
3	BELT-V (4L36-1/2)	5601-1966
4	PULLEY-MOTOR (32" CHUTES)	4575-7103-2001
4	PULLEY-MOTOR (48" CHUTES)	4575-7103-2004
5	MOTOR	6301-3811

#### Parts List 1/2 HP, 230/460 VAC, 60 Hertz, 3 Phase

<b>ITEM NO</b>	<b>PART DESCRIPTION</b>	<b>PART NUMBER</b>
1	STARTER	5709-3034
2	CORD-POWER	0797-3426
3	BELT-V (4L36-1/2)	5601-1966
4	PULLEY-MOTOR (32" CHUTES)	4575-7103-2001
4	PULLEY-MOTOR (48" CHUTES)	4575-7103-2004
5	MOTOR	6301-3800

#### Parts List 1/2 HP, 220 VAC, 50 Hertz, 3 Phase

<b>ITEM NO</b>	<b>PART DESCRIPTION</b>	<b>PART NUMBER</b>
1	STARTER	5709-3034
2	CORD-POWER	0797-3426
3	BELT-V (4L36-1/2) (32" CHUTES)	5601-1966
3	BELT-V (XDV48-380) (48" CHUTES)	5601-1969
4	PULLEY-MOTOR (32" CHUTES)	4575-7104-2002
4	PULLEY-MOTOR (48" CHUTES)	4575-7104-2005
5	MOTOR	6301-3811

#### Parts List 1/2 HP, 380 VAC, 50 Hertz, 3 Phase

<b>ITEM NO</b>	<b>PART DESCRIPTION</b>	<b>PART NUMBER</b>
1	STARTER	5709-3034
2	CORD-POWER	0797-3426
3	BELT-V (4L36-1/2) (32" CHUTES)	5601-1966
3	BELT-V (XDV48-380) (48" CHUTES)	5601-1969
4	PULLEY-MOTOR (32" CHUTES)	4575-7104-2002
4	PULLEY-MOTOR (48" CHUTES)	4575-7104-2005
5	MOTOR	6301-3975

For Service Parts Call Oliver Products @ 800-253-3893

Rev 10-13-04



Oliver Packaging & Equipment Company  
3236 WISON DR NW WALKER MI. 49534

(800) 253-3893  
www.oliverquality.com

## WARRANTY

### PARTS

Oliver Packaging & Equipment Company warrants that if any part of the equipment (other than a part not manufactured by Oliver) proves to be defective (as defined below) within two years after shipment, and if Buyer returns the defective part to Oliver Packaging & Equipment within two years, Freight Prepaid to Oliver Packaging & Equipment's plant in Grand Rapids, MI, then Oliver Packaging & Equipment, shall, at Oliver Packaging & Equipment's option, either repair or replace the defective part, at Oliver Packaging & Equipment's expense.

### LABOR

Oliver Packaging & Equipment further warrants that equipment properly installed in accordance with our special instructions, which proves to be defective in material or workmanship under normal use within two (2) years from installation or two (2) years and three (3) months from actual shipment date, whichever date comes first, will be repaired by Oliver Packaging & Equipment or an Oliver Packaging & Equipment Authorized Service Dealer, in accordance with Oliver Packaging & Equipment's published Service Schedule.

For purposes of this warranty, a defective part or defective equipment is a part or equipment which is found by Oliver Packaging & Equipment to have been defective in materials workmanship, if the defect materially impairs the value of the equipment to Buyer. Oliver Packaging & Equipment has no obligation as to parts or components not manufactured by Oliver Packaging & Equipment, but Oliver Packaging & Equipment assigns to Buyer any warranties made to Oliver Packaging & Equipment by the manufacturer thereof.

This warranty **does not** apply to:

1. Damage caused by shipping or accident.
2. Damage resulting from improper installation or alteration.
3. Equipment misused, abused, altered, not maintained on a regular basis, operated carelessly, or used in abnormal conditions.
4. Equipment used in conjunction with products of other manufacturers unless such use is approved by Oliver Packaging & Equipment in writing.
5. Periodic maintenance of equipment, including but not limited to lubrication, replacement of wear items, and other adjustments required due to installation, set up, or normal wear.
6. Losses or damage resulting from malfunction.

The foregoing warranty is in lieu of all other warranties expressed or implied AND OLIVER PACKAGING & EQUIPMENT MAKES NO WARRANTY OF MERCHANTABILITY OR FITNESS FOR PURPOSE REGARDING THE EQUIPMENT COVERED BY THIS WARRANTY. Oliver Packaging & Equipment neither assumes nor authorizes any person to assume for it any other obligations or liability in connection with said equipment. OLIVER PACKAGING & EQUIPMENT SHALL NOT BE LIABLE FOR LOSS OF TIME, INCONVENIENCE, COMMERCIAL LOSS, INCIDENTAL OR CONSEQUENTIAL DAMAGES.



Oliver Packaging & Equipment Company  
3236 WISON DR NW WALKER MI. 49534

(800) 253-3893  
[www.oliverquality.com](http://www.oliverquality.com)

## WARRANTY PROCEDURE

1. If a problem should occur, either the dealer or the end user must contact the Parts and Service Department and explain the problem.
2. The Parts and Service Manager will determine if the warranty will apply to this particular problem.
3. If the Parts and Service Manager approves, a Work Authorization Number will be generated, and the appropriate service agency will perform the service.
4. The service dealer will then complete an invoice and send it to the Parts and Service Department at Oliver Packaging & Equipment Company.
5. The Parts and Service Manager of Oliver Packaging and Equipment Company will review the invoice and returned parts, if applicable, and approve for payment.





Oliver Packaging & Equipment Company  
3236 WISON DR NW WALKER MI. 49534

(800) 253-3893  
[www.oliverquality.com](http://www.oliverquality.com)

## RETURNED PARTS POLICY

This policy applies to all parts returned to the factory whether for warranted credit, replacement, repair or re-stocking.

Oliver Packaging and Equipment Company requires that the customer obtain a Return Material Authorization (RMA) number before returning any part. This number should appear on the shipping label and inside the shipping carton as well. All parts are to be returned prepaid. Following this procedure will insure prompt handling of all returned parts.

To obtain an RMA number contact the Repair Parts Department toll free at (800) 253-3893.

Parts returned for re-stocking are subject to a **RE-STOCKING CHARGE**.

Thank you for your cooperation,

Repair Parts Manager  
Oliver Packaging and Equipment Company